

FASCINATION FOR PRECISION

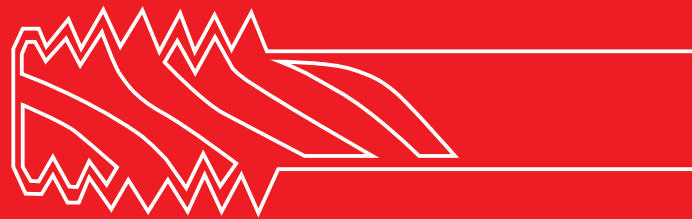

# WERKZEUGE FÜR DIE METALLZERSPANUNG

## GESAMTKATALOG

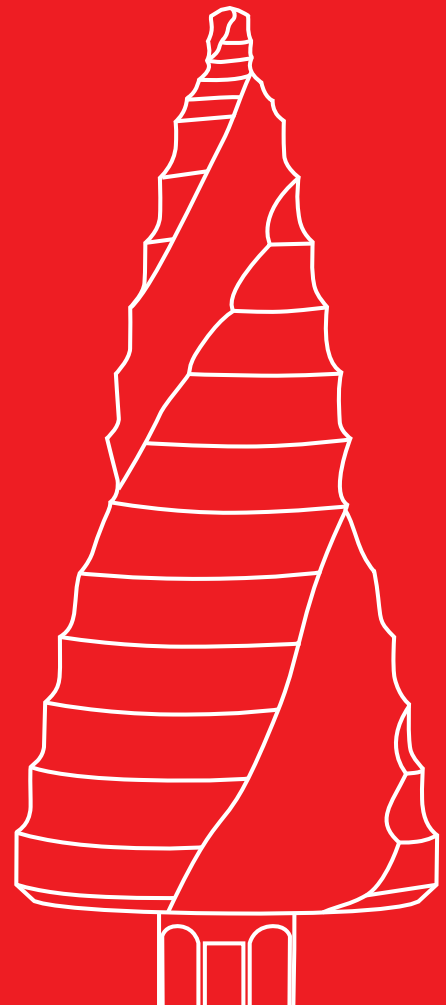

Ein Handwerker will keinen 8er-Bohrer.  
Er will ein präzises 8er-Loch im Werkstück.

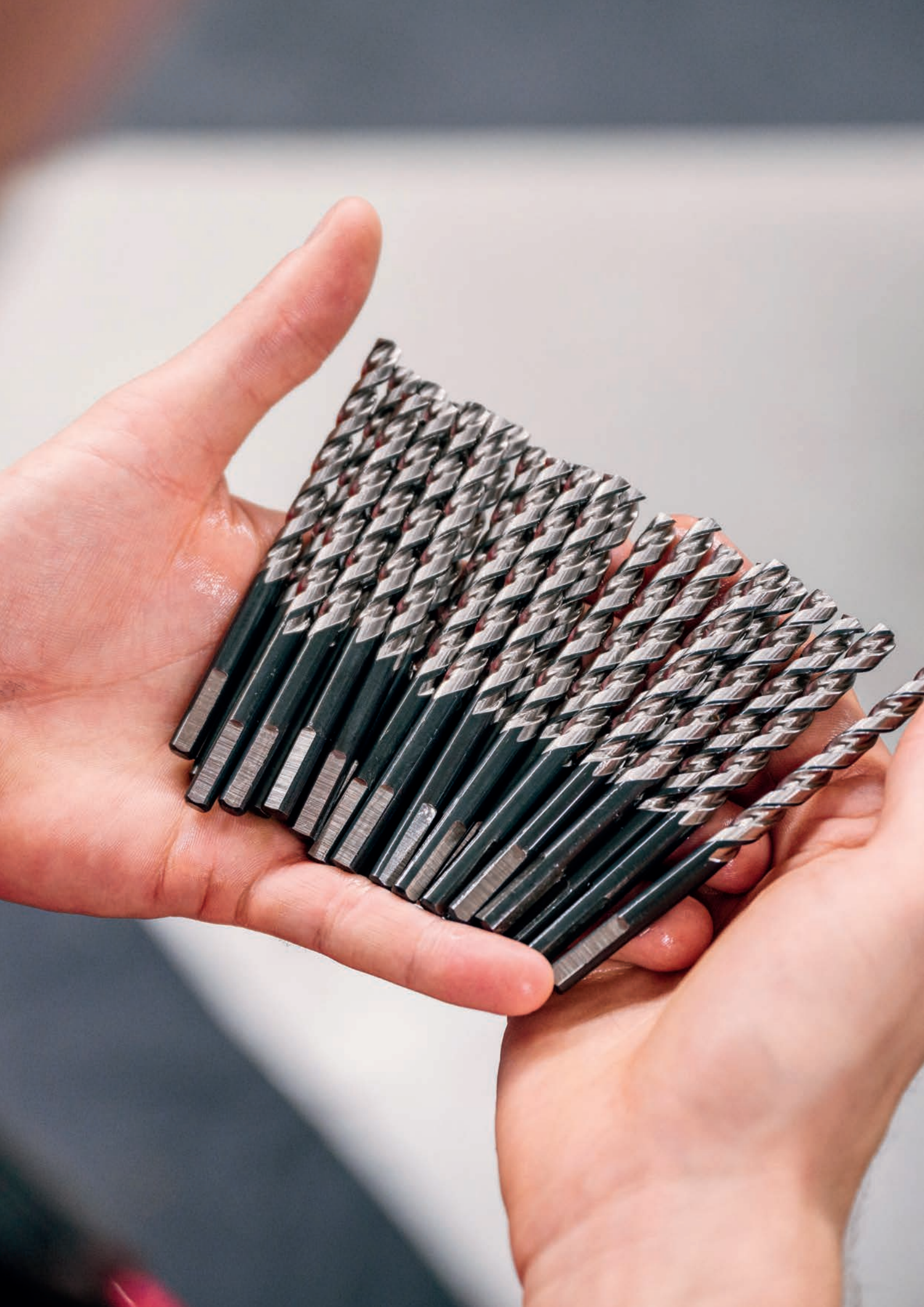

## RUKO Präzisionswerkzeuge

In jedem Einzelnen steckt unsere Leidenschaft und die unbändige Liebe zum Detail

Arbeitsprozesse ändern sich, die Zeitfenster für die Realisierung von Projekten werden immer straffer, die Erwartungshaltungen von Auftragsgeber\*innen an ein perfektes und fehlerfreies Ergebnis wachsen stetig an.

Den steigenden Herausforderungen in Handwerk und Industrie mit den richtigen Werkzeugen zu begegnen, bildet die Grundlage für jede RUKO-Entwicklung.

Denn unabhängig, ob bei der Arbeit mit handgeführten Werkzeugen oder in der Serienfertigung auf stationären Anlagen – jeder Bohrer, jeder Senker, jedes Gewindewerkzeug und auch jeder Frässtift, steht am Ende der Prozesskette und trägt ganz entscheidend zur Qualität des erzielten Arbeitsergebnisses bei.

Dabei fokussieren wir uns auf die ausschließliche Verwendung von Schnellarbeitsstahl (HSS) oder noch höheren Legierungen. Dazu fertigen wir auf hochmodernen Produktionsanlagen und bewerten nach hohen Qualitätsstandards. Und dazu setzen wir auf eine Mannschaft, die mit Akribie und schwäbischem Tüftlertum daran arbeitet, Werkzeuge in puncto Verschleißfestigkeit, Arbeitseffizienz und Präzision im manuellen und stationären Einsatz zu verbessern.

Eben diese Leidenschaft und die Liebe zum Detail sind dabei zugleich Wurzel und Antrieb für jede Innovation und die konsequente Optimierung auch bereits bestehender Produkte.

Für Werkzeuge, die perfekt auf das Handwerk und die Industrie zugeschnitten sind.

Und für Werkzeuge, die den Namen RUKO Präzisionswerkzeuge – Made in Germany tragen.



# ULTIMATECUT®

Oder wie man perfekte Werkzeuge perfektioniert



Erfunden, um deine Arbeit jeden Tag noch ein Stück besser zu machen, steht die Premiumlinie ULTIMATECUT als Garant für perfekte Arbeitsergebnisse in der Industrie und im professionellen Handwerk.

Spiralbohrer, Stufenbohrer, Kegelsenker – mit innovativer FLOWSTEP® Spitze, speziell entwickelter FLOWSTEP® Schneidgeometrie und beim Senken mit vier statt drei Schneiden.

Für mehr Effizienz und weniger Nacharbeit. Für mehr Tempo mit bis zu dreifach schnelleren Arbeitsergebnissen. Mit hoher Verschleißfestigkeit für deutlich mehr Einsätze der Werkzeuge.



# Tuning für's Bohren, Senken und Schneiden

Die RUKO-eigene Beschichtung

Best of the best: Unsere RUnATEC-Beschichtung überzeugt mit absoluten Spitzenwerten: In den Bereichen Reibungsverlust, Nanohärte, der Möglichkeit bis maximal 1.100 Grad Celcius mit extrem hohen Schnittgeschwindigkeiten zu arbeiten und einer bis zu 16-fach höheren Standzeit gegenüber unbeschichteten Spanwerkzeugen.

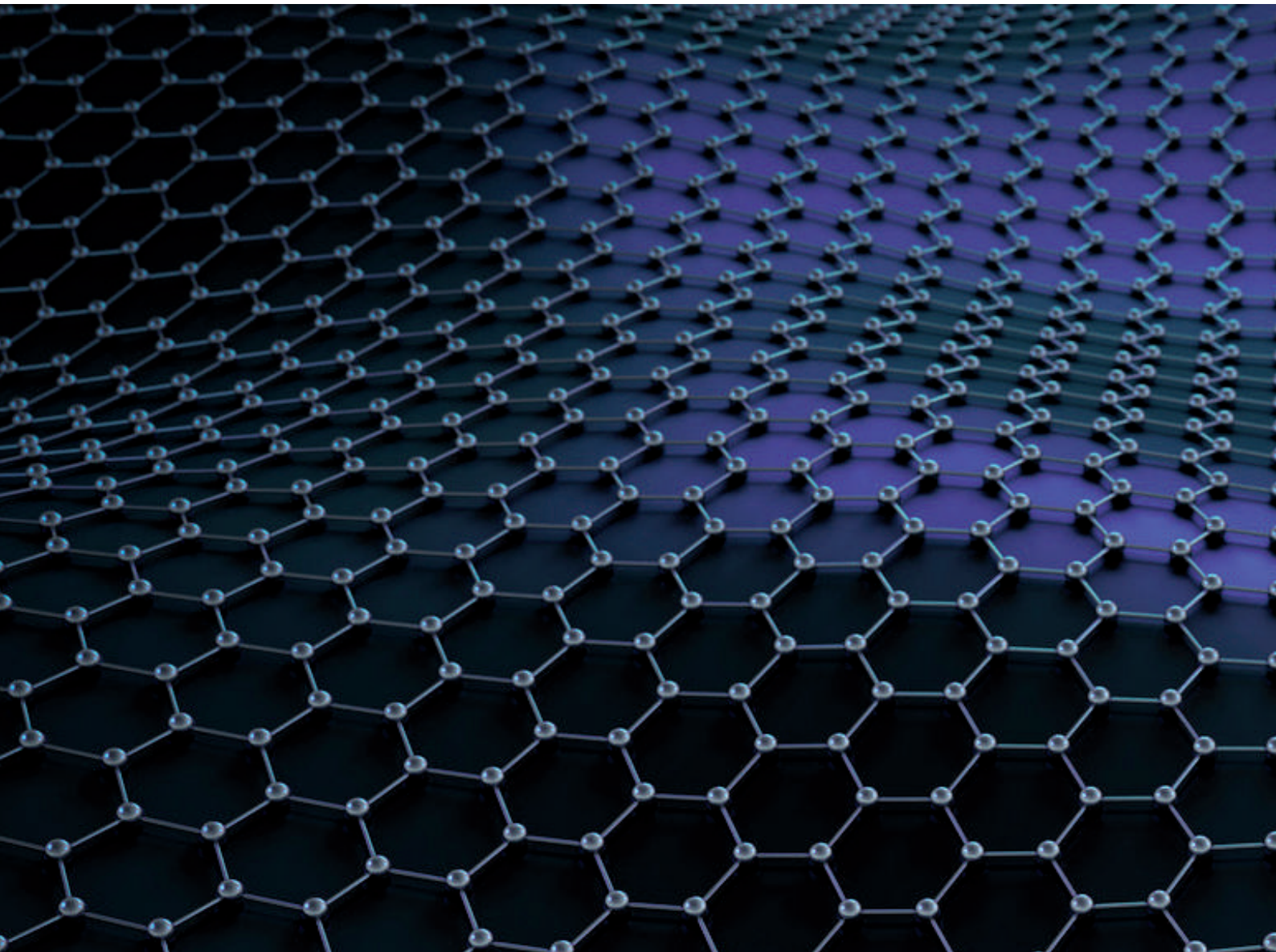



Beschichtete Werkzeuge sind zwar auf den ersten Blick zu erkennen, aber dennoch weit mehr als optische Kosmetik.

Denn analog zum Rennsport geht es bei Beschichtungen darum, jedes Werkzeug hinsichtlich Leistung und Haltbarkeit auf ein Optimum zu maximieren.

Dazu gehört beispielsweise eine deutliche Reduzierung der Reibung, die Möglichkeit mit höheren Schnittgeschwindigkeiten schnellere und gleichzeitig präzisere Bohrungen durchzuführen, aber auch durch eine gleichmäßige Abnutzung eine konstant hohe Bearbeitungsqualität über die gesamte Standzeit des Werkzeuges zu garantieren.

Ein weiterer Vorteil: Die Werkzeuge müssen seltener ausgetauscht werden, was zu weniger Ausfallzeiten und einer effizienteren Bearbeitung führt.

Und um beim Rennsport zu bleiben – in der perfekten Kombination aus Schnittgeschwindigkeit, Nanohärte und extrem geringen Reibungsverlusten, nimmt dabei die eigen entwickelte RUKO nano Technology, kurz RUnaTEC, die uneingeschränkte Poleposition unter allen angebotenen Beschichtungen ein.

In Summe eine clevere Investition, die sich durch die Einsparungen bei Werkzeugkosten, kürzeren Bearbeitungszeiten und reduzierten Ausfallzeiten in echtem Renntempo amortisiert.

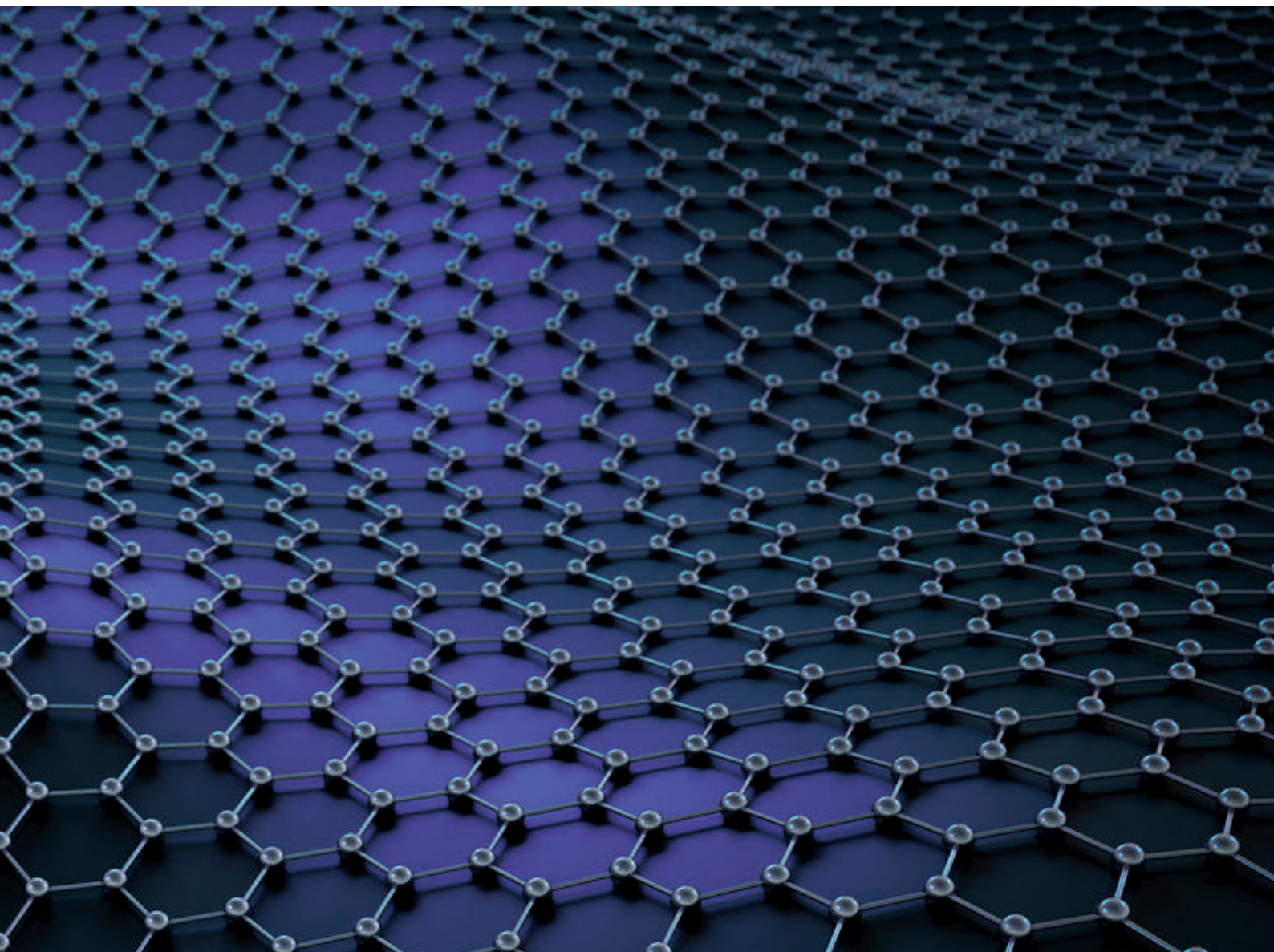

# RUKO Anwendungsfarbleitsystem

Der Ursprung des RUKO Anwendungsfarbleitsystems basiert auf den drei großen Anwendungsfeldern Metall, Beton und Holz. Aus der detaillierten Gliederung des Anwendungsfeldes Metall in Baustahl, Innox und hochfesten Stahl, ergeben sich zusammen mit Beton und Holz die fünf primären Anwendungsgruppen des RUKO Anwendungsfarbleitsystems.

## METALL

## BETON

## HOLZ

 <b>STEEL</b>	 <b>INOX</b>	 <b>HIGH STRENGTH STEEL</b>	 <b>CONCRETE</b>	 <b>WOOD</b>
<b>Baustahl</b> <b>&lt; 900 N/mm<sup>2</sup></b>	<b>Inox</b> <b>&lt; 1.100 N/mm<sup>2</sup></b>	<b>Hochfester Stahl</b> <b>&lt; 1.300 N/mm<sup>2</sup></b>	<b>z. B. Stein,</b> <b>Beton</b>	<b>z. B. Weichholz,</b> <b>Spanplatten</b>

## Stahleigenschaften

<b>HSS</b>	Schnellarbeitsstahl für Bohrungen in gut bearbeitbare Materialien mit einer Festigkeit von bis zu 900 N/mm <sup>2</sup> .	<b>HSSE Co8</b>	Schnellarbeitsstahl mit 8 % Kobaltanteil. Sehr hohe Zähigkeit und ausgezeichnete Wärmebeständigkeit, für Bohrungen in hochfeste Werkstoffe bis zu 1.100 N/mm <sup>2</sup> .
<b>HSSE Co5</b>	Schnellarbeitsstahl mit 5 % Kobaltanteil. Hohe Zähigkeit und Wärmebeständigkeit, für Bohrungen in schwer bearbeitbare Materialien mit einer Festigkeit von bis zu 1.100 N/mm <sup>2</sup> .	<b>TC HM</b>	Vollhartmetall ist besonders gut geeignet für Bohrarbeiten in hochfesten Stahl bei hohen Schnittgeschwindigkeiten.

Bezeichnung	Norm			Chemische Zusammensetzung in %								Härte
	DIN	EN	AISI	C	Cr	Mo	V	TiC TAC	W	Wc	Co	
HSS	1.3343	ENHS 6-5-2	M 2	0,90	4,1	5,0	1,8	–	6,4	–	–	780 – 800 HV10
HSSE-Co5	1.3243	ENHS 6-5-2-5	M 35	0,92	4,1	5,0	1,9	–	6,4	–	4,8	820 – 920 HV10
HSSE-Co8	1.3247	ENHS 2-10-1-8	M 42	1,10	3,9	9,2	1,2	–	1,4	–	7,8	850 – 960 HV10
TC	K20	–	–	–	–	–	–	2,0	–	92,0	6,0	15.500 HV30

## Beschichtungen

<b>TiN</b>	Die Titan-Nitrit-Beschichtung ist eine universal einsetzbare Standardschicht. Sie bietet eine 300 bis 400 % höhere Standzeit im Vergleich zu unbeschichteten Werkzeugen. Kühlung ist empfehlenswert.	<b>AlTiN</b>	Die Aluminium-Titan-Nitrit-Beschichtung bietet eine sehr hohe Warmhärte- und Oxidationsbeständigkeit. Sehr gut geeignet zum Bohren von harten Werkstoffen ohne Kühlung.
<b>TiCN</b>	Die Titan-Carbon-Nitrit-Beschichtung bietet hohe Härte und zugleich gute Zähigkeit. Sie weist einen sehr niedrigen Reibungswert auf. Einsetzbar zum Bohren von hochfestem Stahl. Kühlung ist notwendig.	<b>RUna TEC</b>	Die RUKO-eigene RUnaTEC-Beschichtung bietet eine extrem hohe Verschleißfestigkeit und Warmhärte. Sie ist für Normal- und Hochleistungszerpannung geeignet. Das Ergebnis ist eine optimale, glatte Oberfläche sowie keinerlei Materialverschweißungen. Die RUnaTEC-Beschichtung kann auch zur Trockenbearbeitung eingesetzt werden.
<b>TiAlN</b>	Die Titan-Aluminium-Nitrit-Beschichtung bietet eine hohe Warmhärte- und Oxidationsbeständigkeit. Sie ist besonders geeignet zum Bohren von harten Werkstoffen ohne Kühlung.	<b>LONG LIFE</b>	Die mit Long Life gekennzeichneten Produkte verfügen aufgrund ihrer beschichteten Oberfläche über eine zusätzliche Verschleißfestigkeit und längere Standzeit.

Beschichtung	Farbe	Nanohärte bis [GPa]	Schichtdicke [µm]	Reibungskoeffizient	Max. Anwendungstemperatur [°C]
TiN	gold-gelb	24	1 – 7	0.55	600
TiCN	rot-kupfer	32	1 – 4	0.2	400
TiAlN	violett-schwarz	30	1 – 4	0.6	700
AlTiN	blau-schwarz	38	1 – 4	0.7	900
RUnaTEC	violett-blau	45	1 – 4	0.45	1.200

# Kapitelverzeichnis

	01 Spiralbohrer		Seiten 10 – 59
	02 Spezialbohrer		Seiten 60 – 65
	03 Bleeschälbohrer		Seiten 66 – 71
	04 Stufenbohrer		Seiten 72 – 95
	05 Senker		Seiten 96 – 125
	06 Gewindebohrwerkzeuge	Handgewindebohrer Maschinengewindebohrer	Seiten 126 – 147 Seiten 148 – 179
	07 Gewindereparaturwerkzeuge		Seiten 180 – 185
	08 Kernbohrtechnik	Kernbohrer Magnetbohrmaschinen	Seiten 186 – 205 Seiten 206 – 221
	09 Frässtifte		Seiten 222 – 241
	10 Lochsägen		Seiten 242 – 257
	11 Sägen		Seiten 258 – 287
	12 Entgrater		Seiten 288 – 295
	13 Schraublochstanzen		Seiten 296 – 301
	14 Kühl- und Schmierstoffe		Seiten 302 – 303
	15 Betonbohrer		Seiten 304 – 313

**01**



# SPIRALBOHRER

Übersicht der Symbole	14 – 15
Typen- und Anwendungsübersicht	18 – 21
ULTIMATECUT DIN 338 Typ FLOWSTEP®, HSSE-Co 5	22
ULTIMATECUT DIN 338 Typ FLOWSTEP®, HSS	23
ULTIMATECUT DIN 338 Typ FLOWSTEP® + Maschinengewindebohrer M DIN 371 / 376 Form B	24
ULTIMATECUT DIN 338 Typ FLOWSTEP® + Einschnittgewindebohrer M ≈ DIN 352 HSS	24
DIN 338 Typ VA, HSSE-Co 8 + TiAlN	26 – 28
DIN 338 Typ VA, HSSE-Co 5	30 – 32
DIN 338 Typ VA, HSSE-Co 5 – <i>Zollabmessungen</i>	33
DIN 338 Typ UNI, HSSE-Co 5	34
DIN 338 TL 3000, HSS + TiAlN	36 – 37
DIN 338 Typ N, HSS + TiN	38 – 41
DIN 338 Typ N, HSS – <i>Zollabmessungen</i>	42
DIN 338 Typ N, HSS TiN – <i>Zollabmessungen</i>	43
DIN 338 Typ N, HSS-G mit TiN-Spitzenbeschichtung	44
DIN 338 Typ N, HSS – <i>linksschneidend</i>	45
DIN 338 Typ N, HSS-R	46 – 48
DIN 338 Typ N, HSS-R + HSS VAP + HSSE-Co 5 mit abgesetztem Schaft	49
DIN 340 Typ N, HSS-G	50
DIN 1869 TL 3000, HSS – <i>extra lang</i>	51
DIN 345 Typ N, HSS + HSSE-Co 5	52 – 53
DIN 1897 Typ N, HSSE-Co 5 – <i>kurz</i>	54
DIN 1897 Typ N, HSS + TiN – <i>kurz</i>	55
Doppelendbohrer Typ KV, HSS	56
Zentrierbohrer DIN 333, HSS	56
Verwendung der Bohrer und Schneidbedingungen	57
Drehzahltable für Spiralbohrer	58 – 59



# ULTIMATECUT<sup>®</sup>

## Spiralbohrer mit FLOWSTEP<sup>®</sup> Spitze

Er lässt dich 5-mal mehr bohren.  
Er macht dich doppelt so schnell.  
Er spart dir Kraft.



### **RUKO** FLOWSTEP<sup>®</sup> Spitze

Punktgenaues Zentrieren = kein Verrutschen beim Ansetzen.  
Zeitersparnis durch schnelleres Anbohren = mehr Bohrlöcher in derselben Zeit.  
Kräftesparendes Bohren = mehr Löcher ohne Pause.



### **RUKO** 3-Flächenschaft

Kein Durchrutschen im Bohrfutter, dadurch optimale Kraftübertragung.

Kein Nachspannen mehr im Bohrfutter, dies ermöglicht einfaches und unkompliziertes Arbeiten.



### **RUKO** Schwarze Fase

Die schwarze Fase erhöht die Verschleißfestigkeit und reduziert gleichzeitig Kaltverschweißungen an den Nutenrändern.

# Übersicht der Symbole

## Bohrertypen

<b>N</b>	<b>Typ N</b> Spiralwinkel: 20 – 30° Nutprofil: normal Kern: normal Spitzenwinkel: 118 – 130°
<b>TL 3000</b>	<b>Typ TL 3000</b> Spiralwinkel: 40° Nutprofil: breit, mit gerundeten hinteren Kanten Kern: dick Spitzenwinkel: 130° Spitzenanschliff: Form C
<b>UTL 3000</b>	<b>Typ UTL 3000</b> Spiralwinkel: 40° Nutprofil: breit, mit gerundeten hinteren Kanten Kern: sehr dick Spitzenwinkel: 130° Spitzenanschliff: Form U
<b>UNI</b>	<b>Typ UNI</b> Spiralwinkel: 40° Nutprofil: breit, für bessere Spanabfuhr Kern: normal Spitzenwinkel: 135° Spitzenanschliff: Form C
<b>VA</b>	<b>Typ VA</b> Spiralwinkel: 36° Nutprofil: normal Kern: verdickt Spitzenwinkel: 130° Spitzenanschliff: Form C
<b>KV</b>	<b>Typ KV</b> Spiralwinkel: 25 – 30° Nutprofil: normal Kern: normal Spitzenwinkel: 130° Spitzenanschliff: Form C
<b>FT</b>	<b>Typ FLOWSTEP®</b> Spiralwinkel: 20 – 30° Nutprofil: normal Kern: normal Spitzenanschliff: Stufenformige Spitzenausführung FLOWSTEP® Spitze

## DIN-Normen

<b>DIN 333</b>	Zentrierbohrer 60° Form A und R
<b>DIN 345</b>	Spiralbohrer mit Morsekegelschaft
<b>DIN 338</b>	Kurze Spiralbohrer mit Zylinderschaft
<b>DIN 1869</b>	Überlange Spiralbohrer mit Zylinderschaft
<b>DIN 340</b>	Lange Spiralbohrer mit Zylinderschaft
<b>DIN 1897</b>	Extra kurze Spiralbohrer mit Zylinderschaft

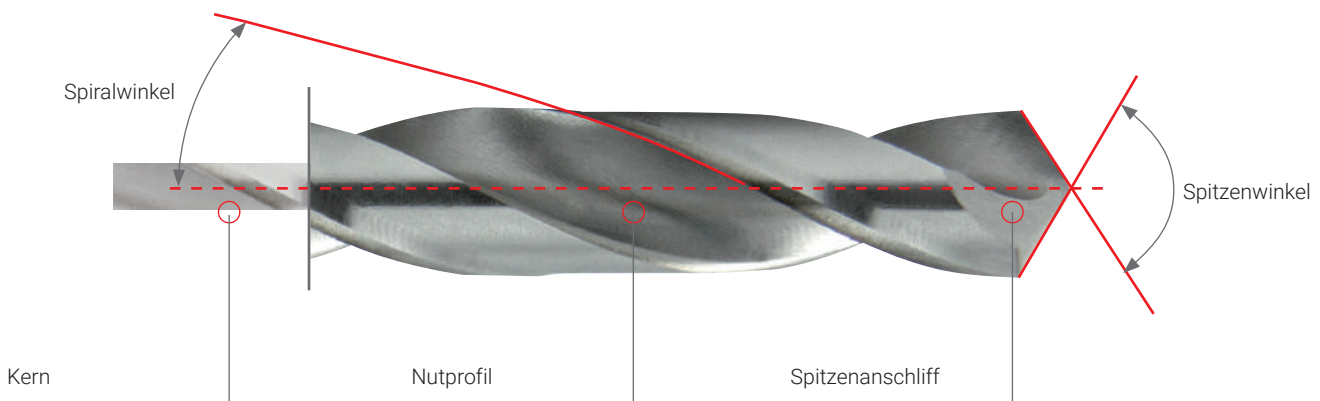



## Anschliffe und Ausspitzungen nach DIN 1412



### Form N: Kegelmantelschliff Normalschliff

Anwendung: Für alle üblichen Bohrarbeiten in Stahl, Buntmetallen und Kunststoffen. Die Spitzenwinkel richten sich nach der Zerspanbarkeit der Werkstoffe.

Vorteile: Kräftige Hauptschneiden, unempfindlich gegen Stoß und Seitenkräfte. Einfacher Anschlag von Hand möglich.

Nachteile: Breite Querschneide erfordert hohe Vorschubkraft.



### Form A: Ausgespitzte Querschneide

Anwendung: Für alle üblichen Bohrarbeiten bei Bohrern mit starkem Kern, bei großen Bohrerdurchmessern zum Bohren ins volle Material.

Vorteile: Gute Zentrierung beim Anbohren durch Verkürzung der Querschneidenlänge auf 1/10 des Bohrerdurchmessers und Verringerung der Vorschubkraft.

Nachteile: Zusätzliche Schleifarbeit.



### Form B: Ausgespitzte Querschneide mit korrigierter Hauptschneide

Anwendung: Bei Bohrern für Stähle mit hoher Festigkeit, für Manganstähle mit über 10 % Mn, für harte Federstähle und zum Aufbohren.

Vorteile: Unempfindlich gegen Stoß, einseitige Belastung und Seitenkräfte. Kein Einhaken bei dünnwandigen Werkstücken.

Nachteile: Hohe Vorschubkraft, Neigung zum Verlaufen, Mehraufwand beim Nachschleifen.



### Form C: Kreuzanschliff

Anwendung: Für Bohrungen in Grauguß, Temperguß und Schmiedestücke.

Vorteile: Schonung der Schneidenecken durch verlängerte Hauptschneiden, unempfindlich gegen Stoß, gute Wärmeableitung – dadurch verbesserte Standzeit.

Nachteile: Mehraufwand beim Nachschleifen.



### Form D: Anschlag für Grauguss

Anwendung: Bei Bohrern mit sehr starkem Kern für besonders zähe, harte Werkstoffe und bei Tieflochbohrern.

Vorteile: Gute Zentrierung, geringe Vorschubkraft. Durch Spanverteilung verbesserter Spantransport.

Nachteile: Einwandfreier Nachschliff nur maschinell möglich.



### Form E: Zentrumspitze

Anwendung: Zum Bohren von Blechen und weichen Werkstoffen, für Sacklöcher mit ebenem Grund.

Vorteile: Gute Zentrierung, geringe Gratbildung beim Durchbohren, genaue Bohrung in dünnen Blechen und Rohren, kein Einhaken. Lieferbar ab  $\varnothing 2,5$  mm.

Nachteile: Empfindlich gegen Stoß und einseitige Belastung. Einwandfreier Anschlag nur maschinell möglich.

## Sonstige Anschliffe und Ausspitzungen



### Form U: Sonderanschlag

Anwendung: Bei Bohrern mit stabilem, automationsgerechtem Profil, engnützig mit starkem Kern.

Vorteile: Sehr gutes Eigenzentrierverhalten bei Anwendung höchster Schnittwerte.

Kurze Späne durch konkave Schneiden. Nachteile: Erfordert Mehraufwand beim Nachschleifen.

# Für jeden Job die richtige Antwort

Spiralbohrer ist Spiralbohrer, sagen die einen.

Für jede Aufgabe das richtige Werkzeug, sagen wir.

## Spitzen- Technologie



259 xxx

## Premium mit Industriestandard



281 xxx



228 xxx

## Standard für professionelles Arbeiten



215 xxx



214 xxx



201 xxx

Das beginnt bereits bei den Spitzenanschliffen sowie den unterschiedlichen Spiral- und Spitzenwinkeln, die wesentlichen Einfluss auf das präzise Anbohrverhalten nehmen. Dazu gehören weiterhin die unterschiedlich ausgearbeiteten Nutprofile, die eine optimale Aufnahme und den Abtransport der Späne und damit dem Ausglühen oder sogar dem Brechen des Bohrers entgegenwirken. Oder aber die Kerndicke, die mitentscheidend für die Stabilität eines jeden Spiralbohrers ist.

So entstehen Spiralbohrer mit individueller Klasse. Für das klassische Handwerk, für Einsätze in der Industrie oder aber Aufgaben, für die ganz spezielle Lösungen gefordert sind.



203 xxx

258 xxx

### RUKO Spezialisten

200 xxx

204 xxx

202 xxx





























































































252 xxx

217 xxx

254 xxx































255 xxx

# Typen- und Anwendungsübersicht

	Werkstoff	Oberfläche	DIN	Typ	Spitzenanschliff	Spitzenwinkel	Spiralwinkel	Schaft	Ø mm	Art.-Nr.	Seite/n
	HSS	Blank	DIN 338	FT	 $\geq \text{Ø } 3.0 \text{ mm}$		 25-30°	 $\geq \text{Ø } 3.5 \text{ mm}$	1,0 – 13,0	259 xxx	23
	HSSE Co5	Bronze	DIN 338	FT	 $\geq \text{Ø } 3.0 \text{ mm}$		 25-30°	 $\geq \text{Ø } 3.5 \text{ mm}$			22
	HSSE Co8	Blank	DIN 338	VA	 $\geq \text{Ø } 2.0 \text{ mm}$	 130°	 36°		1,0 – 16,0	281 xxx	26 – 28
	HSSE Co8	TiAlN	DIN 338	VA	 $\geq \text{Ø } 2.0 \text{ mm}$	 130°	 36°				
	HSSE Co5	Bronze	DIN 338	VA	 $\geq \text{Ø } 2.0 \text{ mm}$	 130°	 36°		1,0 – 20,0	215 xxx	30 – 32
									1/16 – 1/2 Inch	215 8xx	33
	HSSE Co5	VAP Bonze	DIN 338	UNI	 $\geq \text{Ø } 2.0 \text{ mm}$	 130°	 40°	 $\geq \text{Ø } 4.0 \text{ mm}$	1,0 – 13,0	228 xxx	34
	HSS	Blank	DIN 338	TL 3000	 $\geq \text{Ø } 2.0 \text{ mm}$	 130°	 40°		1,0 – 16,0	258 xxx	36 – 37
	HSS	TiAlN	DIN 338	TL 3000	 $\geq \text{Ø } 2.0 \text{ mm}$	 130°	 40°				
	HSS	Blank	DIN 338	N	 $\geq \text{Ø } 2.0 \text{ mm}$	 118°	 25-30°		0,3 – 20,0	214 xxx	38 – 41
	HSS	TiN	DIN 338	N	 $\geq \text{Ø } 2.0 \text{ mm}$	 118°	 25-30°		0,3 – 16,0	250 xxx T	
	HSS	Blank	DIN 338	N	 $\geq \text{Ø } 2.0 \text{ mm}$	 118°	 25-30°		1/16 – 1/2 Inch	214 8xx	42
	HSS	TiN	DIN 338	N	 $\geq \text{Ø } 2.0 \text{ mm}$	 118°	 25-30°		1/16 – 1/2 Inch	250 8xx T	43
	HSS	TiN	DIN 338	N	 $\geq \text{Ø } 2.0 \text{ mm}$	 118°	 25-30°		1,0 – 13,0	2501 xxx	44
	HSS	Blank	DIN 338	N	 $\geq \text{Ø } 2.0 \text{ mm}$	 118°	 25-30°		1,0 – 13,0	214 xxx Li	45
	HSS-R	VAP	DIN 338	N	 $\geq \text{Ø } 2.0 \text{ mm}$	 118°	 25-30°		0,3 – 20,0	201 xxx	46 – 48
	HSS-R	VAP	DIN 338	N	 $\geq \text{Ø } 2.0 \text{ mm}$	 118°	 25-30°		10,5 – 25,0	200 xxx	49
	HSS	Blank	DIN 338	N	 $\geq \text{Ø } 2.0 \text{ mm}$	 118°	 25-30°		10,5 – 20,0	200 4 xxx	
	HSSE Co5	Bronze	DIN 338	N	 $\geq \text{Ø } 2.0 \text{ mm}$	 130°	 25-30°		10,5 – 20,0	200 5 xxx	
	HSS	Blank	DIN 340	N	 $\geq \text{Ø } 2.0 \text{ mm}$	 118°	 25-30°		2,5 – 13,0	203 xxx	50
	HSS	Blank	DIN 1869	TL 3000	 $\geq \text{Ø } 2.0 \text{ mm}$	 130°	 40°		2,0 – 13,0	254 xxx	51
									3,0 – 13,0	255 xxx	

Baustahl < 900 N/mm <sup>2</sup>	Inox < 1100 N/mm <sup>2</sup>	Hochfester Stahl < 1300 N/mm <sup>2</sup>	Messing	Bronze	Guss	Aluminium	Kunststoffe
●			●	○	○	●	○
●	●		●	○	○	●	○
○	●	●	●	○	●	●	○
○	●	●	●	●	●	●	○
●	●		●	○	○		○
●	●		●	○	○		○
●			●	○	○	●	○
●	●		●	●	○	●	○
●			●	○	○	●	○
●	○		●	○	○		○
●			●	○		●	○
●	○		●	○			○
●	○		●	○	○		○
●			●	○	○	●	○
●			●	○		●	○
●			●	○	○	●	○
●	●		●	○	○	●	○
●	●	●	●	●	●	●	○
●	○		●	○			○
●	○		●	○			○

# Typen- und Anwendungsübersicht

	Werkstoff	Oberfläche	DIN	Typ	Spitzenanschliff	Spitzenwinkel	Spiralwinkel	Schaft	Ø mm	Art.-Nr.	Seite/n
	HSS	VAP Blank	DIN 345	N					10,0 – 60,0	204 xxx	52 – 53
	HSSE Co5	Blank	DIN 345	N					10,0 – 30,0		
	HSSE Co5	Blank	DIN 1897	N					2,0 – 13,0	202 xxx E	54
	HSS	Blank	DIN 1897	N						202 xxx	55
	HSS	TiN	DIN 1897	N						202 xxx T	
	HSS	Blank		KV					2,5 – 6,5	252 xxx	56
	HSS	Blank	DIN 333	A					0,8 – 6,3	217 xxx	56

Baustahl < 900 N/mm <sup>2</sup>	Inox <1100 N/mm <sup>2</sup>	Hochfester Stahl <1300 N/mm <sup>2</sup>	Messing	Bronze	Guss	Aluminium	Kunststoffe
●			●	○		●	○
●	●		●	○	○	●	○
●	●		●	○	○	●	○
●			●	○	○	●	○
●			●	○	○		○
●			●	○	○	●	○
●			●	○	○	●	○

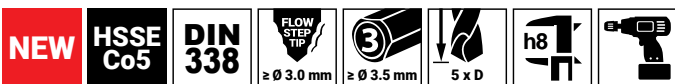

## ULTIMATECUT Spiralbohrer DIN 338 Typ FLOWSTEP<sup>®</sup>, HSSE-Co 5



### FLOWSTEP<sup>®</sup> Spitze

- Perfektes Zentrieren ohne Ankören auch auf runden Oberflächen wie z. B. Röhren.
- Leichter und ruhiger Bohrvorgang, ohne verkanten im Material.
- Extrem schnelles und kräfteschonendes Bohren.
- Zeitersparnis beim Bohren von bis zu 50 %.
- Deutlich längere Standzeit - bis zu 5 x mehr Bohrungen möglich.
- Optimal geeignet für den Einsatz in handgeführten (Akku-)Elektro-Werkzeugen.

**!** FLOWSTEP<sup>®</sup> Spitze ab  $\varnothing$  3.00, da aus technischer Anwendungssicht in den Größen kleiner  $\varnothing$  3.00 ohne Nutzensvorteil.

Verpackung: Kunststoff



$\varnothing$ mm	L1 mm	L2 mm	HSSE-Co 5	
1.00	34.0	12.0	259 010 E	10
1.50	40.0	18.0	259 015 E	10
2.00	49.0	24.0	259 020 E	10
2.50	57.0	30.0	259 025 E	10
3.00	61.0	33.0	259 030 E	10
3.30	65.0	36.0	259 033 E	10
3.50	70.0	39.0	259 035 E	10
4.00	75.0	43.0	259 040 E	10
4.20	75.0	43.0	259 042 E	10
4.50	80.0	47.0	259 045 E	10
5.00	86.0	52.0	259 050 E	10
5.50	93.0	57.0	259 055 E	5
6.00	93.0	57.0	259 060 E	5
6.50	101.0	63.0	259 065 E	5
6.80	109.0	69.0	259 068 E	5

$\varnothing$ mm	L1 mm	L2 mm	HSSE-Co 5	
7.00	109.0	69.0	259 070 E	5
7.50	109.0	69.0	259 075 E	5
8.00	117.0	75.0	259 080 E	5
8.50	117.0	75.0	259 085 E	1
9.00	125.0	81.0	259 090 E	1
9.50	125.0	81.0	259 095 E	1
10.00	133.0	87.0	259 100 E	1
10.20	133.0	87.0	259 102 E	1
10.50	133.0	87.0	259 105 E	1
11.00	142.0	94.0	259 110 E	1
11.50	142.0	94.0	259 115 E	1
12.00	151.0	101.0	259 120 E	1
12.50	151.0	101.0	259 125 E	1
13.00	151.0	101.0	259 130 E	1

		HSSE-Co 5
<b>19</b> tfg./pcs.	Spiralbohrer-Satz DIN 338 Typ FLOWSTEP <sup>®</sup> $\varnothing$ 1.0 mm bis 10.0 mm x 0.5 mm steigend	259 214 ERO
<b>25</b> tfg./pcs.	Spiralbohrer-Satz DIN 338 Typ FLOWSTEP <sup>®</sup> $\varnothing$ 1.0 mm bis 13.0 mm x 0.5 mm steigend	259 215 ERO



259 214 ERO



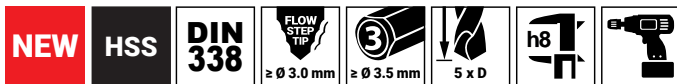

## ULTIMATECUT Spiralbohrer DIN 338 Typ FLOWSTEP®, HSS



### FLOWSTEP® Spitze

- Perfektes Zentrieren ohne Ankören auch auf runden Oberflächen wie z. B. Röhren.
- Leichter und ruhiger Bohrvorgang, ohne verkanten im Material.
- Extrem schnelles und kräfteschonendes Bohren.
- Zeitersparnis beim Bohren von bis zu 50 %.
- Deutlich längere Standzeit - bis zu 5 x mehr Bohrungen möglich.
- Optimal geeignet für den Einsatz in handgeführten (Akku-)Elektro-Werkzeugen.



**!** FLOWSTEP® Spitze ab Ø 3.00, da aus technischer Anwendungssicht in den Größen kleiner Ø 3.00 ohne Nutzenvorteil.

Verpackung: Kunststoff

Ø mm	L1 mm	L2 mm	HSS	
1.00	34.0	12.0	259 010	10
1.50	40.0	18.0	259 015	10
2.00	49.0	24.0	259 020	10
2.50	57.0	30.0	259 025	10
3.00	61.0	33.0	259 030	10
3.30	65.0	36.0	259 033	10
3.50	70.0	39.0	259 035	10
4.00	75.0	43.0	259 040	10
4.20	75.0	43.0	259 042	10
4.50	80.0	47.0	259 045	10
5.00	86.0	52.0	259 050	10
5.50	93.0	57.0	259 055	5
6.00	93.0	57.0	259 060	5
6.50	101.0	63.0	259 065	5
6.80	109.0	69.0	259 068	5

Ø mm	L1 mm	L2 mm	HSS	
7.00	109.0	69.0	259 070	5
7.50	109.0	69.0	259 075	5
8.00	117.0	75.0	259 080	5
8.50	117.0	75.0	259 085	1
9.00	125.0	81.0	259 090	1
9.50	125.0	81.0	259 095	1
10.00	133.0	87.0	259 100	1
10.20	133.0	87.0	259 102	1
10.50	133.0	87.0	259 105	1
11.00	142.0	94.0	259 110	1
11.50	142.0	94.0	259 115	1
12.00	151.0	101.0	259 120	1
12.50	151.0	101.0	259 125	1
13.00	151.0	101.0	259 130	1

		HSS
<b>19</b> tlg./pcs.	Spiralbohrer-Satz DIN 338 Typ FLOWSTEP® Ø 1.0 mm bis 10.0 mm x 0.5 mm steigend	259 214 RO
<b>25</b> tlg./pcs.	Spiralbohrer-Satz DIN 338 Typ FLOWSTEP® Ø 1.0 mm bis 13.0 mm x 0.5 mm steigend	259 215 RO



259 215 RO

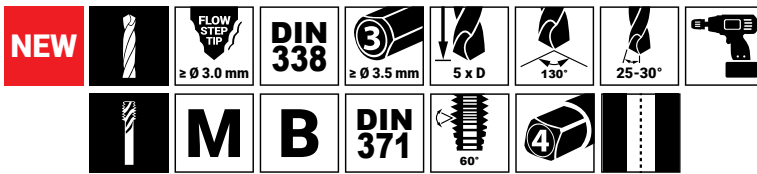

## ULTIMATECUT Spiralbohrer DIN 338 Typ FLOWSTEP® + Maschinengewindebohrer M DIN 371 / 376 Form B



		HSS
<b>14</b> Stg./pcs.	Maschinengewindebohrer-Satz 7 ULTIMATECUT Spiralbohrer DIN 338 Typ FLOWSTEP® Ø 2.5   3.3   4.2   5.0   6.8   8.5   10.2 mm + 7 Maschinengewindebohrer M DIN 371 / 376 Form B mit Schälanschnitt M 3   M 4   M 5   M 6   M 8   M 10   M 12	259 048 RO



		HSSE-Co 5
<b>14</b> Stg./pcs.	Maschinengewindebohrer-Satz 7 ULTIMATECUT Spiralbohrer DIN 338 Typ FLOWSTEP® Ø 2.5   3.3   4.2   5.0   6.8   8.5   10.2 mm + 7 Maschinengewindebohrer M DIN 371 / 376 Form B mit Schälanschnitt M 3   M 4   M 5   M 6   M 8   M 10   M 12	259 048 ERO

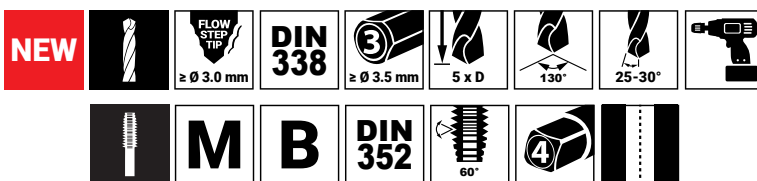

## ULTIMATECUT Spiralbohrer DIN 338 Typ FLOWSTEP® + Einschnittgewindebohrer M ≈ DIN 352 HSS



		HSS
<b>15</b> Stg./pcs.	Einschnittgewindebohrer-Satz 7 ULTIMATECUT Spiralbohrer DIN 338 Typ FLOWSTEP® HSS Ø 2.5   3.3   4.2   5.0   6.8   8.5   10.2 mm + 7 Einschnittgewindebohrer M ≈ DIN 352 HSS, M 3   M 4   M 5   M 6   M 8   M 10   M 12	259 004 RO





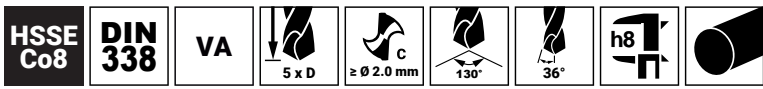

## Spiralbohrer DIN 338 Typ VA, HSSE-Co 8

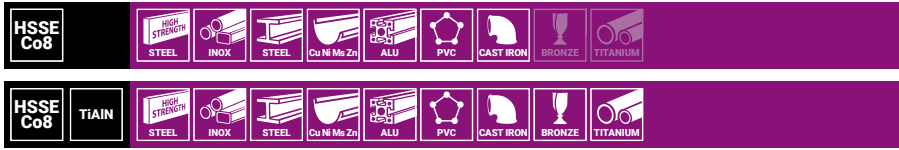



Kräftiger Sonderbohrer, der vorzugsweise für Titanlegierungen sowie rost-, säure- und hitzebeständigen austenitischen Stählen verwendbar ist. Weiter ist er für hochfeste Stähle mit niedriger Zähigkeit geeignet. Unter bestimmten Bedingungen kann dieser Bohrer für Sonderlegierungen wie Hastelloy, Inconel, Nimonic, usw. verwendet werden.



Verpackung: Kunststoff

Ø mm	L1 mm	L2 mm	HSSE-Co 8		HSSE-Co 8 TiAIN	
			Part No.	Pkg	Part No.	Pkg
1.00	34.0	12.0	281 010 E	10	281 010 EF	10
1.10	36.0	14.0	281 011 E	10	281 011 EF	10
1.20	38.0	16.0	281 012 E	10	281 012 EF	10
1.30	38.0	16.0	281 013 E	10	281 013 EF	10
1.40	40.0	18.0	281 014 E	10	281 014 EF	10
1.50	40.0	18.0	281 015 E	10	281 015 EF	10
1.60	43.0	20.0	281 016 E	10	281 016 EF	10
1.70	43.0	20.0	281 017 E	10	281 017 EF	10
1.80	46.0	22.0	281 018 E	10	281 018 EF	10
1.90	46.0	22.0	281 019 E	10	281 019 EF	10
2.00	49.0	24.0	281 020 E	10	281 020 EF	10
2.10	49.0	24.0	281 021 E	10	281 021 EF	10
2.20	53.0	27.0	281 022 E	10	281 022 EF	10
2.30	53.0	27.0	281 023 E	10	281 023 EF	10
2.40	57.0	30.0	281 024 E	10	281 024 EF	10
2.50	57.0	30.0	281 025 E	10	281 025 EF	10
2.60	57.0	30.0	281 026 E	10	281 026 EF	10
2.70	61.0	33.0	281 027 E	10	281 027 EF	10
2.80	61.0	33.0	281 028 E	10	281 028 EF	10
2.90	61.0	33.0	281 029 E	10	281 029 EF	10
3.00	61.0	33.0	281 030 E	10	281 030 EF	10
3.10	65.0	36.0	281 031 E	10	281 031 EF	10
3.20	65.0	36.0	281 032 E	10	281 032 EF	10
3.30	65.0	36.0	281 033 E	10	281 033 EF	10
3.40	70.0	39.0	281 034 E	10	281 034 EF	10
3.50	70.0	39.0	281 035 E	10	281 035 EF	10
3.60	70.0	39.0	281 036 E	10	281 036 EF	10
3.70	70.0	39.0	281 037 E	10	281 037 EF	10
3.80	75.0	43.0	281 038 E	10	281 038 EF	10
3.90	75.0	43.0	281 039 E	10	281 039 EF	10
4.00	75.0	43.0	281 040 E	10	281 040 EF	10
4.10	75.0	43.0	281 041 E	10	281 041 EF	10
4.20	75.0	43.0	281 042 E	10	281 042 EF	10
4.30	80.0	47.0	281 043 E	10	281 043 EF	10
4.40	80.0	47.0	281 044 E	10	281 044 EF	10
4.50	80.0	47.0	281 045 E	10	281 045 EF	10
4.60	80.0	47.0	281 046 E	10	281 046 EF	10
4.70	80.0	47.0	281 047 E	10	281 047 EF	10
4.80	86.0	52.0	281 048 E	10	281 048 EF	10
4.90	86.0	52.0	281 049 E	10	281 049 EF	10

Ø mm	L1 mm	L2 mm	HSSE-Co 8		HSSE-Co 8 TiAlN	
						
5.00	86.0	52.0	281 050 E	10	281 050 EF	10
5.10	86.0	52.0	281 051 E	10	281 051 EF	10
5.20	86.0	52.0	281 052 E	10	281 052 EF	10
5.30	86.0	52.0	281 053 E	10	281 053 EF	10
5.40	93.0	57.0	281 054 E	10	281 054 EF	10
5.50	93.0	57.0	281 055 E	10	281 055 EF	10
5.60	93.0	57.0	281 056 E	10	281 056 EF	10
5.70	93.0	57.0	281 057 E	10	281 057 EF	10
5.80	93.0	57.0	281 058 E	10	281 058 EF	10
5.90	93.0	57.0	281 059 E	10	281 059 EF	10
6.00	93.0	57.0	281 060 E	10	281 060 EF	10
6.10	101.0	63.0	281 061 E	10	281 061 EF	10
6.20	101.0	63.0	281 062 E	10	281 062 EF	10
6.30	101.0	63.0	281 063 E	10	281 063 EF	10
6.40	101.0	63.0	281 064 E	10	281 064 EF	10
6.50	101.0	63.0	281 065 E	10	281 065 EF	10
6.60	101.0	63.0	281 066 E	10	281 066 EF	10
6.70	101.0	63.0	281 067 E	10	281 067 EF	10
6.80	109.0	69.0	281 068 E	10	281 068 EF	10
6.90	109.0	69.0	281 069 E	10	281 069 EF	10
7.00	109.0	69.0	281 070 E	10	281 070 EF	10
7.10	109.0	69.0	281 071 E	10	281 071 EF	10
7.20	109.0	69.0	281 072 E	10	281 072 EF	10
7.30	109.0	69.0	281 073 E	10	281 073 EF	10
7.40	109.0	69.0	281 074 E	10	281 074 EF	10
7.50	109.0	69.0	281 075 E	10	281 075 EF	10
7.60	117.0	75.0	281 076 E	10	281 076 EF	10
7.70	117.0	75.0	281 077 E	10	281 077 EF	10
7.80	117.0	75.0	281 078 E	10	281 078 EF	10
7.90	117.0	75.0	281 079 E	10	281 079 EF	10
8.00	117.0	75.0	281 080 E	10	281 080 EF	10
8.10	117.0	75.0	281 081 E	10	281 081 EF	10
8.20	117.0	75.0	281 082 E	10	281 082 EF	10
8.30	117.0	75.0	281 083 E	10	281 083 EF	10
8.40	117.0	75.0	281 084 E	10	281 084 EF	10
8.50	117.0	75.0	281 085 E	10	281 085 EF	10
8.60	125.0	81.0	281 086 E	10	281 086 EF	10
8.70	125.0	81.0	281 087 E	10	281 087 EF	10
8.80	125.0	81.0	281 088 E	10	281 088 EF	10
8.90	125.0	81.0	281 089 E	10	281 089 EF	10
9.00	125.0	81.0	281 090 E	10	281 090 EF	10
9.10	125.0	81.0	281 091 E	10	281 091 EF	10
9.20	125.0	81.0	281 092 E	10	281 092 EF	10
9.30	125.0	81.0	281 093 E	10	281 093 EF	10
9.40	125.0	81.0	281 094 E	10	281 094 EF	10
9.50	125.0	81.0	281 095 E	10	281 095 EF	10
9.60	133.0	87.0	281 096 E	10	281 096 EF	10
9.70	133.0	87.0	281 097 E	10	281 097 EF	10
9.80	133.0	87.0	281 098 E	10	281 098 EF	10
9.90	133.0	87.0	281 099 E	10	281 099 EF	10
10.00	133.0	87.0	281 100 E	10	281 100 EF	10
10.20	133.0	87.0	281 102 E	10	281 102 EF	10
10.50	133.0	87.0	281 105 E	5	281 105 EF	5
11.00	142.0	94.0	281 110 E	5	281 110 EF	5
11.50	142.0	94.0	281 115 E	5	281 115 EF	5
12.00	151.0	101.0	281 120 E	5	281 120 EF	5
12.50	151.0	101.0	281 125 E	5	281 125 EF	5
13.00	151.0	101.0	281 130 E	5	281 130 EF	5
13.50	160.0	108.0	281 135 E	5	281 135 EF	5
14.00	160.0	108.0	281 140 E	5	281 140 EF	5
14.50	169.0	114.0	281 145 E	5	281 145 EF	5
15.00	169.0	114.0	281 150 E	5	281 150 EF	5
15.50	178.0	120.0	281 155 E	5	281 155 EF	5
16.00	178.0	120.0	281 160 E	5	281 160 EF	5

01

		HSSE-Co 8	HSSE-Co 8 TiAlN
19 tfg./pcs.	Spiralbohrer-Satz DIN 338 Typ VA Ø 1.0 mm bis 10.0 mm x 0.5 mm steigend	281 214 ERO	281 214 EFRO
25 tfg./pcs.	Spiralbohrer-Satz DIN 338 Typ VA Ø 1.0 mm bis 13.0 mm x 0.5 mm steigend	281 215 ERO	281 215 EFRO



281 214 ERO



281 214 EFRO



281 215 EFRO

**i**

## Kühl- und Schmierstoffe

RUKO Kühl- und Schmierstoffe zeigen eine hervorragende Trenn- und Kühlwirkung. Sie erzeugen eine hohe Oberflächengüte und erhöhen die Werkzeugstandzeiten auch bei harten und spröden Materialien.

Passend auf unser Sortiment abgestimmt finden Sie die Kühl- und Schmierstoffe in unserem Kapitel 14, Seite 303.







## Spiralbohrer DIN 338 Typ VA, HSSE-Co 5



Kräftiger rechtsschneidender Hochleistungsbohrer mit ausgeprägter Warmhärtebeständigkeit. Ideal zum Bohren von rost-, säure- und hitzebeständigem Stahl mit hoher Festigkeit.





Verpackung: Kunststoff

Ø mm	L1 mm	L2 mm	HSSE-Co 5	
1.00	34.0	12.0	215 010	10
1.10	36.0	14.0	215 011	10
1.20	38.0	16.0	215 012	10
1.25	38.0	16.0	215 0125	10
1.30	38.0	16.0	215 013	10
1.40	40.0	18.0	215 014	10
1.50	40.0	18.0	215 015	10
1.60	43.0	20.0	215 016	10
1.70	43.0	20.0	215 017	10
1.75	46.0	22.0	215 0175	10
1.80	46.0	22.0	215 018	10
1.90	46.0	22.0	215 019	10
2.00	49.0	24.0	215 020	10
2.10	49.0	24.0	215 021	10
2.20	53.0	27.0	215 022	10
2.25	53.0	27.0	215 0225	10
2.30	53.0	27.0	215 023	10
2.40	57.0	30.0	215 024	10
2.50	57.0	30.0	215 025	10
2.60	57.0	30.0	215 026	10
2.70	61.0	33.0	215 027	10
2.75	61.0	33.0	215 0275	10
2.80	61.0	33.0	215 028	10
2.90	61.0	33.0	215 029	10
3.00	61.0	33.0	215 030	10
3.10	65.0	36.0	215 031	10
3.20	65.0	36.0	215 032	10
3.25	65.0	36.0	215 0325	10
3.30	65.0	36.0	215 033	10
3.40	70.0	39.0	215 034	10
3.50	70.0	39.0	215 035	10
3.60	70.0	39.0	215 036	10
3.70	70.0	39.0	215 037	10
3.75	70.0	39.0	215 0375	10
3.80	75.0	43.0	215 038	10
3.90	75.0	43.0	215 039	10
4.00	75.0	43.0	215 040	10
4.10	75.0	43.0	215 041	10
4.20	75.0	43.0	215 042	10
4.25	75.0	43.0	215 0425	10

Ø mm	L1 mm	L2 mm	HSSE-Co 5	
4.30	80.0	47.0	215 043	10
4.40	80.0	47.0	215 044	10
4.50	80.0	47.0	215 045	10
4.60	80.0	47.0	215 046	10
4.70	80.0	47.0	215 047	10
4.75	80.0	47.0	215 0475	10
4.80	86.0	52.0	215 048	10
4.90	86.0	52.0	215 049	10
5.00	86.0	52.0	215 050	10
5.10	86.0	52.0	215 051	10
5.20	86.0	52.0	215 052	10
5.25	86.0	52.0	215 0525	10
5.30	86.0	52.0	215 053	10
5.40	93.0	57.0	215 054	10
5.50	93.0	57.0	215 055	10
5.60	93.0	57.0	215 056	10
5.70	93.0	57.0	215 057	10
5.75	93.0	57.0	215 0575	10
5.80	93.0	57.0	215 058	10
5.90	93.0	57.0	215 059	10
6.00	93.0	57.0	215 060	10
6.10	101.0	63.0	215 061	10
6.20	101.0	63.0	215 062	10
6.25	101.0	63.0	215 0625	10
6.30	101.0	63.0	215 063	10
6.40	101.0	63.0	215 064	10
6.50	101.0	63.0	215 065	10
6.60	101.0	63.0	215 066	10
6.70	101.0	63.0	215 067	10
6.75	101.0	63.0	215 0675	10
6.80	109.0	69.0	215 068	10
6.90	109.0	69.0	215 069	10
7.00	109.0	69.0	215 070	10
7.10	109.0	69.0	215 071	10
7.20	109.0	69.0	215 072	10
7.25	109.0	69.0	215 0725	10
7.30	109.0	69.0	215 073	10
7.40	109.0	69.0	215 074	10
7.50	109.0	69.0	215 075	10
7.60	117.0	75.0	215 076	10



Ø mm	L1 mm	L2 mm	HSSE-Co 5	
7.70	117.0	75.0	215 077	10
7.75	117.0	75.0	215 0775	10
7.80	117.0	75.0	215 078	10
7.90	117.0	75.0	215 079	10
8.00	117.0	75.0	215 080	10
8.10	117.0	75.0	215 081	10
8.20	117.0	75.0	215 082	10
8.25	117.0	75.0	215 0825	10
8.30	117.0	75.0	215 083	10
8.40	117.0	75.0	215 084	10
8.50	117.0	75.0	215 085	10
8.60	125.0	81.0	215 086	10
8.70	125.0	81.0	215 087	10
8.75	125.0	81.0	215 0875	10
8.80	125.0	81.0	215 088	10
8.90	125.0	81.0	215 089	10
9.00	125.0	81.0	215 090	10
9.10	125.0	81.0	215 091	10
9.20	125.0	81.0	215 092	10
9.25	125.0	81.0	215 0925	10
9.30	125.0	81.0	215 093	10
9.40	125.0	81.0	215 094	10
9.50	125.0	81.0	215 095	10
9.60	133.0	87.0	215 096	10
9.70	133.0	87.0	215 097	10
9.75	133.0	87.0	215 0975	10
9.80	133.0	87.0	215 098	10
9.90	133.0	87.0	215 099	10
10.00	133.0	87.0	215 100	10
10.10	133.0	87.0	215 101	10
10.20	133.0	87.0	215 102	10
10.30	133.0	87.0	215 103	10
10.40	133.0	87.0	215 104	10
10.50	133.0	87.0	215 105	5
10.60	133.0	87.0	215 106	5
10.70	142.0	94.0	215 107	5
10.80	142.0	94.0	215 108	5

Ø mm	L1 mm	L2 mm	HSSE-Co 5	
10.90	142.0	94.0	215 109	5
11.00	142.0	94.0	215 110	5
11.10	142.0	94.0	215 111	5
11.20	142.0	94.0	215 112	5
11.30	142.0	94.0	215 113	5
11.40	142.0	94.0	215 114	5
11.50	142.0	94.0	215 115	5
11.60	142.0	94.0	215 116	5
11.70	142.0	94.0	215 117	5
11.80	142.0	94.0	215 118	5
11.90	151.0	101.0	215 119	5
12.00	151.0	101.0	215 120	5
12.10	151.0	101.0	215 121	5
12.20	151.0	101.0	215 122	5
12.30	151.0	101.0	215 123	5
12.40	151.0	101.0	215 124	5
12.50	151.0	101.0	215 125	5
12.60	151.0	101.0	215 126	5
12.70	151.0	101.0	215 127	5
12.80	151.0	101.0	215 128	5
12.90	151.0	101.0	215 129	5
13.00	151.0	101.0	215 130	5
13.50	160.0	108.0	215 135	5
14.00	160.0	108.0	215 140	5
14.50	169.0	114.0	215 145	5
15.00	169.0	114.0	215 150	5
15.50	178.0	120.0	215 155	5
16.00	178.0	120.0	215 160	5
16.50	184.0	125.0	215 165	1
17.00	184.0	125.0	215 170	1
17.50	191.0	130.0	215 175	1
18.00	191.0	130.0	215 180	1
18.50	198.0	135.0	215 185	1
19.00	198.0	135.0	215 190	1
19.50	205.0	140.0	215 195	1
20.00	205.0	140.0	215 210	1

		HSSE-Co 5
<b>19</b> tlg./pcs.	Spiralbohrer-Satz DIN 338 Typ VA Ø 1.0 mm bis 10.0 mm x 0.5 mm steigend	215 214 RO
<b>24</b> tlg./pcs.	Spiralbohrer-Satz DIN 338 Typ VA Ø 1.0 mm bis 10.5 mm x 0.5 mm steigend + 3.3 / 4.2 / 6.8 / 10.2 mm	215 216 RO
<b>25</b> tlg./pcs.	Spiralbohrer-Satz DIN 338 Typ VA Ø 1.0 mm bis 13.0 mm x 0.5 mm steigend	215 215 RO
<b>41</b> tlg./pcs.	Spiralbohrer-Satz DIN 338 Typ VA Ø 6.0 mm bis 10.0 mm x 0.1 mm steigend	215 218 RO
<b>50</b> tlg./pcs.	Spiralbohrer-Satz DIN 338 Typ VA Ø 1.0 mm bis 5.9 mm x 0.1 mm steigend	215 217 RO



215 214 RO



215 216 RO



215 218 RO



215 217 RO

		HSSE-Co 5
<b>91</b> <small>tlg./pcs.</small>	Spiralbohrer-Satz im Werkbankständer Ø 1.0 mm bis 10.0 mm x 0.1 mm steigend	215 223
<b>170</b> <small>tlg./pcs.</small>	Spiralbohrer-Satz im Magazin je 10 Stück Ø 1.0 - 8.0 mm x 0.5 mm steigend je 5 Stück Ø 8.5 - 10.0 mm x 0.5 mm steigend	215 200 RO
<b>570</b> <small>tlg./pcs.</small>	Bohrer-Schrank, bestückt je 50 Stück Ø 1.0 - 2.5 mm x 0.5 mm steigend je 30 Stück Ø 3.0 - 5.5 mm x 0.5 mm steigend je 20 Stück Ø 6.0 - 7.5 mm x 0.5 mm steigend je 10 Stück Ø 8.0 - 13.0 mm x 0.5 mm steigend	215 208
	Bohrer-Schrank leer Maße: H1: 23.0 cm. L1: 37.0 cm. T1: 9.5 cm. T2: 20.0 cm Ø 1.0 mm bis 13.0 mm x 0.5 mm steigend	205 208 L
	Bohrer-Schrank leer Maße: H1: 46.5 cm. L1: 39.0 cm. T1: 9.5 cm. T2: 20.0 cm Ø 1.0 mm bis 10.0 mm x 0.1 mm steigend Ø 10.5 mm bis 13.0 mm x 0.5 mm steigend	205 2081 L



215 223



215 200 RO



205 208 L



## Spiralbohrer DIN 338 Typ VA, HSSE-Co 5 – Zollabmessungen



Kräftiger rechtsschneidender Hochleistungsbohrer mit ausgeprägter Warmhärtebeständigkeit. Ideal zum Bohren von rost-, säure- und hitzebeständigem Stahl mit hoher Festigkeit.



**Inch Size**



Verpackung: Kunststoff

Ø Zoll	Ø mm	L1 Zoll	L2 Zoll	HSSE-Co 5	
1/16	1,59	1 7/8	7/8	215 801	10
5/64	1,98	2	1	215 802	10
3/32	2,38	2 1/4	1 1/4	215 803	10
7/64	2,78	2 5/8	1 1/2	215 804	10
1/8	3,18	2 3/4	1 5/8	215 805	10
9/64	3,57	2 7/8	1 3/4	215 806	10
5/32	3,97	3 1/8	2	215 807	10
11/64	4,37	3 1/4	2 1/8	215 808	10
3/16	4,76	3 1/2	2 5/16	215 809	10
13/64	5,16	3 5/8	2 7/16	215 810	10
7/32	5,56	3 3/4	2 1/2	215 811	10
15/64	5,95	3 7/8	2 5/8	215 812	10
1/4	6,35	4	2 3/4	215 813	10
17/64	6,75	4 1/8	2 7/8	215 814	10
9/32	7,14	4 1/4	2 15/16	215 815	10

Ø Zoll	Ø mm	L1 Zoll	L2 Zoll	HSSE-Co 5	
19/64	7,54	4 3/8	3 1/16	215 816	10
5/16	7,94	4 1/2	3 3/16	215 817	10
21/64	8,33	4 5/8	3 5/16	215 818	10
11/32	8,73	4 3/4	3 7/16	215 819	10
23/64	9,13	4 7/8	3 1/2	215 820	10
3/8	9,53	5	3 5/8	215 821	10
25/64	9,92	5 1/8	3 3/4	215 822	10
13/32	10,32	5 1/4	3 7/8	215 823	10
27/64	10,72	5 3/8	3 15/16	215 824	5
7/16	11,11	5 1/2	4 1/16	215 825	5
29/64	11,51	5 5/8	4 3/16	215 826	5
15/32	11,91	5 3/4	4 5/16	215 827	5
31/64	12,30	5 7/8	4 3/8	215 828	5
1/2	12,70	6	4 1/2	215 829	5

		HSSE-Co 5
<b>21</b> tlg./ pcs.	Spiralbohrer-Satz DIN 338 Typ VA Ø 1/16" bis 3/8" x 1/64" steigend	215 850 RO
<b>29</b> tlg./ pcs.	Spiralbohrer-Satz DIN 338 Typ VA Ø 1/16" bis 1/2" x 1/64" steigend	215 851 RO



215 850 RO



## Spiralbohrer DIN 338 Typ UNI, HSSE-Co 5



- Der Dreiflächenschaft sorgt für hervorragende Fixierung im Bohrfutter bei geringem Kraftaufwand.
- Zudem sorgt der Schaft für eine optimale Kraftübertragung. Kein Durchdrehen des Bohrers!
- Die 135° Hochleistungsschneide sorgt für eine sehr hohe Zentriergenauigkeit, insbesondere bei handgeführten Anwendungen mit dem Akku-Bohrschrauber. Die Schneide verhindert das Abrutschen beim Anbohren von gewölbten Oberflächen.
- Erhöhte Lebensdauer des Akkus durch Verringerung der Schnittkräfte.
- Die schwarze Fase erhöht die Verschleißfestigkeit und verhindert Kaltverschweißungen und Aufbauschnitten.
- Der 40° Drallwinkel ermöglicht eine perfekte und schnelle Spanabfuhr und sorgt für hohe Schnittgeschwindigkeiten bei erhöhter Stabilität und Genauigkeit.

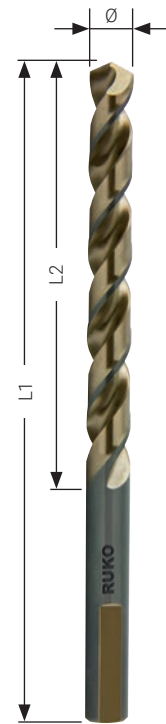

### **i** Anwendungstipp

Dieser Hochleistungsspiralbohrer wurde speziell für den portablen Einsatz in Bohrmaschinen und Akku-Bohrschraubern entwickelt. (Beste Leistung bis 5,0 mm Materialstärke).



Verpackung: Kunststoff

Ø mm	L1 mm	L2 mm	HSSE-Co 5	
1.00	34.0	12.0	228 010	10
1.50	40.0	18.0	228 015	10
2.00	49.0	24.0	228 020	10
2.50	57.0	30.0	228 025	10
3.00	61.0	33.0	228 030	10
3.30	65.0	36.0	228 033	10
3.50	70.0	39.0	228 035	10
4.00	75.0	43.0	228 040	10
4.20	75.0	43.0	228 042	10
4.50	80.0	47.0	228 045	10
5.00	86.0	52.0	228 050	10
5.50	93.0	57.0	228 055	10
6.00	93.0	57.0	228 060	10
6.50	101.0	63.0	228 065	10
6.80	109.0	69.0	228 068	10

Ø mm	L1 mm	L2 mm	HSSE-Co 5	
7.00	109.0	69.0	228 070	10
7.50	109.0	69.0	228 075	10
8.00	117.0	75.0	228 080	10
8.50	117.0	75.0	228 085	10
9.00	125.0	81.0	228 090	10
9.50	125.0	81.0	228 095	10
10.00	133.0	87.0	228 100	10
10.20	133.0	87.0	228 102	10
10.50	133.0	87.0	228 105	5
11.00	142.0	94.0	228 110	5
11.50	142.0	94.0	228 115	5
12.00	151.0	101.0	228 120	5
12.50	151.0	101.0	228 125	5
13.00	151.0	101.0	228 130	5

		HSSE-Co 5
<b>19</b> tfg./pcs.	Spiralbohrer-Satz DIN 338 Typ UNI Ø 1.0 mm bis 10.0 mm x 0.5 mm steigend	228 214 RO
<b>25</b> tfg./pcs.	Spiralbohrer-Satz DIN 338 Typ UNI Ø 1.0 mm bis 13.0 mm x 0.5 mm steigend	228 215 RO



228 214 RO





# Spiralbohrer DIN 338 TL 3000, HSS

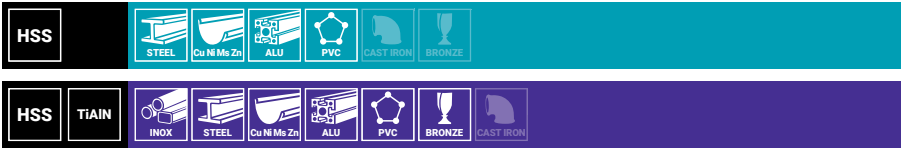

Stabiler Mehrbereichsbohrer mit verstärktem Bohrerkerne und einer parabolisch geformten Spannutt zur idealen Spanabfuhr. Ideal zum Bohren von mittel- und langspannenden Werkstoffen. Durch seinen dicken Kern und die spezielle Spannutt mit gerundeter hinterer Kante ist dieser Bohrer für Hochleistungsanwendungen bestens geeignet. Er deckt in weiten Bereichen die Typen N, H und W ab.



Verpackung: Kunststoff

Ø mm	L1 mm	L2 mm	HSS TiAlN	
1.00	34.0	12.0	258 010 F	10
1.50	40.0	18.0	258 015 F	10
2.00	49.0	24.0	258 020 F	10
2.50	57.0	30.0	258 025 F	10
3.00	61.0	33.0	258 030 F	10
3.30	65.0	36.0	258 033 F	10
3.50	70.0	39.0	258 035 F	10
4.00	75.0	43.0	258 040 F	10
4.20	75.0	43.0	258 042 F	10
4.50	80.0	47.0	258 045 F	10
5.00	86.0	52.0	258 050 F	10
5.50	93.0	57.0	258 055 F	10
6.00	93.0	57.0	258 060 F	10
6.50	101.0	63.0	258 065 F	10
6.80	109.0	69.0	258 068 F	10
7.00	109.0	69.0	258 070 F	10
7.50	109.0	69.0	258 075 F	10
8.00	117.0	75.0	258 080 F	10
8.50	117.0	75.0	258 085 F	10
9.00	125.0	81.0	258 090 F	10
9.50	125.0	81.0	258 095 F	10
10.00	133.0	87.0	258 100 F	10
10.20	133.0	87.0	258 102 F	10
10.50	133.0	87.0	258 105 F	5
11.00	142.0	94.0	258 110 F	5
11.50	142.0	94.0	258 115 F	5
12.00	151.0	101.0	258 120 F	5
12.50	151.0	101.0	258 125 F	5
13.00	151.0	101.0	258 130 F	5
13.50	160.0	108.0	258 135 F	5
14.00	160.0	108.0	258 140 F	5
14.50	169.0	114.0	258 145 F	5
15.00	169.0	114.0	258 150 F	5
15.50	178.0	120.0	258 155 F	5
16.00	178.0	120.0	258 160 F	5

HSS	
258 010	10
258 015	10
258 020	10
258 025	10
258 030	10
258 033	10
258 035	10
258 040	10
258 042	10
258 045	10
258 050	10
258 055	10
258 060	10
258 065	10
258 068	10
258 070	10
258 075	10
258 080	10
258 085	10
258 090	10
258 095	10
258 100	10
258 102	10
258 105	5
258 110	5
258 115	5
258 120	5
258 125	5
258 130	5
258 135	5
258 140	5
258 145	5
258 150	5
258 155	5
258 160	5

		HSS TiAIN	HSS
<b>19</b> Stk./pcs.	Spiralbohrer-Satz DIN 338 TL 3000, HSS Ø 1.0 mm bis 10.0 mm x 0.5 mm steigend	258 214 FRO	258 214 RO
<b>25</b> Stk./pcs.	Spiralbohrer-Satz DIN 338 TL 3000, HSS Ø 1.0 mm bis 13.0 mm x 0.5 mm steigend	258 215 FRO	258 215 RO



258 214 RO



258 214 FRO



258 215 RO



258 215 FRO

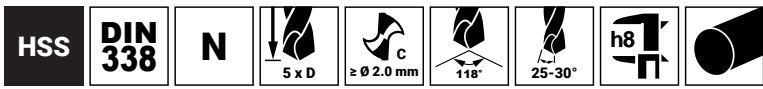

# Spiralbohrer DIN 338 Typ N, HSS

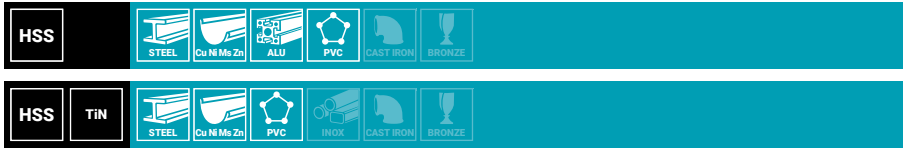



Leistungsstarker, geschliffener Standard-Spiralbohrer aus Schnellarbeitsstahl. Der komplett geschliffene Spiralbohrer verfügt über eine präzise Rundlaufgenauigkeit. Durch den Kreuzanschliff hat dieser Bohrer eine gute Zentrierung und benötigt eine geringe Vorschubkraft.





Verpackung: Kunststoff

Ø mm	L1 mm	L2 mm	HSS		HSS TiN	
			Part No.	Pkg	Part No.	Pkg
0.30	19.0	3.0	214 003	10	250 003 T	10
0.40	20.0	5.0	214 004	10	250 004 T	10
0.50	22.0	6.0	214 005	10	250 005 T	10
0.60	24.0	7.0	214 006	10	250 006 T	10
0.70	28.0	9.0	214 007	10	250 007 T	10
0.80	30.0	10.0	214 008	10	250 008 T	10
0.90	32.0	11.0	214 009	10	250 009 T	10
1.00	34.0	12.0	214 010	10	250 010 T	10
1.10	36.0	14.0	214 011	10	250 011 T	10
1.20	38.0	16.0	214 012	10	250 012 T	10
1.25	38.0	16.0	214 0125	10	250 0125 T	10
1.30	38.0	16.0	214 013	10	250 013 T	10
1.40	40.0	18.0	214 014	10	250 014 T	10
1.50	40.0	18.0	214 015	10	250 015 T	10
1.60	43.0	20.0	214 016	10	250 016 T	10
1.70	43.0	20.0	214 017	10	250 017 T	10
1.75	46.0	20.0	214 0175	10	250 0175 T	10
1.80	46.0	22.0	214 018	10	250 018 T	10
1.90	46.0	22.0	214 019	10	250 019 T	10
2.00	49.0	24.0	214 020	10	250 020 T	10
2.10	49.0	24.0	214 021	10	250 021 T	10
2.20	53.0	27.0	214 022	10	250 022 T	10
2.25	53.0	27.0	214 0225	10	250 0225 T	10
2.30	53.0	27.0	214 023	10	250 023 T	10
2.40	57.0	30.0	214 024	10	250 024 T	10
2.50	57.0	30.0	214 025	10	250 025 T	10
2.60	57.0	30.0	214 026	10	250 026 T	10
2.70	61.0	33.0	214 027	10	250 027 T	10
2.75	61.0	33.0	214 0275	10	250 0275 T	10
2.80	61.0	33.0	214 028	10	250 028 T	10
2.90	61.0	33.0	214 029	10	250 029 T	10
3.00	61.0	33.0	214 030	10	250 030 T	10
3.10	65.0	36.0	214 031	10	250 031 T	10
3.20	65.0	36.0	214 032	10	250 032 T	10
3.25	65.0	36.0	214 0325	10	250 0325 T	10
3.30	65.0	36.0	214 033	10	250 033 T	10
3.40	70.0	39.0	214 034	10	250 034 T	10
3.50	70.0	39.0	214 035	10	250 035 T	10
3.60	70.0	39.0	214 036	10	250 036 T	10
3.70	70.0	39.0	214 037	10	250 037 T	10



Ø mm	L1 mm	L2 mm	HSS		HSS TiN	
3.75	70.0	39.0	214 0375	10	250 0375 T	10
3.80	75.0	43.0	214 038	10	250 038 T	10
3.90	75.0	43.0	214 039	10	250 039 T	10
4.00	75.0	43.0	214 040	10	250 040 T	10
4.10	75.0	43.0	214 041	10	250 041 T	10
4.20	75.0	43.0	214 042	10	250 042 T	10
4.25	75.0	43.0	214 0425	10	250 0425 T	10
4.30	80.0	47.0	214 043	10	250 043 T	10
4.40	80.0	47.0	214 044	10	250 044 T	10
4.50	80.0	47.0	214 045	10	250 045 T	10
4.60	80.0	47.0	214 046	10	250 046 T	10
4.70	80.0	47.0	214 047	10	250 047 T	10
4.75	80.0	47.0	214 0475	10	250 0475 T	10
4.80	86.0	52.0	214 048	10	250 048 T	10
4.90	86.0	52.0	214 049	10	250 049 T	10
5.00	86.0	52.0	214 050	10	250 050 T	10
5.10	86.0	52.0	214 051	10	250 051 T	10
5.20	86.0	52.0	214 052	10	250 052 T	10
5.25	86.0	52.0	214 0525	10	250 0525 T	10
5.30	86.0	52.0	214 053	10	250 053 T	10
5.40	93.0	57.0	214 054	10	250 054 T	10
5.50	93.0	57.0	214 055	10	250 055 T	10
5.60	93.0	57.0	214 056	10	250 056 T	10
5.70	93.0	57.0	214 057	10	250 057 T	10
5.75	93.0	57.0	214 0575	10	250 0575 T	10
5.80	93.0	57.0	214 058	10	250 058 T	10
5.90	93.0	57.0	214 059	10	250 059 T	10
6.00	93.0	57.0	214 060	10	250 060 T	10
6.10	101.0	63.0	214 061	10	250 061 T	10
6.20	101.0	63.0	214 062	10	250 062 T	10
6.25	101.0	63.0	214 0625	10	250 0625 T	10
6.30	101.0	63.0	214 063	10	250 063 T	10
6.40	101.0	63.0	214 064	10	250 064 T	10
6.50	101.0	63.0	214 065	10	250 065 T	10
6.60	101.0	63.0	214 066	10	250 066 T	10
6.70	101.0	63.0	214 067	10	250 067 T	10
6.75	101.0	63.0	214 0675	10	250 0675 T	10
6.80	109.0	69.0	214 068	10	250 068 T	10
6.90	109.0	69.0	214 069	10	250 069 T	10
7.00	109.0	69.0	214 070	10	250 070 T	10
7.10	109.0	69.0	214 071	10	250 071 T	10
7.20	109.0	69.0	214 072	10	250 072 T	10
7.25	109.0	69.0	214 0725	10	250 0725 T	10
7.30	109.0	69.0	214 073	10	250 073 T	10
7.40	109.0	69.0	214 074	10	250 074 T	10
7.50	109.0	69.0	214 075	10	250 075 T	10
7.60	117.0	75.0	214 076	10	250 076 T	10
7.70	117.0	75.0	214 077	10	250 077 T	10
7.75	117.0	75.0	214 0775	10	250 0775 T	10
7.80	117.0	75.0	214 078	10	250 078 T	10
7.90	117.0	75.0	214 079	10	250 079 T	10
8.00	117.0	75.0	214 080	10	250 080 T	10
8.10	117.0	75.0	214 081	10	250 081 T	10
8.20	117.0	75.0	214 082	10	250 082 T	10
8.25	117.0	75.0	214 0825	10	250 0825 T	10
8.30	117.0	75.0	214 083	10	250 083 T	10
8.40	117.0	75.0	214 084	10	250 084 T	10
8.50	117.0	75.0	214 085	10	250 085 T	10
8.60	125.0	81.0	214 086	10	250 086 T	10
8.70	125.0	81.0	214 087	10	250 087 T	10
8.75	125.0	81.0	214 0875	10	250 0875 T	10
8.80	125.0	81.0	214 088	10	250 088 T	10
8.90	125.0	81.0	214 089	10	250 089 T	10
9.00	125.0	81.0	214 090	10	250 090 T	10
9.10	125.0	81.0	214 091	10	250 091 T	10
9.20	125.0	81.0	214 092	10	250 092 T	10
9.25	125.0	81.0	214 0925	10	250 0925 T	10
9.30	125.0	81.0	214 093	10	250 093 T	10
9.40	125.0	81.0	214 094	10	250 094 T	10
9.50	125.0	81.0	214 095	10	250 095 T	10
9.60	133.0	87.0	214 096	10	250 096 T	10
9.70	133.0	87.0	214 097	10	250 097 T	10
9.75	133.0	87.0	214 0975	10	250 0975 T	10
9.80	133.0	87.0	214 098	10	250 098 T	10



Ø mm	L1 mm	L2 mm	HSS		HSS TiN	
9.90	133.0	87.0	214 099	10	250 099 T	10
10.00	133.0	87.0	214 100	10	250 100 T	10
10.10	133.0	87.0	214 101	10	250 101 T	10
10.20	133.0	87.0	214 102	10	250 102 T	10
10.30	133.0	87.0	214 103	10	250 103 T	10
10.40	133.0	87.0	214 104	10	250 104 T	10
10.50	133.0	87.0	214 105	5	250 105 T	5
10.60	133.0	87.0	214 106	5	250 106 T	5
10.70	142.0	94.0	214 107	5	250 107 T	5
10.80	142.0	94.0	214 108	5	250 108 T	5
10.90	142.0	94.0	214 109	5	250 109 T	5
11.00	142.0	94.0	214 110	5	250 110 T	5
11.10	142.0	94.0	214 111	5	250 111 T	5
11.20	142.0	94.0	214 112	5	250 112 T	5
11.30	142.0	94.0	214 113	5	250 113 T	5
11.40	142.0	94.0	214 114	5	250 114 T	5
11.50	142.0	94.0	214 115	5	250 115 T	5
11.60	142.0	94.0	214 116	5	250 116 T	5
11.70	142.0	94.0	214 117	5	250 117 T	5
11.80	142.0	94.0	214 118	5	250 118 T	5
11.90	151.0	101.0	214 119	5	250 119 T	5
12.00	151.0	101.0	214 120	5	250 120 T	5
12.10	151.0	101.0	214 121	5	250 121 T	5
12.20	151.0	101.0	214 122	5	250 122 T	5
12.30	151.0	101.0	214 123	5	250 123 T	5
12.40	151.0	101.0	214 124	5	250 124 T	5
12.50	151.0	101.0	214 125	5	250 125 T	5
12.60	151.0	101.0	214 126	5	250 126 T	5
12.70	151.0	101.0	214 127	5	250 127 T	5
12.80	151.0	101.0	214 128	5	250 128 T	5
12.90	151.0	101.0	214 129	5	250 129 T	5
13.00	151.0	101.0	214 130	5	250 130 T	5
13.50	160.0	108.0	214 135	5	250 135 T	5
14.00	160.0	108.0	214 140	5	250 140 T	5
14.50	169.0	114.0	214 145	5	250 145 T	5
15.00	169.0	114.0	214 150	5	250 150 T	5
15.50	178.0	120.0	214 155	5	250 155 T	5
16.00	178.0	120.0	214 160	5	250 160 T	5
16.50	184.0	125.0	214 165	1		
17.00	184.0	125.0	214 170	1		
17.50	191.0	130.0	214 175	1		
18.00	191.0	130.0	214 180	1		
18.50	198.0	135.0	214 185	1		
19.00	198.0	135.0	214 190	1		
19.50	205.0	140.0	214 195	1		
20.00	205.0	140.0	214 201	1		

		HSS
<b>19</b> tfg./pcs.	Spiralbohrer DIN 338 Typ N. HSS Ø 1.0 mm bis 10.0 mm x 0.5 mm steigend	214 214 R0
<b>24</b> tfg./pcs.	Spiralbohrer DIN 338 Typ N. HSS Ø 1.0 mm bis 10.5 mm x 0.5 mm steigend + 3.3 / 4.2 / 6.8 / 10.2 mm	214 216 R0
<b>25</b> tfg./pcs.	Spiralbohrer DIN 338 Typ N. HSS Ø 1.0 mm bis 13.0 mm x 0.5 mm steigend	214 215 R0
<b>41</b> tfg./pcs.	Spiralbohrer DIN 338 Typ N. HSS Ø 6.0 mm bis 10.0 mm x 0.1 mm steigend	214 218 R0
<b>50</b> tfg./pcs.	Spiralbohrer DIN 338 Typ N. HSS Ø 1.0 mm bis 5.9 mm x 0.1 mm steigend	214 217 R0



214 214 R0

		HSS TiN
<b>19</b> tfg./pcs.	Spiralbohrer DIN 338 Typ N. HSS-TiN Ø 1.0 mm bis 10.0 mm x 0.5 mm steigend	250 214 TRO
<b>25</b> tfg./pcs.	Spiralbohrer DIN 338 Typ N. HSS-TiN Ø 1.0 mm bis 13.0 mm x 0.5 mm steigend	250 215 TRO



250 214 TRO



		HSS
<b>91</b> tfg./pcs.	Spiralbohrer-Satz im Werkbankständer Ø 1.0 mm bis 10.0 mm x 0.1 mm steigend	214 223
<b>170</b> tfg./pcs.	Spiralbohrer-Satz im Magazin je 10 Stück Ø 1.0 - 8.0 mm x 0.5 mm steigend je 5 Stück Ø 8.5 - 10.0 mm x 0.5 mm steigend	214 200 RO
<b>570</b> tfg./pcs.	Bohrer-Schrank, bestückt je 50 Stück Ø 1.0 - 2.5 mm x 0.5 mm steigend je 30 Stück Ø 3.0 - 5.5 mm x 0.5 mm steigend je 20 Stück Ø 6.0 - 7.5 mm x 0.5 mm steigend je 10 Stück Ø 8.0 - 13.0 mm x 0.5 mm steigend	214 208



214 223



214 200 RO



214 208  
(Bestückung nicht abgebildet)

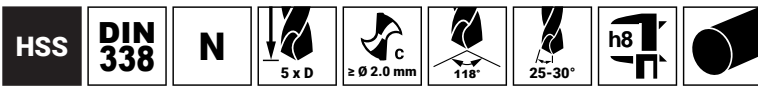

## Spiralbohrer DIN 338 Typ N, HSS – Zollabmessungen



Leistungsstarker, geschliffener Standard-Spiralbohrer aus Schnellarbeitsstahl. Der komplett geschliffene Spiralbohrer verfügt über eine präzise Rundlaufgenauigkeit. Durch den Kreuzanschliff hat dieser Bohrer eine gute Zentrierung und benötigt eine geringe Vorschubkraft.

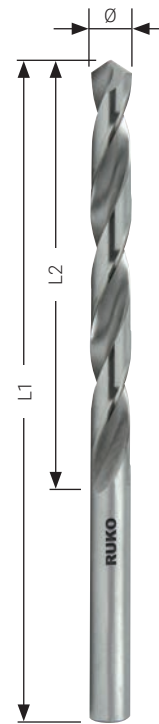

**Inch Size**

Verpackung: Kunststoff

Ø Zoll	Ø mm	L1 Zoll	L2 Zoll	HSS	
1/16	1,59	1 7/8	7/8	214 801	10
5/64	1,98	2	1	214 802	10
3/32	2,38	2 1/4	1 1/4	214 803	10
7/64	2,78	2 5/8	1 1/2	214 804	10
1/8	3,18	2 3/4	1 5/8	214 805	10
9/64	3,57	2 7/8	1 3/4	214 806	10
5/32	3,97	3 1/8	2	214 807	10
11/64	4,37	3 1/4	2 1/8	214 808	10
3/16	4,76	3 1/2	2 5/16	214 809	10
13/64	5,16	3 5/8	2 7/16	214 810	10
7/32	5,56	3 3/4	2 1/2	214 811	10
15/64	5,95	3 7/8	2 5/8	214 812	10
1/4	6,35	4	2 3/4	214 813	10
17/64	6,75	4 1/8	2 7/8	214 814	10
9/32	7,14	4 1/4	2 15/16	214 815	10

Ø Zoll	Ø mm	L1 Zoll	L2 Zoll	HSS	
19/64	7,54	4 3/8	3 1/16	214 816	10
5/16	7,94	4 1/2	3 3/16	214 817	10
21/64	8,33	4 5/8	3 5/16	214 818	10
11/32	8,73	4 3/4	3 7/16	214 819	10
23/64	9,13	4 7/8	3 1/2	214 820	10
3/8	9,53	5	3 5/8	214 821	10
25/64	9,92	5 1/8	3 3/4	214 822	10
13/32	10,32	5 1/4	3 7/8	214 823	10
27/64	10,72	5 3/8	3 15/16	214 824	5
7/16	11,11	5 1/2	4 1/16	214 825	5
29/64	11,51	5 5/8	4 3/16	214 826	5
15/32	11,91	5 3/4	4 5/16	214 827	5
31/64	12,30	5 7/8	4 3/8	214 828	5
1/2	12,70	6	4 1/2	214 829	5

		HSS
<b>21</b> Stk./pcs.	Spiralbohrer-Satz DIN 338 Typ N Ø 1/16" bis 3/8" x 1/64" steigend	214 850 RO
<b>29</b> Stk./pcs.	Spiralbohrer-Satz DIN 338 Typ N Ø 1/16" bis 1/2" x 1/64" steigend	214 851 RO



214 850 RO

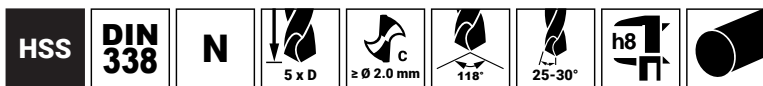

## Spiralbohrer DIN 338 Typ N, HSS TiN – Zollabmessungen



Leistungsstarker, geschliffener Standard-Spiralbohrer aus Schnellarbeitsstahl. Der komplett geschliffene Spiralbohrer verfügt über eine präzise Rundlaufgenauigkeit. Durch den Kreuzanschliff hat dieser Bohrer eine gute Zentrierung und benötigt eine geringe Vorschubkraft.

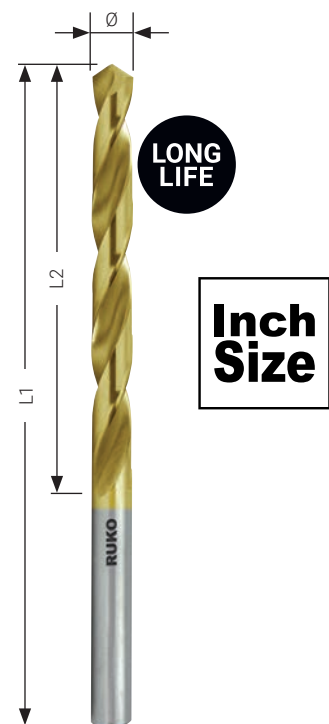

**Inch Size**

Verpackung: Kunststoff

Ø Zoll	Ø mm	L1 Zoll	L2 Zoll	HSS TiN	
1/16	1,59	1 7/8	7/8	250 801 T	10
5/64	1,98	2	1	250 802 T	10
3/32	2,38	2 1/4	1 1/4	250 803 T	10
7/64	2,78	2 5/8	1 1/2	250 804 T	10
1/8	3,18	2 3/4	1 5/8	250 805 T	10
9/64	3,57	2 7/8	1 3/4	250 806 T	10
5/32	3,97	3 1/8	2	250 807 T	10
11/64	4,37	3 1/4	2 1/8	250 808 T	10
3/16	4,76	3 1/2	2 5/16	250 809 T	10
13/64	5,16	3 5/8	2 7/16	250 810 T	10
7/32	5,56	3 3/4	2 1/2	250 811 T	10
15/64	5,95	3 7/8	2 5/8	250 812 T	10
1/4	6,35	4	2 3/4	250 813 T	10
17/64	6,75	4 1/8	2 7/8	250 814 T	10
9/32	7,14	4 1/4	2 15/16	250 815 T	10

Ø Zoll	Ø mm	L1 Zoll	L2 Zoll	HSS TiN	
19/64	7,54	4 3/8	3 1/16	250 816 T	10
5/16	7,94	4 1/2	3 3/16	250 817 T	10
21/64	8,33	4 5/8	3 5/16	250 818 T	10
11/32	8,73	4 3/4	3 7/16	250 819 T	10
23/64	9,13	4 7/8	3 1/2	250 820 T	10
3/8	9,53	5	3 5/8	250 821 T	10
25/64	9,92	5 1/8	3 3/4	250 822 T	10
13/32	10,32	5 1/4	3 7/8	250 823 T	10
27/64	10,72	5 3/8	3 15/16	250 824 T	5
7/16	11,11	5 1/2	4 1/16	250 825 T	5
29/64	11,51	5 5/8	4 3/16	250 826 T	5
15/32	11,91	5 3/4	4 5/16	250 827 T	5
31/64	12,30	5 7/8	4 3/8	250 828 T	5
1/2	12,70	6	4 1/2	250 829 T	5

		HSS TiN
<b>21</b> tlg./pcs.	Spiralbohrer-Satz DIN 338 Typ N, HSS-TiN Ø 1/16" bis 3/8" x 1/64" steigend	250 850 TRO
<b>29</b> tlg./pcs.	Spiralbohrer-Satz DIN 338 Typ N, HSS-TiN Ø 1/16" bis 1/2" x 1/64" steigend	250 851 TRO



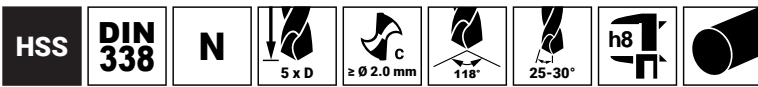

## Spiralbohrer DIN 338 Typ N, HSS-G mit TiN-Spitzenbeschichtung



Leistungsstarker, geschliffener Standard-Spiralbohrer aus Schnellarbeitsstahl. Der komplett geschliffene Spiralbohrer verfügt über eine präzise Rundlaufgenauigkeit. Durch den Kreuzanschliff hat dieser Bohrer eine gute Zentrierung und benötigt eine geringe Vorschubkraft.

Die Titan-Nitrit-Beschichtung ist eine universal einsetzbare Standardschicht. Sie bietet eine um 300 bis 400 % höhere Standzeit im Vergleich zu unbeschichteten Werkzeugen. Kühlung ist empfehlenswert.

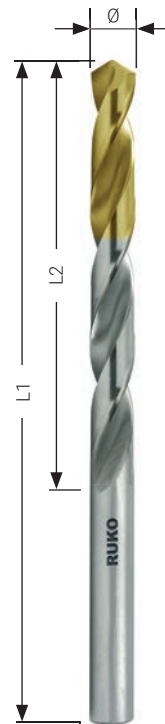

Verpackung: Kunststoff

Ø mm	L1 mm	L2 mm	HSS TiN	
1,00	34,0	12,0	2501 010 T	10
1,50	40,0	18,0	2501 015 T	10
1,60	43,0	20,0	2501 016 T	10
2,00	49,0	24,0	2501 020 T	10
2,10	49,0	24,0	2501 021 T	10
2,50	57,0	30,0	2501 025 T	10
3,00	61,0	33,0	2501 030 T	10
3,30	65,0	36,0	2501 033 T	10
3,50	70,0	39,0	2501 035 T	10
4,00	75,0	43,0	2501 040 T	10
4,20	75,0	43,0	2501 042 T	10
4,50	80,0	47,0	2501 045 T	10
5,00	86,0	52,0	2501 050 T	10
5,50	93,0	57,0	2501 055 T	10
6,00	93,0	57,0	2501 060 T	10
6,50	101,0	63,0	2501 065 T	10

Ø mm	L1 mm	L2 mm	HSS TiN	
6,80	109,0	69,0	2501 068 T	10
7,00	109,0	69,0	2501 070 T	10
7,50	109,0	69,0	2501 075 T	10
8,00	117,0	75,0	2501 080 T	10
8,50	117,0	75,0	2501 085 T	10
9,00	125,0	81,0	2501 090 T	10
9,50	125,0	81,0	2501 095 T	10
10,00	133,0	87,0	2501 100 T	10
10,20	133,0	87,0	2501 102 T	10
10,50	133,0	87,0	2501 105 T	5
11,00	142,0	94,0	2501 110 T	5
11,50	142,0	94,0	2501 115 T	5
12,00	151,0	101,0	2501 120 T	5
12,50	151,0	101,0	2501 125 T	5
13,00	151,0	101,0	2501 130 T	5

		HSS TiN
<b>19</b> tfg./pcs.	Spiralbohrer-Satz DIN 338 Typ N Ø 1,0 mm bis 10,0 mm x 0,5 mm steigend	2501 214 TRO
<b>25</b> tfg./pcs.	Spiralbohrer-Satz DIN 338 Typ N Ø 1,0 mm bis 13,0 mm x 0,5 mm steigend	2501 215 TRO



2501 214 TRO

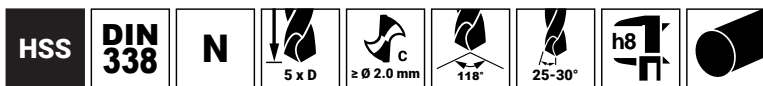

## Spiralbohrer DIN 338 Typ N, HSS – linksschneidend



Leistungsstarker, geschliffener Spiralbohrer aus Schnellarbeitsstahl. Der komplett geschliffene Spiralbohrer verfügt über eine präzise Rundlaufgenauigkeit.



### Anwendungstipp

Dieser linksschneidende Spiralbohrer wurde speziell für den portablen Einsatz in Bohrmaschinen und Akku-Bohrschraubern entwickelt. Zum Ausbohren von abgebrochenen Schrauben und Bolzen.

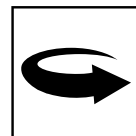
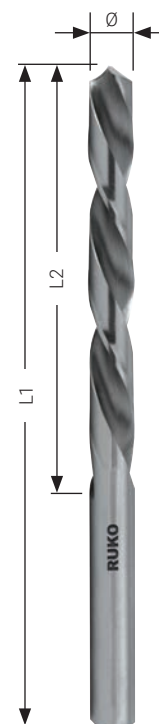

Verpackung: Kunststoff

Ø mm	L1 mm	L2 mm	HSS	
1.00	34.0	12.0	214 010 Li	10
1.50	40.0	18.0	214 015 Li	10
2.00	49.0	24.0	214 020 Li	10
2.50	57.0	30.0	214 025 Li	10
3.00	61.0	33.0	214 030 Li	10
3.20	65.0	36.0	214 032 Li	10
3.50	70.0	39.0	214 035 Li	10
4.00	75.0	43.0	214 040 Li	10
4.20	75.0	43.0	214 042 Li	10
4.50	80.0	47.0	214 045 Li	10
4.80	86.0	52.0	214 048 Li	10
5.00	86.0	52.0	214 050 Li	10
5.50	93.0	57.0	214 055 Li	10
6.00	93.0	57.0	214 060 Li	10

Ø mm	L1 mm	L2 mm	HSS	
6.50	101.0	63.0	214 065 Li	10
7.00	109.0	69.0	214 070 Li	10
7.50	109.0	69.0	214 075 Li	10
8.00	117.0	75.0	214 080 Li	10
8.50	117.0	75.0	214 085 Li	10
9.00	125.0	81.0	214 090 Li	10
9.50	125.0	81.0	214 095 Li	10
10.00	133.0	87.0	214 100 Li	10
10.50	133.0	87.0	214 105 Li	5
11.00	142.0	94.0	214 110 Li	5
11.50	142.0	94.0	214 115 Li	5
12.00	151.0	101.0	214 120 Li	5
12.50	151.0	101.0	214 125 Li	5
13.00	151.0	101.0	214 130 Li	5

		HSS
<b>19</b> tlg./pcs.	Spiralbohrer-Satz DIN 338 Typ N Ø 1.0 mm bis 10.0 mm x 0.5 mm steigend	214 214 LiRO
<b>25</b> tlg./pcs.	Spiralbohrer-Satz DIN 338 Typ N Ø 1.0 mm bis 13.0 mm x 0.5 mm steigend	214 215 LiRO



214 214 LiRO



## Spiralbohrer DIN 338 Typ N, HSS-R



Leistungsstarker, rollgewalzter und dampfbehandelter Spiralbohrer aus Schnellarbeitsstahl. Durch das Herstellungsverfahren (keine Gefügeunterbrechung) wird der Werkstoff verfestigt und dadurch elastischer. Damit bietet er eine erhöhte Bruchsicherheit und ist für Handbohrmaschinen geeignet.





Verpackung: Kunststoff

Ø mm	L1 mm	L2 mm	HSS-R	
0.30	19.0	3.0	201 003	10
0.40	20.0	5.0	201 004	10
0.50	22.0	6.0	201 005	10
0.60	24.0	7.0	201 006	10
0.70	28.0	9.0	201 007	10
0.80	30.0	10.0	201 008	10
0.90	32.0	11.0	201 009	10
1.00	34.0	12.0	201 010	10
1.10	36.0	14.0	201 011	10
1.20	38.0	16.0	201 012	10
1.25	38.0	16.0	201 0125	10
1.30	38.0	16.0	201 013	10
1.40	40.0	18.0	201 014	10
1.50	40.0	18.0	201 015	10
1.60	43.0	20.0	201 016	10
1.70	43.0	20.0	201 017	10
1.75	46.0	20.0	201 0175	10
1.80	46.0	22.0	201 018	10
1.90	46.0	22.0	201 019	10
2.00	49.0	24.0	201 020	10
2.10	49.0	24.0	201 021	10
2.20	53.0	27.0	201 022	10
2.25	53.0	27.0	201 0225	10
2.30	53.0	27.0	201 023	10
2.40	57.0	30.0	201 024	10
2.50	57.0	30.0	201 025	10
2.60	57.0	30.0	201 026	10
2.70	61.0	33.0	201 027	10
2.75	61.0	33.0	201 0275	10
2.80	61.0	33.0	201 028	10
2.90	61.0	33.0	201 029	10
3.00	61.0	33.0	201 030	10
3.10	65.0	36.0	201 031	10
3.20	65.0	36.0	201 032	10
3.25	65.0	36.0	201 0325	10
3.30	65.0	36.0	201 033	10
3.40	70.0	39.0	201 034	10
3.50	70.0	39.0	201 035	10
3.60	70.0	39.0	201 036	10
3.70	70.0	39.0	201 037	10

Ø mm	L1 mm	L2 mm	HSS-R	
3.75	70.0	39.0	201 0375	10
3.80	75.0	43.0	201 038	10
3.90	75.0	43.0	201 039	10
4.00	75.0	43.0	201 040	10
4.10	75.0	43.0	201 041	10
4.20	75.0	43.0	201 042	10
4.25	75.0	43.0	201 0425	10
4.30	80.0	47.0	201 043	10
4.40	80.0	47.0	201 044	10
4.50	80.0	47.0	201 045	10
4.60	80.0	47.0	201 046	10
4.70	80.0	47.0	201 047	10
4.75	80.0	47.0	201 0475	10
4.80	86.0	52.0	201 048	10
4.90	86.0	52.0	201 049	10
5.00	86.0	52.0	201 050	10
5.10	86.0	52.0	201 051	10
5.20	86.0	52.0	201 052	10
5.25	86.0	52.0	201 0525	10
5.30	86.0	52.0	201 053	10
5.40	93.0	57.0	201 054	10
5.50	93.0	57.0	201 055	10
5.60	93.0	57.0	201 056	10
5.70	93.0	57.0	201 057	10
5.75	93.0	57.0	201 0575	10
5.80	93.0	57.0	201 058	10
5.90	93.0	57.0	201 059	10
6.00	93.0	57.0	201 060	10
6.10	101.0	63.0	201 061	10
6.20	101.0	63.0	201 062	10
6.25	101.0	63.0	201 0625	10
6.30	101.0	63.0	201 063	10
6.40	101.0	63.0	201 064	10
6.50	101.0	63.0	201 065	10
6.60	101.0	63.0	201 066	10
6.70	101.0	63.0	201 067	10
6.75	101.0	63.0	201 0675	10
6.80	109.0	69.0	201 068	10
6.90	109.0	69.0	201 069	10
7.00	109.0	69.0	201 070	10



Ø mm	L1 mm	L2 mm	HSS-R	
7.10	109.0	69.0	201 071	10
7.20	109.0	69.0	201 072	10
7.25	109.0	69.0	201 0725	10
7.30	109.0	69.0	201 073	10
7.40	109.0	69.0	201 074	10
7.50	109.0	69.0	201 075	10
7.60	117.0	75.0	201 076	10
7.70	117.0	75.0	201 077	10
7.75	117.0	75.0	201 0775	10
7.80	117.0	75.0	201 078	10
7.90	117.0	75.0	201 079	10
8.00	117.0	75.0	201 080	10
8.10	117.0	75.0	201 081	10
8.20	117.0	75.0	201 082	10
8.25	117.0	75.0	201 0825	10
8.30	117.0	75.0	201 083	10
8.40	117.0	75.0	201 084	10
8.50	117.0	75.0	201 085	10
8.60	125.0	81.0	201 086	10
8.70	125.0	81.0	201 087	10
8.75	125.0	81.0	201 0875	10
8.80	125.0	81.0	201 088	10
8.90	125.0	81.0	201 089	10
9.00	125.0	81.0	201 090	10
9.10	125.0	81.0	201 091	10
9.20	125.0	81.0	201 092	10
9.25	125.0	81.0	201 0925	10
9.30	125.0	81.0	201 093	10
9.40	125.0	81.0	201 094	10
9.50	125.0	81.0	201 095	10
9.60	133.0	87.0	201 096	10
9.70	133.0	87.0	201 097	10
9.75	133.0	87.0	201 0975	10
9.80	133.0	87.0	201 098	10
9.90	133.0	87.0	201 099	10
10.00	133.0	87.0	201 100	10
10.10	133.0	87.0	201 101	10
10.20	133.0	87.0	201 102	10
10.30	133.0	87.0	201 103	10
10.40	133.0	87.0	201 104	10

Ø mm	L1 mm	L2 mm	HSS-R	
10.50	133.0	87.0	201 105	5
10.60	133.0	87.0	201 106	5
10.70	142.0	94.0	201 107	5
10.80	142.0	94.0	201 108	5
10.90	142.0	94.0	201 109	5
11.00	142.0	94.0	201 110	5
11.10	142.0	94.0	201 111	5
11.20	142.0	94.0	201 112	5
11.30	142.0	94.0	201 113	5
11.40	142.0	94.0	201 114	5
11.50	142.0	94.0	201 115	5
11.60	142.0	94.0	201 116	5
11.70	142.0	94.0	201 117	5
11.80	142.0	94.0	201 118	5
11.90	151.0	101.0	201 119	5
12.00	151.0	101.0	201 120	5
12.10	151.0	101.0	201 121	5
12.20	151.0	101.0	201 122	5
12.30	151.0	101.0	201 123	5
12.40	151.0	101.0	201 124	5
12.50	151.0	101.0	201 125	5
12.60	151.0	101.0	201 126	5
12.70	151.0	101.0	201 127	5
12.80	151.0	101.0	201 128	5
12.90	151.0	101.0	201 129	5
13.00	151.0	101.0	201 130	5
13.50	160.0	108.0	201 135	5
14.00	160.0	108.0	201 140	5
14.50	169.0	114.0	201 145	5
15.00	169.0	114.0	201 150	5
15.50	178.0	120.0	201 155	5
16.00	178.0	120.0	201 160	5
16.50	184.0	125.0	201 165	1
17.00	184.0	125.0	201 170	1
17.50	191.0	130.0	201 175	1
18.00	191.0	130.0	201 180	1
18.50	198.0	135.0	201 185	1
19.00	198.0	135.0	201 190	1
19.50	205.0	140.0	201 195	1
20.00	205.0	140.0	201 200	1



		HSS-R
<b>19</b> tfg./pcs.	Spiralbohrer DIN 338 Typ N. HSS-R Ø 1.0 mm bis 10.0 mm x 0.5 mm steigend	205 212 RO
<b>24</b> tfg./pcs.	Spiralbohrer DIN 338 Typ N. HSS-R Ø 1.0 mm bis 10.5 mm x 0.5 mm steigend + 3.3 / 4.2 / 6.8 / 10.2 mm	205 216 RO
<b>25</b> tfg./pcs.	Spiralbohrer DIN 338 Typ N. HSS-R Ø 1.0 mm bis 13.0 mm x 0.5 mm steigend	205 213 RO
<b>41</b> tfg./pcs.	Spiralbohrer DIN 338 Typ N. HSS-R Ø 6.0 mm bis 10.0 mm x 0.1 mm steigend	205 218 RO
<b>50</b> tfg./pcs.	Spiralbohrer DIN 338 Typ N. HSS-R Ø 1.0 mm bis 5.9 mm x 0.1 mm steigend	205 217 RO



		HSS-R
<b>91</b> tfg./pcs.	Spiralbohrer-Satz im Werkbankständer Ø 1.0 mm bis 10.0 mm x 0.1 mm steigend	205 223
<b>570</b> tfg./pcs.	Bohrer-Schrank, bestückt je 50 Stück Ø 1.0 - 2.5 mm x 0.5 mm steigend je 30 Stück Ø 3.0 - 5.5 mm x 0.5 mm steigend je 20 Stück Ø 6.0 - 7.5 mm x 0.5 mm steigend je 10 Stück Ø 8.0 - 13.0 mm x 0.5 mm steigend	205 208
	Bohrer-Schrank leer Maße: H1: 23.0 cm. L1: 37.0 cm. T1: 9.5 cm. T2: 20.0 cm Ø 1.0 mm bis 13.0 mm x 0.5 mm steigend	205 208 L
	Bohrer-Schrank leer Maße: H1: 46.5 cm. L1: 39.0 cm. T1: 9.5 cm. T2: 20.0 cm Ø 1.0 mm bis 10.0 mm x 0.1 mm steigend Ø 10.5 mm bis 13.0 mm x 0.5 mm steigend	205 2081 L





## Spiralbohrer DIN 338 Typ N mit abgesetztem Schaft

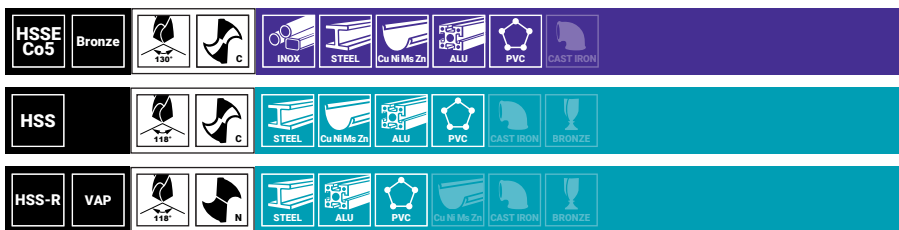

Ideal geeignet zum Bohren größerer Bohrdurchmesser.  
Geeignet für alle gängigen Bohrmaschinen mit einem Spannfutter bis 13,0 mm.



Ø1 mm	L1 mm	Ø2 mm	L2 mm	HSSE-Co 5		HSS		HSS-R	
10.50	133.0	10.0	30.0	200 5 105	1	200 4 105	1	200 105	1
11.00	142.0	10.0	30.0	200 5 110	1	200 4 110	1	200 110	1
11.50	142.0	10.0	30.0	200 5 115	1	200 4 115	1	200 115	1
12.00	151.0	10.0	30.0	200 5 120	1	200 4 120	1	200 120	1
12.50	151.0	10.0	30.0	200 5 125	1	200 4 125	1	200 125	1
13.00	151.0	10.0	30.0	200 5 130	1	200 4 130	1	200 130	1
13.50	160.0	10.0	30.0	200 5 135	1	200 4 135	1	200 135	1
14.00	160.0	10.0	30.0	200 5 140	1	200 4 140	1	200 140	1
14.50	169.0	10.0	30.0	200 5 145	1	200 4 145	1	200 145	1
15.00	169.0	10.0	30.0	200 5 150	1	200 4 150	1	200 150	1
15.50	178.0	10.0	30.0	200 5 155	1	200 4 155	1	200 155	1
16.00	178.0	10.0	30.0	200 5 160	1	200 4 160	1	200 160	1
16.50	184.0	13.0	35.0	200 5 165	1	200 4 165	1	200 165	1
17.00	184.0	13.0	35.0	200 5 170	1	200 4 170	1	200 170	1
17.50	191.0	13.0	35.0	200 5 175	1	200 4 175	1	200 175	1
18.00	191.0	13.0	35.0	200 5 180	1	200 4 180	1	200 180	1
18.50	198.0	13.0	35.0	200 5 185	1	200 4 185	1	200 185	1
19.00	198.0	13.0	35.0	200 5 190	1	200 4 190	1	200 190	1
19.50	205.0	13.0	35.0	200 5 195	1	200 4 195	1	200 195	1
20.00	205.0	13.0	35.0	200 5 200	1	200 4 200	1	200 200	1
22.00	205.0	13.0	35.0					200 220	1
24.00	205.0	13.0	35.0					200 240	1
25.00	205.0	13.0	35.0					200 250	1

		HSS
<b>10</b> Stk./Pcs.	Spiralbohrer-Satz DIN 338 Typ N, HSS mit abgesetztem Schaft Ø 14.0   15.0   15.5   16.0   17.0   17.5   18.0   19.0   19.5   20.0 mm	200 4 201



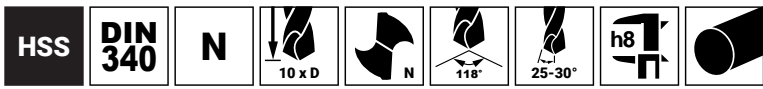

## Spiralbohrer DIN 340 Typ N, HSS-G



Leistungsstarker, geschliffener Standard-Spiralbohrer aus Schnellarbeitsstahl. Der komplett geschliffene Spiralbohrer verfügt über eine präzise Rundlaufgenauigkeit.

Verpackung: Kunststoff

Ø mm	L1 mm	L2 mm	HSS	
2.50	95.0	62.0	203 025	10
3.00	100.0	66.0	203 030	10
3.30	106.0	69.0	203 033	10
3.50	112.0	73.0	203 035	10
4.00	119.0	78.0	203 040	10
4.20	119.0	78.0	203 042	10
4.50	126.0	82.0	203 045	10
5.00	132.0	87.0	203 050	10
5.50	139.0	91.0	203 055	10
6.00	139.0	91.0	203 060	10
6.50	148.0	97.0	203 065	10
6.80	156.0	102.0	203 068	10
7.00	156.0	102.0	203 070	10
7.50	156.0	102.0	203 075	10
7.80	165.0	109.0	203 078	10
8.00	165.0	109.0	203 080	10
8.50	165.0	109.0	203 085	10
9.00	175.0	115.0	203 090	10
9.50	175.0	115.0	203 095	10
10.00	184.0	121.0	203 100	10
10.50	184.0	121.0	203 105	5
11.00	195.0	128.0	203 110	5
11.50	195.0	128.0	203 115	5
12.00	205.0	134.0	203 120	5
12.50	205.0	134.0	203 125	5
13.00	205.0	134.0	203 130	5

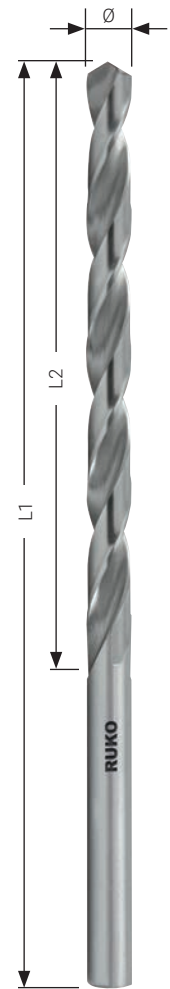



## Spiralbohrer DIN 1869 TL 3000, HSS – extra lang



Stabiler Spezialbohrer zum Bohren extrem tiefer Löcher unter erschwerten Bohrbedingungen, z.B. bei schlechter Spanabfuhr.

Geeignet für tiefe Bohrarbeiten in allgemein gängigen Werkstoffen. Hohe Bruchsicherheit. Bei Tieflochbohrungen sind kleinere Vorschübe und häufigere Spanentleerungen notwendig.

Verpackung: Kunststoff

Ø mm	L1 mm	L2 mm	HSS	
2.00	125.0	85.0	254 020	1
2.50	140.0	95.0	254 025	1
3.00	150.0	100.0	254 030	1
3.20	155.0	105.0	254 032	1
3.30	155.0	105.0	254 033	1
3.50	165.0	115.0	254 035	1
4.00	175.0	120.0	254 040	1
4.20	175.0	120.0	254 042	1
4.50	185.0	125.0	254 045	1
5.00	195.0	135.0	254 050	1
5.50	205.0	140.0	254 055	1
6.00	205.0	140.0	254 060	1
6.50	215.0	150.0	254 065	1
7.00	225.0	155.0	254 070	1
7.50	225.0	155.0	254 075	1
8.00	240.0	165.0	254 080	1
8.50	240.0	165.0	254 085	1
9.00	250.0	175.0	254 090	1
9.50	250.0	175.0	254 095	1
10.00	265.0	185.0	254 100	1
10.50	265.0	185.0	254 105	1
11.00	280.0	195.0	254 110	1
11.50	280.0	195.0	254 115	1
12.00	295.0	205.0	254 120	1
12.50	295.0	205.0	254 125	1
13.00	295.0	205.0	254 130	1

Ø mm	L1 mm	L2 mm	HSS	
3.00	190.0	130.0	255 030	1
3.20	200.0	135.0	255 032	1
3.30	200.0	135.0	255 033	1
3.50	210.0	145.0	255 035	1
4.00	220.0	150.0	255 040	1
4.20	220.0	150.0	255 042	1
4.50	235.0	160.0	255 045	1
5.00	245.0	170.0	255 050	1
5.50	260.0	180.0	255 055	1
6.00	260.0	180.0	255 060	1
6.50	275.0	190.0	255 065	1
7.00	290.0	200.0	255 070	1
7.50	290.0	200.0	255 075	1
8.00	305.0	210.0	255 080	1
8.50	305.0	210.0	255 085	1
9.00	320.0	220.0	255 090	1
9.50	320.0	220.0	255 095	1
10.00	340.0	235.0	255 100	1
10.50	340.0	235.0	255 105	1
11.00	365.0	250.0	255 110	1
11.50	365.0	250.0	255 115	1
12.00	375.0	260.0	255 120	1
12.50	375.0	260.0	255 125	1
13.00	375.0	260.0	255 130	1

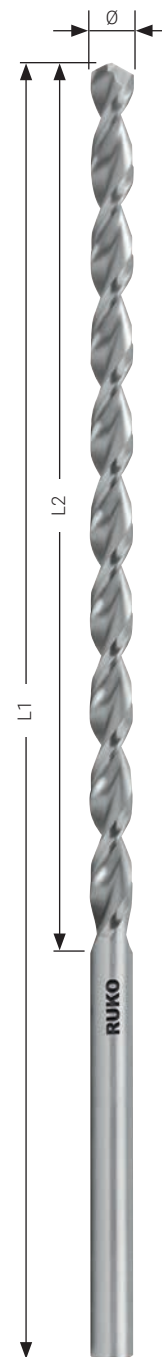



## Spiralbohrer DIN 345 Typ N, HSS und HSSE-Co 5

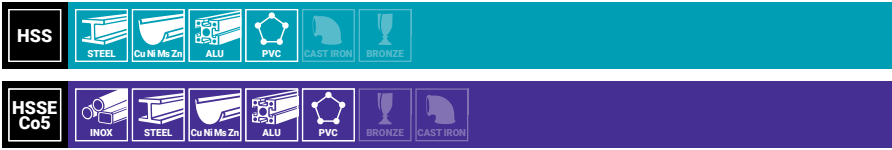

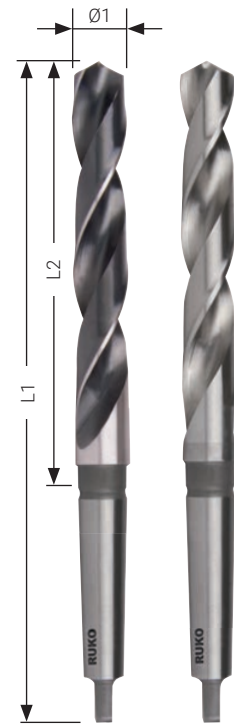

Leistungsstarker Standardbohrer mit Morsekegel.  
Zum Bohren von Stahl, Stahlguss und Gusseisen, legiert und unlegiert. Hohe Bruchsicherheit.



Verpackung: Kunststoff

Ø mm	L1 mm	L2 mm	Morsekegel	HSSE-Co 5		HSS	
10.00	168.0	87.0	1	204 100 E	1	204 100	1
10.50	168.0	87.0	1	204 105 E	1	204 105	1
11.00	175.0	94.0	1	204 110 E	1	204 110	1
11.50	175.0	94.0	1	204 115 E	1	204 115	1
12.00	182.0	101.0	1	204 120 E	1	204 120	1
12.50	182.0	101.0	1	204 125 E	1	204 125	1
13.00	182.0	101.0	1	204 130 E	1	204 130	1
13.50	189.0	108.0	1	204 135 E	1	204 135	1
14.00	189.0	108.0	1	204 140 E	1	204 140	1
14.50	212.0	114.0	2	204 145 E	1	204 145	1
15.00	212.0	114.0	2	204 150 E	1	204 150	1
15.50	218.0	120.0	2	204 155 E	1	204 155	1
16.00	218.0	120.0	2	204 160 E	1	204 160	1
16.50	223.0	125.0	2	204 165 E	1	204 165	1
17.00	223.0	125.0	2	204 170 E	1	204 170	1
17.50	228.0	130.0	2	204 175 E	1	204 175	1
18.00	228.0	130.0	2	204 180 E	1	204 180	1
18.50	233.0	135.0	2	204 185 E	1	204 185	1
19.00	233.0	135.0	2	204 190 E	1	204 190	1
19.50	238.0	140.0	2	204 195 E	1	204 195	1
20.00	238.0	140.0	2	204 200 E	1	204 200	1
20.50	243.0	145.0	2	204 205 E	1	204 205	1
21.00	243.0	145.0	2	204 210 E	1	204 210	1
21.50	248.0	150.0	2	204 215 E	1	204 215	1
22.00	248.0	150.0	2	204 220 E	1	204 220	1
22.50	253.0	155.0	2	204 225 E	1	204 225	1
23.00	253.0	155.0	2	204 230 E	1	204 230	1
23.50	276.0	155.0	3	204 235 E	1	204 235	1
24.00	281.0	160.0	3	204 240 E	1	204 240	1
24.50	281.0	160.0	3	204 245 E	1	204 245	1
25.00	281.0	160.0	3	204 250 E	1	204 250	1
25.50	286.0	165.0	3	204 255 E	1	204 255	1
26.00	286.0	165.0	3	204 260 E	1	204 260	1
26.50	286.0	165.0	3	204 265 E	1	204 265	1
27.00	291.0	170.0	3	204 270 E	1	204 270	1
27.50	291.0	170.0	3	204 275 E	1	204 275	1
28.00	291.0	170.0	3	204 280 E	1	204 280	1
28.50	296.0	175.0	3	204 285 E	1	204 285	1
29.00	296.0	175.0	3	204 290 E	1	204 290	1
29.50	296.0	175.0	3	204 295 E	1	204 295	1
30.00	296.0	175.0	3	204 300 E	1	204 300	1

Ø mm	L1 mm	L2 mm	Morse-kegel	HSSE-Co 5		HSS	
30.50	301.0	180.0	3	-		204 305	1
31.00	301.0	180.0	3	-		204 310	1
31.50	301.0	180.0	3	-		204 315	1
32.00	334.0	185.0	4	-		204 320	1
32.50	334.0	185.0	4	-		204 325	1
33.00	334.0	185.0	4	-		204 330	1
33.50	334.0	185.0	4	-		204 335	1
34.00	339.0	190.0	4	-		204 340	1
34.50	339.0	190.0	4	-		204 345	1
35.00	339.0	190.0	4	-		204 350	1
35.50	339.0	190.0	4	-		204 355	1
36.00	344.0	195.0	4	-		204 360	1
36.50	344.0	195.0	4	-		204 365	1
37.00	344.0	195.0	4	-		204 370	1
37.50	344.0	195.0	4	-		204 375	1
38.00	349.0	200.0	4	-		204 380	1
38.50	349.0	200.0	4	-		204 385	1
39.00	349.0	200.0	4	-		204 390	1
39.50	349.0	200.0	4	-		204 395	1
40.00	349.0	200.0	4	-		204 400	1
40.50	354.0	205.0	4	-		204 405	1
41.00	354.0	205.0	4	-		204 410	1
41.50	354.0	205.0	4	-		204 415	1
42.00	354.0	205.0	4	-		204 420	1
42.50	354.0	205.0	4	-		204 425	1
43.00	359.0	210.0	4	-		204 430	1
43.50	359.0	210.0	4	-		204 435	1
44.00	359.0	210.0	4	-		204 440	1
44.50	359.0	210.0	4	-		204 445	1
45.00	359.0	210.0	4	-		204 450	1
45.50	364.0	215.0	4	-		204 455	1
46.00	364.0	215.0	4	-		204 460	1
46.50	364.0	215.0	4	-		204 465	1
47.00	364.0	215.0	4	-		204 470	1
47.50	364.0	215.0	4	-		204 475	1
48.00	369.0	220.0	4	-		204 480	1
48.50	369.0	220.0	4	-		204 485	1
49.00	369.0	220.0	4	-		204 490	1
49.50	369.0	220.0	4	-		204 495	1
50.00	369.0	220.0	4	-		204 500	1
51.00	412.0	225.0	5	-		204 510	1
52.00	412.0	225.0	5	-		204 520	1
53.00	412.0	225.0	5	-		204 530	1
54.00	417.0	230.0	5	-		204 540	1
55.00	417.0	230.0	5	-		204 550	1
56.00	417.0	230.0	5	-		204 560	1
57.00	422.0	235.0	5	-		204 570	1
58.00	422.0	235.0	5	-		204 580	1
59.00	422.0	235.0	5	-		204 590	1
60.00	422.0	235.0	5	-		204 600	1



## Spiralbohrer DIN 1897 Typ N, HSSE-Co 5 – kurz

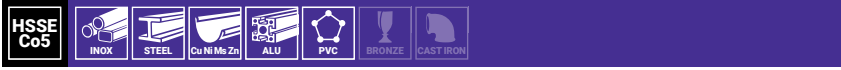

Kurzer und stabiler Spiralbohrer mit ausgeprägter Warmhärtebeständigkeit. Ideal geeignet für Montagearbeiten in dünnwandigen Materialien wie Blechen, Flach- und Profileisen im Karosseriebau. Einsatz in Handbohrmaschinen, auf Automaten und Revolverbänken.



Verpackung: Kunststoff

Ø mm	L1 mm	L2 mm	HSSE-Co 5	
2.00	38.0	12.0	202 020 E	10
2.50	43.0	14.0	202 025 E	10
3.00	46.0	16.0	202 030 E	10
3.10	49.0	18.0	202 031 E	10
3.20	49.0	18.0	202 032 E	10
3.25	49.0	18.0	202 0325 E	10
3.30	49.0	18.0	202 033 E	10
3.50	52.0	20.0	202 035 E	10
3.60	52.0	20.0	202 036 E	10
4.00	55.0	22.0	202 040 E	10
4.10	55.0	22.0	202 041 E	10
4.20	55.0	22.0	202 042 E	10
4.50	58.0	24.0	202 045 E	10
4.80	62.0	26.0	202 048 E	10
4.90	62.0	26.0	202 049 E	10
5.00	62.0	26.0	202 050 E	10
5.10	62.0	26.0	202 051 E	10
5.20	62.0	26.0	202 052 E	10
5.50	66.0	28.0	202 055 E	10
5.70	66.0	28.0	202 057 E	10
5.80	66.0	28.0	202 058 E	10
5.90	66.0	28.0	202 059 E	10
6.00	66.0	28.0	202 060 E	10
6.30	70.0	31.0	202 063 E	10
6.50	70.0	31.0	202 065 E	10
6.80	74.0	34.0	202 068 E	10
7.00	74.0	34.0	202 070 E	10
7.50	74.0	34.0	202 075 E	10
8.00	79.0	37.0	202 080 E	10
8.50	79.0	37.0	202 085 E	10
9.00	84.0	40.0	202 090 E	10
9.50	84.0	40.0	202 095 E	10
10.00	89.0	43.0	202 100 E	10
10.50	89.0	43.0	202 105 E	5
11.00	95.0	47.0	202 110 E	5
11.50	95.0	47.0	202 115 E	5
12.00	102.0	51.0	202 120 E	5
12.50	102.0	51.0	202 125 E	5
13.00	102.0	51.0	202 130 E	5

Auf Anfrage sind auch Sondergrößen lieferbar.





## Spiralbohrer DIN 1897 Typ N, HSS – kurz

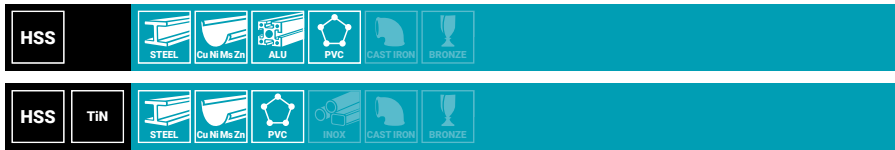

Kurzer und stabiler Spiralbohrer mit ausgeprägter Warmhärtebeständigkeit. Ideal geeignet für Montagearbeiten in dünnwandigen Materialien wie z. B. Blechen, Flach- und Profilleisen im Karosseriebau. Einsatz in Handbohrmaschinen, auf Automaten und Revolverbänken.

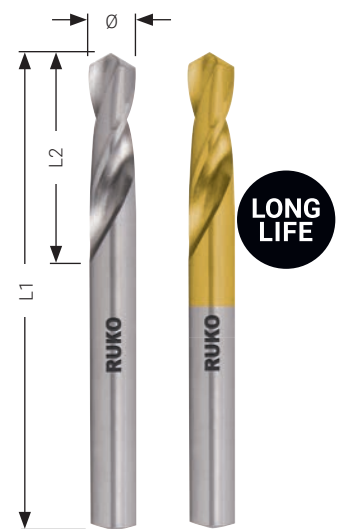

Verpackung: Kunststoff

Ø mm	L1 mm	L2 mm	HSS		HSS TIN	
2.00	38.0	12.0	202 020	10	202 020 T	10
2.50	43.0	14.0	202 025	10	202 025 T	10
3.00	46.0	16.0	202 030	10	202 030 T	10
3.30	49.0	18.0	202 033	10	202 033 T	10
3.50	52.0	20.0	202 035	10	202 035 T	10
4.00	55.0	22.0	202 040	10	202 040 T	10
4.20	55.0	22.0	202 042	10	202 042 T	10
4.50	58.0	24.0	202 045	10	202 045 T	10
5.00	62.0	26.0	202 050	10	202 050 T	10
5.50	66.0	28.0	202 055	10	202 055 T	10
5.00	86.0	52.0	202f 050	10	202 050 F	10
5.50	93.0	57.0	202 055	10	202 055 F	10
6.00	66.0	28.0	202 060	10	202 060 T	10
6.50	70.0	31.0	202 065	10	202 065 T	10
6.80	74.0	34.0	202 068	10	202 068 T	10
7.00	74.0	34.0	202 070	10	202 070 T	10
7.50	74.0	34.0	202 075	10	202 075 T	10
8.00	79.0	37.0	202 080	10	202 080 T	10
8.50	79.0	37.0	202 085	10	202 085 T	10
9.00	84.0	40.0	202 090	10	202 090 T	10
9.50	84.0	40.0	202 095	10	202 095 T	10
10.00	89.0	43.0	202 100	10	202 100 T	10
10.20	89.0	43.0	202 102	10	202 102 T	10
10.50	89.0	43.0	202 105	5	202 105 T	5
11.00	95.0	47.0	202 110	5	202 110 T	5
11.50	95.0	47.0	202 115	5	202 115 T	5
12.00	102.0	51.0	202 120	5	202 120 T	5
12.50	102.0	51.0	202 125	5	202 125 T	5
13.00	102.0	51.0	202 130	5	202 130 T	5



## Doppelendbohrer Typ KV, HSS



Extra kurzer und stabiler Standardbohrer. Noch kürzer als DIN 1897. Hohe Bruchsicherheit. Ideal geeignet für Montagearbeiten in dünnwandigen Materialien wie Blechen, Flach- und Profileisen. Einsatz in Handbohrmaschinen, doppelseitig verwendbar. Hauptsächlich für Nietungen und Karosseriearbeiten. Vorteile DIN 1412 C: gute Zentrierung, geringe Vorschubkraft, durch Spanverteilung verbesserter Spantransport.

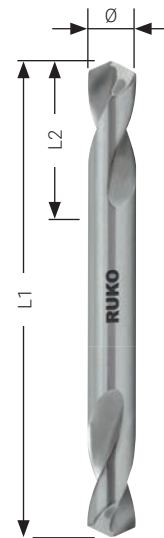

Verpackung: Kunststoff

Ø1 mm	L1 mm	L2 mm	HSS	
2.50	43.0	10.0	252 025	10
2.80	46.0	11.0	252 028	10
3.00	46.0	11.0	252 030	10
3.10	49.0	11.0	252 031	10
3.20	49.0	11.0	252 032	10
3.25	49.0	11.0	252 0325	10
3.30	49.0	11.0	252 033	10
3.40	52.0	14.0	252 034	10
3.50	52.0	14.0	252 035	10
4.00	55.0	14.0	252 040	10
4.10	55.0	14.0	252 041	10

Ø1 mm	L1 mm	L2 mm	HSS	
4.20	55.0	14.0	252 042	10
4.30	58.0	17.0	252 043	10
4.50	58.0	17.0	252 045	10
4.80	62.0	17.0	252 048	10
4.90	62.0	17.0	252 049	10
5.00	62.0	17.0	252 050	10
5.10	62.0	17.0	252 051	10
5.20	62.0	17.0	252 052	10
5.50	66.0	20.0	252 055	10
6.00	66.0	20.0	252 060	10
6.50	70.0	20.0	252 065	10



## Zentrierbohrer DIN 333, HSS



Zentrierbohrer zum Herstellen von Zentrierbohrungen nach Form A.



Verpackung: Kunststoff

Ø1 mm	L1 mm	L2 mm	HSS	
0.80	20.0	3.15	217 008	1
1.00	31.5	3.15	217 010	1
1.60	35.5	4.00	217 016	1
2.00	40.0	5.00	217 020	1
2.50	45.0	6.30	217 025	1
3.15	50.0	8.00	217 315	1
4.00	56.0	10.00	217 040	1
5.00	63.0	12.50	217 050	1
6.30	71.0	16.00	217 063	1

# Verwendung der Bohrer und Schneidbedingungen

Material	Empfohlene Anwendung		Kühlung	Schnittgeschwindigkeit v [m/min]	Bohrerdurchmesser d [mm]				
	Hauptvorschlag	Alternativvorschlag			2	4	6	9	12
					Vorschub f [mm/Umdrehung]				
Automatenstahl 350-500 N/mm <sup>2</sup>	214 ...	258 ... / 202 ...	E	30-40	0,05	0,1	0,125	0,16	0,2
Automatenstahl 500-900 N/mm <sup>2</sup>	214 ...	228 ... / 202 ...	E	25-30	0,04	0,08	0,1	0,125	0,16
Baustahl bis 500 N/mm <sup>2</sup>	214 ...	258 ... / 202 ...	E	30-40	0,04	0,08	0,1	0,125	0,16
Baustahl 500-900 N/mm <sup>2</sup>	214 ...	228 ... / 202 ...	E	20-25	0,032	0,063	0,08	0,1	0,125
Unlegierter Einsatzstahl bis 600 N/mm <sup>2</sup>	214 ...	258 ... / 202 ...	E	25-35	0,05	0,1	0,125	0,16	0,2
Legierter Einsatzstahl 500-900 N/mm <sup>2</sup>	214 ...	228 ... / 202 ...	E	20-25	0,4	0,08	0,1	0,125	0,16
Legierter Einsatzstahl 900-1200 N/mm <sup>2</sup>	281 ... E	202 ... E	E, O	10-15	0,025	0,05	0,063	0,08	0,1
Nitrierstahl 700-900 N/mm <sup>2</sup>	281 ... E	228 ... / 202 ... E	E	15-20	0,032	0,063	0,08	0,1	0,125
Vergüteter Nitrierstahl 800-1250 N/mm <sup>2</sup>	281 ... E	228 ...	E, O	8-12	0,025	0,05	0,063	0,08	0,1
Weichstahl zur Vergütung 500-750 N/mm <sup>2</sup>	214 ...	228 ... / 202 ...	E	25-35	0,04	0,08	0,1	0,125	0,16
Unlegierter Einsatzstahl zur Vergütung 700-1000 N/mm <sup>2</sup>	281 ... E	228 ...	E	15-20	0,04	0,08	0,1	0,125	0,16
Legierter Stahl zur Vergütung 900-1250 N/mm <sup>2</sup>	281 ... E	228 ...	E, O	10-15	0,032	0,063	0,08	0,1	0,125
Manganstahl mit einem Gehalt über 10 % Mn	281 ... E	202 ... E	E, O	3-6	0,2	0,04	0,063	0,08	0,1
Unlegierter Werkzeugstahl 700-900 N/mm <sup>2</sup>	281 ... E	228 ... / 202 ... E	E	14-18	0,032	0,063	0,08	0,1	0,12
Legierter Werkzeugstahl 850-1250 N/mm <sup>2</sup>	281 ... E	228 ...	E, O	8-12	0,025	0,05	0,063	0,08	0,1
Hitzebeständiger Stahl 450-600 N/v	281 ... E	281 ... EF	O	15-20	0,032	0,063	0,08	0,1	0,125
Rostfreie Stähle	215 ...	281 ... E	E, O	6-10	0,02	0,032	0,05	0,08	0,1
Legierungen Hastelloy, Inconel, Nimonic	281 ... E	281 ... EF	O	3-6	0,02	0,04	0,063	0,08	0,125
Grauguß HB 180-240	214 ...	228 ...	E, DL	30-40	0,05	0,1	0,125	0,16	0,2
Grauguß HB 240-300	214 ...	228 ...	E, DL	20-30	0,05	0,1	0,125	0,16	0,2
Temperguß HB 180-240	214 ...	228 ...	DL	20-30	0,05	0,1	0,125	0,16	0,2
Aluminium	258 ... F	258 ...	E	50-80	0,05	0,1	0,125	0,16	0,2
Alu. Legierungen m. e. Gehalt bis 10 % Si u. 180 N/mm <sup>2</sup>	258 ... F	258 ...	E	40-65	0,063	0,1255	0,16	0,2	0,25
Alu. Legierungen / Gehalt bis 10 % Si u. 150-250 N/mm <sup>2</sup>	214 ...	202 ...	E	30-50	0,063	0,1255	0,16	0,2	0,25
Kupfer 200-400 N/mm <sup>2</sup>	258 ... F	228 ...	E, O	30-40	0,05	0,1	0,125	0,16	0,2
Sprödes Messing mit kurzem Span 350-550 N/mm <sup>2</sup>	281 ... E	281 ... EF	E, O	60-80	0,063	0,1255	0,16	0,2	0,25
Zähes Messing mit langem Span 250-550 N/mm <sup>2</sup>	258 ... F	258 ... F	E, O	30-50	0,063	0,1	0,125	0,16	0,2
Bronze 200-500 N/mm <sup>2</sup>	258 ... F	258 ... F	E, O	20-40	0,05	0,08	0,125	0,16	0,2
Bronze 500-800 N/mm <sup>2</sup>	214 ...	258 ...	E, O	15-30	0,05	0,08	0,125	0,16	0,2
Magnesiumlegierungen-Elektron	281 ... E	281 ... EF	-	60-100	0,08	0,125	0,016	0,02	0,25
Zink, Zinklegierungen	214 ...	258 ...	E	35-45	0,05	0,1	0,125	0,16	0,2
Titanlegierungen bis 700 N/mm <sup>2</sup>	281 ... E	281 ... EF	O	3-6	0,03	0,05	0,063	0,08	0,1
Titanlegierungen 700-1000 N/mm <sup>2</sup>	281 ... E	281 ... EF	O	3-6	0,02	0,04	0,05	0,063	0,08
Silber	214 ...	258 ...	E	30-40	0,05	0,08	0,1	0,125	0,16
Duromoren	281 ... E	281 ... EF	DL	10-20	0,04	0,08	0,1	0,125	0,16
Thermoplasten	258 ... F	258 ... F	W, DL	20-40	0,05	0,1	0,125	0,16	0,2
Geschichtete Material (Papier, Holz) längs der Schicht	258 ... F	258 ... F	DL	15-25	0,05	0,08	0,125	0,16	0,2

E = Emulsion / O = Schneidöl / DL = Druckluft / W = Wasser

# Drehzahltablelle für Spiralbohrer

01

Werkstoff	Schnittgeschw. Vc m/min	Kühl-schmierstoff	Werkstoff	Schnittgeschw. Vc m/min	Kühl-schmierstoff
unlegierte Baustähle < 700 N/mm <sup>2</sup>	30 - 35	Schneidspray	CuZn-Legierungen zäh Al-Legierungen bis 11 % Si Thermoplaste Duroplaste mit anorgan. Füllung Duroplaste mit organ. Füllung	35 - 60 30 - 50 20 - 40 15 - 25 15 - 35	Druckluft Schneidspray Wasser Druckluft Druckluft
legierte Baustähle > 700 N/mm <sup>2</sup>	20 - 25	Schneidspray			
legierte Stähle < 1000 N/mm <sup>2</sup>	20 - 25	Schneidspray			
Gußeisen < 250 N/mm <sup>2</sup>	15 - 25	Druckluft			
Gußeisen > 250 N/mm <sup>2</sup>	10 - 20	Druckluft			
CuZn-Legierungen spröde	60 - 100	Druckluft			

Bohrer Ø mm	Schnittgeschwindigkeit Vc = m/min															
	4	6	8	10	12	15	18	20	25	30	35	40	50	60	80	100
	Drehzahl U/min															
1.0	1274	1911	2548	3185	3822	4777	5732	6369	7962	9554	11146	12739	15924	19108	25478	31847
1.5	849	1274	1699	2123	2548	3185	3822	4246	5308	6369	7431	8493	10616	12739	16985	21231
2.0	637	955	1274	1592	1911	2389	2866	3185	3981	4777	5573	6369	7962	9554	12739	15924
2.5	510	764	1019	1274	1529	1911	2293	2548	3185	3822	4459	5096	6369	7643	10191	12739
3.0	425	637	849	1062	1274	1592	1911	2123	2654	3185	3715	4246	5308	6369	8493	10616
3.5	364	546	728	910	1092	1365	1638	1820	2275	2730	3185	3640	4550	5460	7279	9099
4.0	318	478	637	796	955	1194	1433	1592	1990	2389	2787	3185	3981	4777	6369	7962
4.5	283	425	566	708	849	1062	1274	1415	1769	2123	2477	2831	3539	4246	5662	7077
5.0	255	382	510	637	764	955	1146	1274	1592	1911	2229	2548	3185	3822	5096	6369
5.5	232	347	463	579	695	869	1042	1158	1448	1737	2027	2316	2895	3474	4632	5790
6.0	212	318	425	531	637	796	955	1062	1327	1592	1858	2123	2654	3185	4246	5308
6.5	196	294	392	490	588	735	882	980	1225	1470	1715	1960	2450	2940	3920	4900
7.0	182	273	364	455	546	682	819	910	1137	1365	1592	1820	2275	2730	3640	4550
7.5	170	255	340	425	510	637	764	849	1062	1274	1486	1699	2123	2548	3397	4246
8.0	159	239	318	398	478	597	717	796	995	1194	1393	1592	1990	2389	3185	3981
8.5	150	225	300	375	450	562	674	749	937	1124	1311	1499	1873	2248	2997	3747
9.0	142	212	283	354	425	531	637	708	885	1062	1238	1415	1769	2123	2831	3539
9.5	134	201	268	335	402	503	603	670	838	1006	1173	1341	1676	2011	2682	3352
10.0	127	191	255	318	382	478	573	637	796	955	1115	1274	1592	1911	2548	3185
11.0	116	174	232	290	347	434	521	579	724	869	1013	1158	1448	1737	2316	2895
12.0	106	159	212	265	318	398	478	531	663	796	929	1062	1327	1592	2123	2654
13.0	98	147	196	245	294	367	441	490	612	735	857	980	1225	1470	1960	2450
14.0	91	136	182	227	273	341	409	455	569	682	796	910	1137	1365	1820	2275
15.0	85	127	170	212	255	318	382	425	531	637	743	849	1062	1274	1699	2123
16.0	80	119	159	199	239	299	358	398	498	597	697	796	995	1194	1592	1990
17.0	75	112	150	187	225	281	337	375	468	562	656	749	937	1124	1499	1873
18.0	71	106	142	177	212	265	318	354	442	531	619	708	885	1062	1415	1769
19.0	67	101	134	168	201	251	302	335	419	503	587	670	838	1006	1341	1676
20.0	64	96	127	159	191	239	287	318	398	478	557	637	796	955	1274	1592
21.0	61	91	121	152	182	227	273	303	379	455	531	607	758	910	1213	1517
22.0	58	87	116	145	174	217	261	290	362	434	507	579	724	869	1158	1448
23.0	55	83	111	138	166	208	249	277	346	415	485	554	692	831	1108	1385
24.0	53	80	106	133	159	199	239	265	332	398	464	531	663	796	1062	1327
25.0	51	76	102	127	153	191	229	255	318	382	446	510	637	764	1019	1274
26.0	49	73	98	122	147	184	220	245	306	367	429	490	612	735	980	1225
27.0	47	71	94	118	142	177	212	236	295	354	413	472	590	708	944	1180
28.0	45	68	91	114	136	171	205	227	284	341	398	455	569	682	910	1137
29.0	44	66	88	110	132	165	198	220	275	329	384	439	549	659	879	1098
30.0	42	64	85	106	127	159	191	212	265	318	372	425	531	637	849	1062
31.0	41	62	82	103	123	154	185	205	257	308	360	411	514	616	822	1027
32.0	40	60	80	100	119	149	179	199	249	299	348	398	498	597	796	995
33.0	39	58	77	97	116	145	174	193	241	290	338	386	483	579	772	965
34.0	37	56	75	94	112	141	169	187	234	281	328	375	468	562	749	937
35.0	36	55	73	91	109	136	164	182	227	273	318	364	455	546	728	910
36.0	35	53	71	88	106	133	159	177	221	265	310	354	442	531	708	885
37.0	34	52	69	86	103	129	155	172	215	258	301	344	430	516	689	861
38.0	34	50	67	84	101	126	151	168	210	251	293	335	419	503	670	838
39.0	33	49	65	82	98	122	147	163	204	245	286	327	408	490	653	817
40.0	32	48	64	80	96	119	143	159	199	239	279	318	398	478	637	796
41.0	31	47	62	78	93	117	140	155	194	233	272	311	388	466	621	777
42.0	30	45	61	76	91	114	136	152	190	227	265	303	379	455	607	758
43.0	30	44	59	74	89	111	133	148	185	222	259	296	370	444	593	741
44.0	29	43	58	72	87	109	130	145	181	217	253	290	362	434	579	724
45.0	28	42	57	71	85	106	127	142	177	212	248	283	354	425	566	708
46.0	28	42	55	69	83	104	125	138	173	208	242	277	346	415	554	692
47.0	27	41	54	68	81	102	122	136	169	203	237	271	339	407	542	678
48.0	27	40	53	66	80	100	119	133	166	199	232	265	332	398	531	663
49.0	26	39	52	65	78	97	117	130	162	195	227	260	325	390	520	650
50.0	25	38	51	64	76	96	115	127	159	191	223	255	318	382	510	637

# Drehzahltable für Spiralbohrer



Werkstoff	Schnittgeschw. Vc m/min	Kühl- schmierstoff	Werkstoff	Schnittgeschw. Vc m/min	Kühl- schmierstoff
unlegierte Baustähle < 700 N/mm <sup>2</sup>	30 - 35	Schneidspray	CuZn-Legierungen zäh	35 - 60	Druckluft
legierte Baustähle > 700 N/mm <sup>2</sup>	20 - 25	Schneidspray	Al-Legierungen bis 11 % Si	30 - 50	Schneidspray
legierte Stähle < 1000 N/mm <sup>2</sup>	20 - 25	Schneidspray	Thermoplaste	20 - 40	Wasser
Gußeisen < 250 N/mm <sup>2</sup>	15 - 25	Druckluft	Duroplaste mit anorgan. Füllung	15 - 25	Druckluft
Gußeisen > 250 N/mm <sup>2</sup>	10 - 20	Druckluft	Duroplaste mit organ. Füllung	15 - 35	Druckluft
CuZn-Legierungen spröde	60 - 100	Druckluft			

Bohrer Ø Zoll	Schnittgeschwindigkeit Vc = m/min															
	4	6	8	10	12	15	18	20	25	30	35	40	50	60	80	100
	Drehzahl U/min															
1/16	800	1190	1590	1990	2390	2990	3580	3980	4980	5970	6970	7960	9950	11940	15920	19900
5/64	640	960	1270	1590	1910	2390	2870	3180	3980	4780	5570	6370	7960	9550	12740	15920
3/32	530	800	1060	1330	1590	1990	2390	2650	3320	3980	4640	5310	6630	7960	10620	13270
7/64	450	680	910	1140	1360	1710	2050	2270	2840	3410	3980	4550	5690	6820	9100	11370
1/8	400	600	800	1000	1190	1490	1790	1990	2490	2990	3480	3980	4980	5970	7960	9950
9/64	350	530	710	880	1060	1330	1590	1770	2210	2650	3100	3540	4420	5310	7080	8850
5/32	320	480	640	800	960	1190	1430	1590	1990	2390	2790	3180	3980	4780	6370	7960
11/64	290	430	580	720	870	1090	1300	1450	1810	2170	2530	2900	3620	4340	5790	7240
3/16	270	400	530	660	800	1000	1190	1330	1660	1990	2320	2650	3320	3980	5310	6630
13/64	240	370	490	610	730	920	1100	1220	1530	1840	2140	2450	3060	3670	4900	6120
7/32	230	340	450	570	680	850	1020	1140	1420	1710	1990	2270	2840	3410	4550	5690
15/64	210	320	420	530	640	800	960	1060	1330	1590	1860	2120	2650	3180	4250	5310
1/4	200	300	400	500	600	750	900	1000	1240	1490	1740	1990	2490	2990	3980	4980
17/64	190	290	380	480	570	710	860	950	1190	1430	1660	1900	2380	2850	3800	4750
9/32	180	270	360	450	540	670	810	900	1120	1350	1570	1790	2240	2690	3590	4490
19/64	170	250	340	420	510	640	760	850	1060	1270	1490	1700	2120	2550	3400	4250
5/16	160	240	320	400	480	600	730	810	1010	1210	1410	1610	2020	2420	3230	4030
21/64	150	230	310	380	460	580	690	770	960	1150	1340	1530	1920	2300	3070	3840
11/32	150	220	290	370	440	550	660	730	920	1100	1280	1460	1830	2200	2930	3660
23/64	140	210	280	350	420	520	630	700	870	1050	1220	1400	1750	2100	2800	3500
3/8	130	200	270	340	400	500	600	670	840	1010	1170	1340	1680	2010	2680	3350
25/64	130	190	260	320	390	480	580	640	800	970	1130	1290	1610	1930	2570	3220
13/32	120	190	250	310	370	460	560	620	770	930	1080	1240	1550	1860	2470	3090
27/64	120	180	240	300	360	450	540	600	740	890	1040	1190	1490	1790	2380	2980
7/16	110	170	230	290	340	430	520	570	720	860	1000	1150	1430	1720	2300	2870
29/64	110	170	220	280	330	420	500	550	690	830	970	1110	1380	1660	2220	2770
15/32	110	160	210	270	320	400	480	540	670	800	940	1070	1340	1610	2140	2680
31/64	110	160	210	260	310	390	470	520	650	780	910	1040	1290	1550	2070	2590
1/2	110	150	200	250	300	380	450	500	630	750	880	1000	1250	1500	2010	2510

02



# SPEZIALBOHRER

Schweißpunktfräser HSS	62
Schweißpunktbohrer HSSE-Co 5 + HSSE-Co 5 TiCN + Hartmetall AlTiN	63
Fräsbohrer HSS + TiN	63
Drehzahltable für Spezialbohrer	64

## Schweißpunktfräser HSS

02



Zum Lösen von punktgeschweißten Blechteilen. Die Fräser sind oxidiert, beidseitig schneidend und auswechselbar. Die Frästiefe ist durch eine Schraube einstellbar. Keine Deformierung des Bleches. Rationelles und schnelles Arbeiten.

		L1 mm	Ø mm	HSS
<b>1</b> Stk./pcs.	Schweißpunktfräser, komplett	72.0	-	101 101
<b>5</b> Stk./pcs.	Fräskrone	-	9.6	101 102
<b>1</b> Stk./pcs.	Zentrierstift	-	2.5	101 103

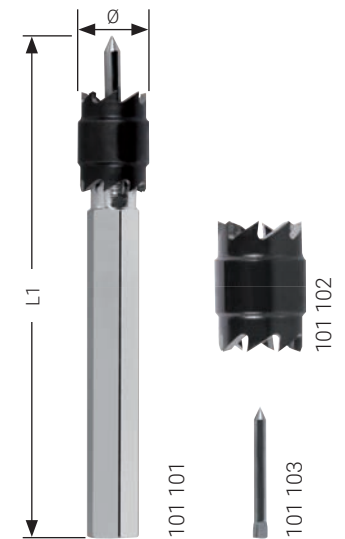

Verpackung: Kunststoff

		HSS
<b>13</b> Stk./pcs.	Schweißpunktfräser-Satz 1 Schweißpunktfräser, komplett + 10 Fräskronen + 2 Zentrierstifte	101 104

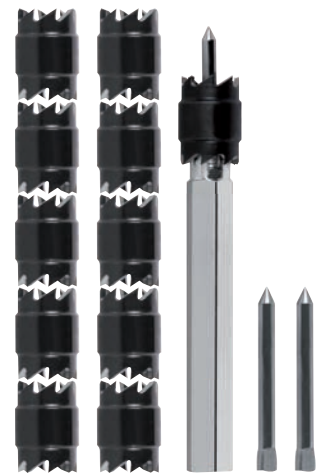

Verpackung: Kunststoff

		HSS HSSE-Co 5
<b>9</b> Stk./pcs.	Schweißpunktfräser-Sondersatz 1 Schweißpunktfräser, komplett + 5 Fräskronen + 2 Zentrierstifte + 1 Fast Cut HSSE-Co 5 - Ø 8.0 mm	101 104 M







## Schweißpunktbohrer HSSE-Co 5 und Hartmetall



Extra stabile Konstruktion für schwierige Bohrbedingungen mit der Handbohrmaschine. Besonders geeignet zum Ausbohren von Schweißpunkten und zum Bohren dünnwandiger Werkstücke. Extrem hohe Präzision und gratfreies Bohren ohne Ankrönen. Zum Bohren von Stahlblech, Messingblech, Aluminiumblech, Zinkblech, Kupferblech, Kunststoffplatten.

Verpackung: Kunststoff

Ø mm	L1 mm	HSSE-Co 5	HSSE-Co 5 TiCN	HM / TC AITiN
6.0	66.0	101 107	101 107 TC	101 107 HM
7.0	74.0	101 111	—	—
8.0	80.0	101 108	101 108 TC	101 108 HM
10.0	88.0	101 114	101 114 TC	—



## Fräsbohrer HSS

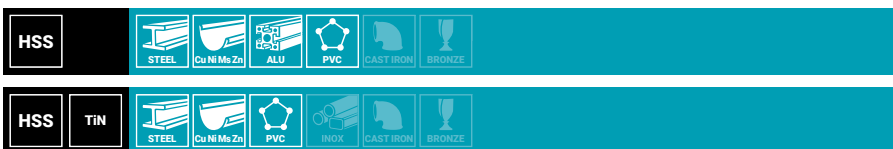

Zum Bohren und Fräsen in Blech, Holz, Kunststoff und dünnwandige Materialien. Kurzer Spiralbohrerteil, übergehend in Frässchneiden mit Spanbrechern.

Verpackung: Kunststoff

Ø mm	L1 mm	HSS	HSS TiN
6.0	90.0	101 201	101 201 T
8.0	90.0	101 202	101 202 T

# Drehzahltablette für Spezialbohrer



Werkstoff	Schnittgeschw. Vc m/min	Kühl- schmierstoff	Werkstoff	Schnittgeschw. Vc m/min	Kühl- schmierstoff
unlegierte Baustähle < 700 N/mm <sup>2</sup>	30 - 35	Schneidspray	CuZn-Legierungen zäh Al-Legierungen bis 11 % Si Thermoplaste Duroplaste mit anorgan. Füllung Duroplaste mit organ. Füllung	35 - 60 30 - 50 20 - 40 15 - 25 15 - 35	Druckluft Schneidspray Wasser Druckluft Druckluft
legierte Baustähle > 700 N/mm <sup>2</sup>	20 - 25	Schneidspray			
legierte Stähle < 1000 N/mm <sup>2</sup>	20 - 25	Schneidspray			
Gußeisen < 250 N/mm <sup>2</sup>	15 - 25	Druckluft			
Gußeisen > 250 N/mm <sup>2</sup>	10 - 20	Druckluft			
CuZn-Legierungen spröde	60 - 100	Druckluft			

Bohrer Ø mm	Schnittgeschwindigkeit Vc = m/min															
	4	6	8	10	12	15	18	20	25	30	35	40	50	60	80	100
	Drehzahl U/min															
1.0	1274	1911	2548	3185	3822	4777	5732	6369	7962	9554	11146	12739	15924	19108	25478	31847
1.5	849	1274	1699	2123	2548	3185	3822	4246	5308	6369	7431	8493	10616	12739	16985	21231
2.0	637	955	1274	1592	1911	2389	2866	3185	3981	4777	5573	6369	7962	9554	12739	15924
2.5	510	764	1019	1274	1529	1911	2293	2548	3185	3822	4459	5096	6369	7643	10191	12739
3.0	425	637	849	1062	1274	1592	1911	2123	2654	3185	3715	4246	5308	6369	8493	10616
3.5	364	546	728	910	1092	1365	1638	1820	2275	2730	3185	3640	4550	5460	7279	9099
4.0	318	478	637	796	955	1194	1433	1592	1990	2389	2787	3185	3981	4777	6369	7962
4.5	283	425	566	708	849	1062	1274	1415	1769	2123	2477	2831	3539	4246	5662	7077
5.0	255	382	510	637	764	955	1146	1274	1592	1911	2229	2548	3185	3822	5096	6369
5.5	232	347	463	579	695	869	1042	1158	1448	1737	2027	2316	2895	3474	4632	5790
6.0	212	318	425	531	637	796	955	1062	1327	1592	1858	2123	2654	3185	4246	5308
6.5	196	294	392	490	588	735	882	980	1225	1470	1715	1960	2450	2940	3920	4900
7.0	182	273	364	455	546	682	819	910	1137	1365	1592	1820	2275	2730	3640	4550
7.5	170	255	340	425	510	637	764	849	1062	1274	1486	1699	2123	2548	3397	4246
8.0	159	239	318	398	478	597	717	796	995	1194	1393	1592	1990	2389	3185	3981
8.5	150	225	300	375	450	562	674	749	937	1124	1311	1499	1873	2248	2997	3747
9.0	142	212	283	354	425	531	637	708	885	1062	1238	1415	1769	2123	2831	3539
9.5	134	201	268	335	402	503	603	670	838	1006	1173	1341	1676	2011	2682	3352
10.0	127	191	255	318	382	478	573	637	796	955	1115	1274	1592	1911	2548	3185
11.0	116	174	232	290	347	434	521	579	724	869	1013	1158	1448	1737	2316	2895
12.0	106	159	212	265	318	398	478	531	663	796	929	1062	1327	1592	2123	2654
13.0	98	147	196	245	294	367	441	490	612	735	857	980	1225	1470	1960	2450
14.0	91	136	182	227	273	341	409	455	569	682	796	910	1137	1365	1820	2275
15.0	85	127	170	212	255	318	382	425	531	637	743	849	1062	1274	1699	2123
16.0	80	119	159	199	239	299	358	398	498	597	697	796	995	1194	1592	1990
17.0	75	112	150	187	225	281	337	375	468	562	656	749	937	1124	1499	1873
18.0	71	106	142	177	212	265	318	354	442	531	619	708	885	1062	1415	1769
19.0	67	101	134	168	201	251	302	335	419	503	587	670	838	1006	1341	1676
20.0	64	96	127	159	191	239	287	318	398	478	557	637	796	955	1274	1592
21.0	61	91	121	152	182	227	273	303	379	455	531	607	758	910	1213	1517
22.0	58	87	116	145	174	217	261	290	362	434	507	579	724	869	1158	1448
23.0	55	83	111	138	166	208	249	277	346	415	485	554	692	831	1108	1385
24.0	53	80	106	133	159	199	239	265	332	398	464	531	663	796	1062	1327
25.0	51	76	102	127	153	191	229	255	318	382	446	510	637	764	1019	1274
26.0	49	73	98	122	147	184	220	245	306	367	429	490	612	735	980	1225
27.0	47	71	94	118	142	177	212	236	295	354	413	472	590	708	944	1180
28.0	45	68	91	114	136	171	205	227	284	341	398	455	569	682	910	1137
29.0	44	66	88	110	132	165	198	220	275	329	384	439	549	659	879	1098
30.0	42	64	85	106	127	159	191	212	265	318	372	425	531	637	849	1062
31.0	41	62	82	103	123	154	185	205	257	308	360	411	514	616	822	1027
32.0	40	60	80	100	119	149	179	199	249	299	348	398	498	597	796	995
33.0	39	58	77	97	116	145	174	193	241	290	338	386	483	579	772	965
34.0	37	56	75	94	112	141	169	187	234	281	328	375	468	562	749	937
35.0	36	55	73	91	109	136	164	182	227	273	318	364	455	546	728	910
36.0	35	53	71	88	106	133	159	177	221	265	310	354	442	531	708	885
37.0	34	52	69	86	103	129	155	172	215	258	301	344	430	516	689	861
38.0	34	50	67	84	101	126	151	168	210	251	293	335	419	503	670	838
39.0	33	49	65	82	98	122	147	163	204	245	286	327	408	490	653	817
40.0	32	48	64	80	96	119	143	159	199	239	279	318	398	478	637	796
41.0	31	47	62	78	93	117	140	155	194	233	272	311	388	466	621	777
42.0	30	45	61	76	91	114	136	152	190	227	265	303	379	455	607	758
43.0	30	44	59	74	89	111	133	148	185	222	259	296	370	444	593	741
44.0	29	43	58	72	87	109	130	145	181	217	253	290	362	434	579	724
45.0	28	42	57	71	85	106	127	142	177	212	248	283	354	425	566	708
46.0	28	42	55	69	83	104	125	138	173	208	242	277	346	415	554	692
47.0	27	41	54	68	81	102	122	136	169	203	237	271	339	407	542	678
48.0	27	40	53	66	80	100	119	133	166	199	232	265	332	398	531	663
49.0	26	39	52	65	78	97	117	130	162	195	227	260	325	390	520	650
50.0	25	38	51	64	76	96	115	127	159	191	223	255	318	382	510	637

GSR-02

The screen displays a data table with the following structure:

Station	Time	Time	Time	Time	Time
Station 1	00:00	00:00	00:00	00:00	00:00
Station 2	00:00	00:00	00:00	00:00	00:00
Station 3	00:00	00:00	00:00	00:00	00:00
Station 4	00:00	00:00	00:00	00:00	00:00
Station 5	00:00	00:00	00:00	00:00	00:00
Station 6	00:00	00:00	00:00	00:00	00:00
Station 7	00:00	00:00	00:00	00:00	00:00
Station 8	00:00	00:00	00:00	00:00	00:00
Station 9	00:00	00:00	00:00	00:00	00:00
Station 10	00:00	00:00	00:00	00:00	00:00

BECKHOFF



03



# BLECHSCHÄLBOHRER

HSS + TiN + HSSE-Co 5 mit Kreuzanschliff	68
Bit HSS mit Kreuzanschliff	69
Drehzahltablette für Blechschälbohrer	70

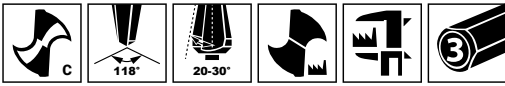

## Blechsälbohrer HSS und HSSE-Co 5 mit Kreuzanschliff

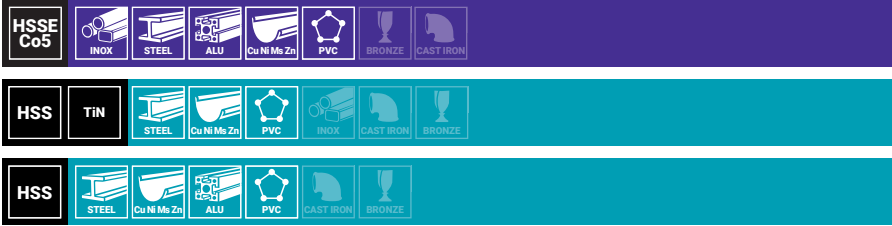

Die tiefgeschliffene Spanant bietet absolute Laufruhe und hohe Schnittleistung. Der Konus erleichtert das Zurückziehen bei durchgebohrten Blechen.

Verpackung: Kunststoff

Größe Nr.	Ø1 - Ø2 mm	L1 mm	Ø3 mm	HSS		HSS TiN		HSSE-Co 5	
1	3.0 - 14.0	58.0	6.0	101 001	1	101 001 T	1	101 001 E	1
2	4.0 - 20.0	71.0	8.0	101 002	1	101 002 T	1	101 002 E	1
3	16.0 - 30.5	76.0	9.0	101 003	1	101 003 T	1	101 003 E	1
4	24.0 - 40.0	89.0	10.0	101 004	1	101 004 T	—	—	—
5	36.0 - 50.0	97.0	12.0	101 005	1	—	—	—	—
6	40.0 - 61.0	103.0	13.0	101 006	1	—	—	—	—
7	5.0 - 25.4	87.0	10.0	101 007	1	—	—	—	—
8	5.0 - 31.0	103.0	9.0	101 008	1	101 008 T	1	101 008 E	1
9	5.0 - 22.5	79.0	8.0	101 022	1	—	—	—	—

		HSS	HSS TiN	HSSE-Co 5
<b>4</b> tlg./pcs.	Blechsälbohrer-Satz in den Größen 1, 2, 3 und 1 Dose Schneidpaste 20 g	101 020 RO	101 020 TRO	101 020 ERO





## Bleeschälbohrer-Bit HSS mit Kreuzanschliff



Die tiefgeschliffene Spannute bietet absolute Laufruhe und hohe Schnittleistung. Der Konus erleichtert das Zurückziehen bei durchgebohrten Blechen.

Verpackung: Kunststoff

Größe Nr.	Ø1 - Ø2 mm	L1 mm	Ø3 mm	Ø3 Zoll	HSS	
2	5.0 - 20.0	78.0	6.35 x 27.0	1/4"	101 049 H	1



## Produktbeschreibung

### 1. CBN-tiefgeschliffene Spannkammer

Durch die CBN-tiefgeschliffenen Spannuten sind die Schneiden im Gegensatz zu den herkömmlich bekannten gefrästen Spannuten gratfrei und scharf. Daraus resultiert eine wesentlich höhere Schneidleistung und eine wesentlich bessere Standzeit.

### 2. Radial angepasster CBN-Hinterschliff

Durch den radialen CBN-Hinterschliff ist die Schneide der eindeutig höchste Punkt im Durchmesser.

### 3. Spannute

Die gerade oder spiralförmige Spannute bietet absolute Laufruhe und hohe Schnittleistung. Bei der spiralförmigen Spannute werden insbesondere nicht brechende Späne wie bei einem Spiralbohrer sauber abtransportiert.

### 4. Konus am Ende des Bleeschälbohrers

Der Konus am Ende des Bleeschälbohrers erleichtert das Zurückziehen bei durchgebohrten Blechen.

### 5. Bohrspitze mit Kreuzanschliff DIN 1412 C

Die Hochleistungsbohrspitze mit CBN-Sonderanschliff ermöglicht das Zentrieren und Anbohren auch von dünnwandigen Materialien.

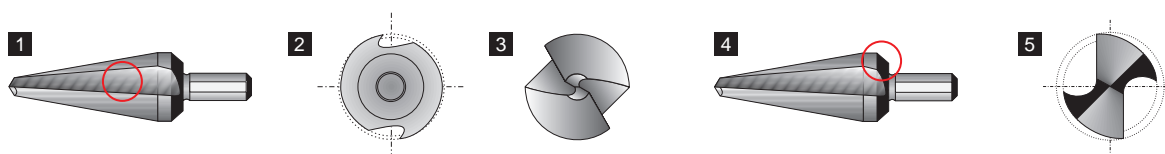

# Drehzahltable für Bleeschälbohrer

Material:		unleg. Baustahl  bis 700 N/mm <sup>2</sup>	unleg. Baustahl  über 700 N/mm <sup>2</sup>	legierte Stähle  bis 1000 N/mm <sup>2</sup>	Gusseisen  bis 250 N/mm <sup>2</sup>	Gusseisen  über 250 N/mm <sup>2</sup>	CuZn- Legierung  spröde	CuZn- Legierung  zäh	Al- Legierung  bis 11% Si	Thermo- plaste	Duro- plaste
Blechstärke in mm:		bis 4,0	bis 4,0	bis 4,0	bis 4,0	bis 4,0	bis 4,0	bis 4,0	bis 4,0	bis 4,0	bis 4,0
Vc = m/min		30	20	20	15	10	60	35	30	20	15
Kühlschmierstoff:		Schneid- spray	Schneid- spray	Schneid- spray	Druck- luft	Druck- luft	Druck- luft	Druck- luft	Schneid- spray	Wasser	Druck- luft
Größe	Ø mm	U/min	U/min	U/min	U/min	U/min	U/min	U/min	U/min	U/min	U/min
Nr. 1	3,0-14,0	3185-682	2123-455	2123-455	1592-341	1062-227	6369-1365	3715-796	3185-682	2123-455	1592-341
Nr. 2	4,0-20,0	1911-478	1274-318	1274-318	955-239	637-159	3822- 955	2229-557	1911-478	1274-318	955-239
Nr. 3	16,0-30,5	597-313	398-209	398-209	299-157	199-104	1194- 627	697-365	597-313	398-209	299-157
Nr. 4	24,0-40,0	398-239	265-159	265-159	199-119	133- 80	796- 478	464-279	398-239	265-159	199-119
Nr. 5	36,0-50,0	265-191	177-127	177-127	133- 96	88- 64	531- 382	310-223	265-191	177-127	133- 96
Nr. 6	40,0-61,0	239-157	159-104	159-104	119- 78	80- 52	478- 313	279-183	239-157	159-104	119- 78
Nr. 7	5,0-25,4	1911-376	1274-251	1274-251	955-188	637-125	3822- 752	2229-439	1911-376	1274-251	955-188
Nr. 8	5,0-31,0	1911-308	1274-205	1274-205	955-154	637-103	3822- 616	2229-360	1911-308	1274-205	955-154
Nr. 9	5,0-22,5	1911-425	1274-283	1274-283	955-212	637-142	3822- 849	2229-495	1911-425	1274-283	955-212







04

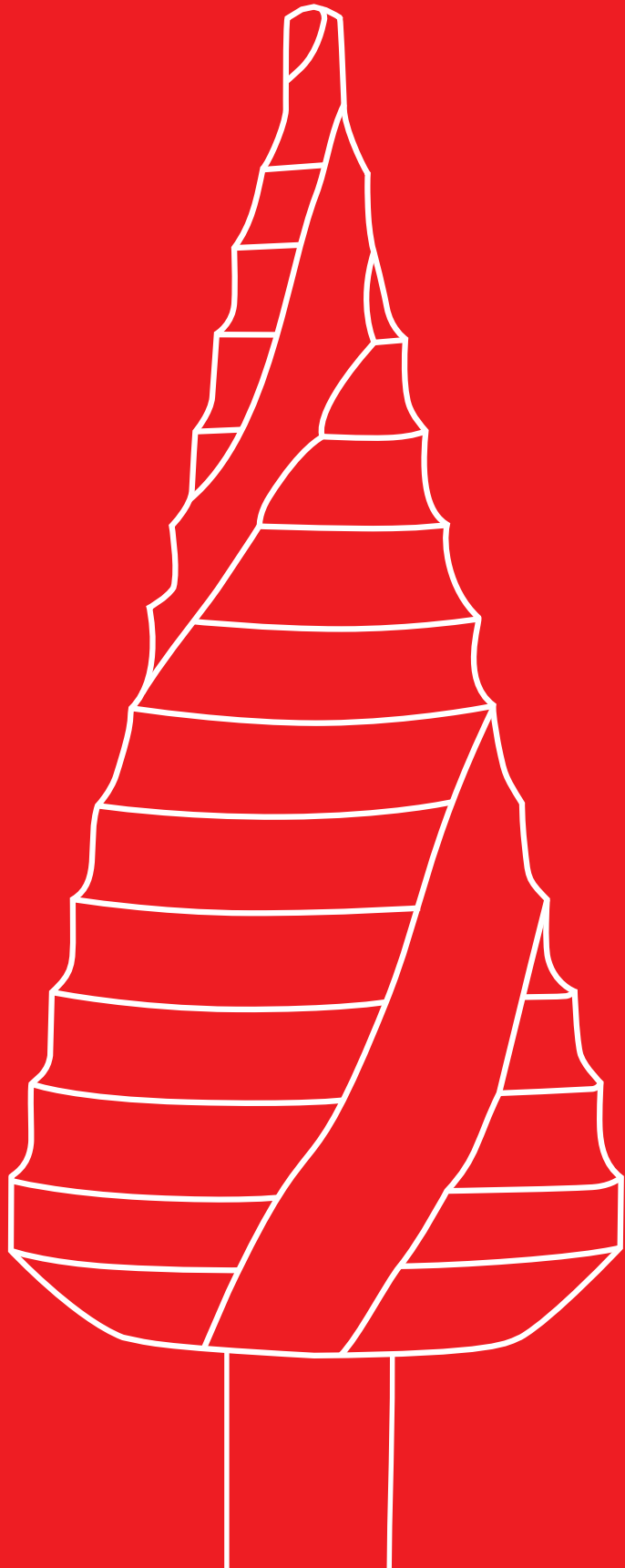

# STUFENBOHRER

Typen- und Anwendungsübersicht	76 – 79
ULTIMATECUT HSSE-Co 5 + RUnATEC, spiralgenutet mit FLOWSTEP® Spitze	80
ULTIMATECUT HSS + RUnATEC, spiralgenutet mit FLOWSTEP® Spitze	81
HSS + TiN + TiAlN + HSSE-Co 5, spiralgenutet	82 – 83
Leitplankenstufenbohrer HSS TiAlN, spiralgenutet	83
Bit HSS + TiN, spiralgenutet	84
HSS, spiralgenutet – kurz	84
HSS + TiN + TiAlN + HSSE-Co 5, spiralgenutet – Zollabmessungen	85
HSS + TiN, mit 3 Schneiden, gerade Nut	86
HSS + TiN + TiAlN spiralgenutet, für metrische Kabelverschraubungen	87
Aufbohrer HSS ohne Spitze	87
Mehrfasenstufenbohrer Typ N, HSS	88
Kurzstufenbohrer Typ N, HSS	89
Drehzahltablette für Stufenbohrer	90
Anwendungstabelle für Stufenbohrer	91
ULTIMATECUT Multidrill HSS RUnATEC	94

**ULTIMATECUT<sup>®</sup>**

# Stufenbohrer mit FLOWSTEP<sup>®</sup> Spitze

Er lässt dich 6-mal mehr bohren.  
Er lässt dich 75 % schneller anbohren.  
Er lässt dich perfekt zentrieren.



## **RUKO** FLOWSTEP<sup>®</sup> Spitze

Punktgenaues Zentrieren = kein Verrutschen beim Bohren.  
Zeitersparnis durch schnelleres Anbohren = mehr Löcher in derselben Zeit bohren.  
Kräftesparendes Bohren = mehr Löcher ohne Pause bohren.

**RUna  
TEC**

### **RUKO RUnaTEC-Beschichtung**

Durch die RUKO nano Technology (RUnaTEC) können neben niedrigen vor allem sehr hohe Schnittgeschwindigkeiten gefahren und somit Arbeitsvorgänge deutlich beschleunigt werden.

Weitere positive Eigenschaften sind die extrem hohe Verschleißfestigkeit und die starke Reduzierung der Materialverschweißungen.

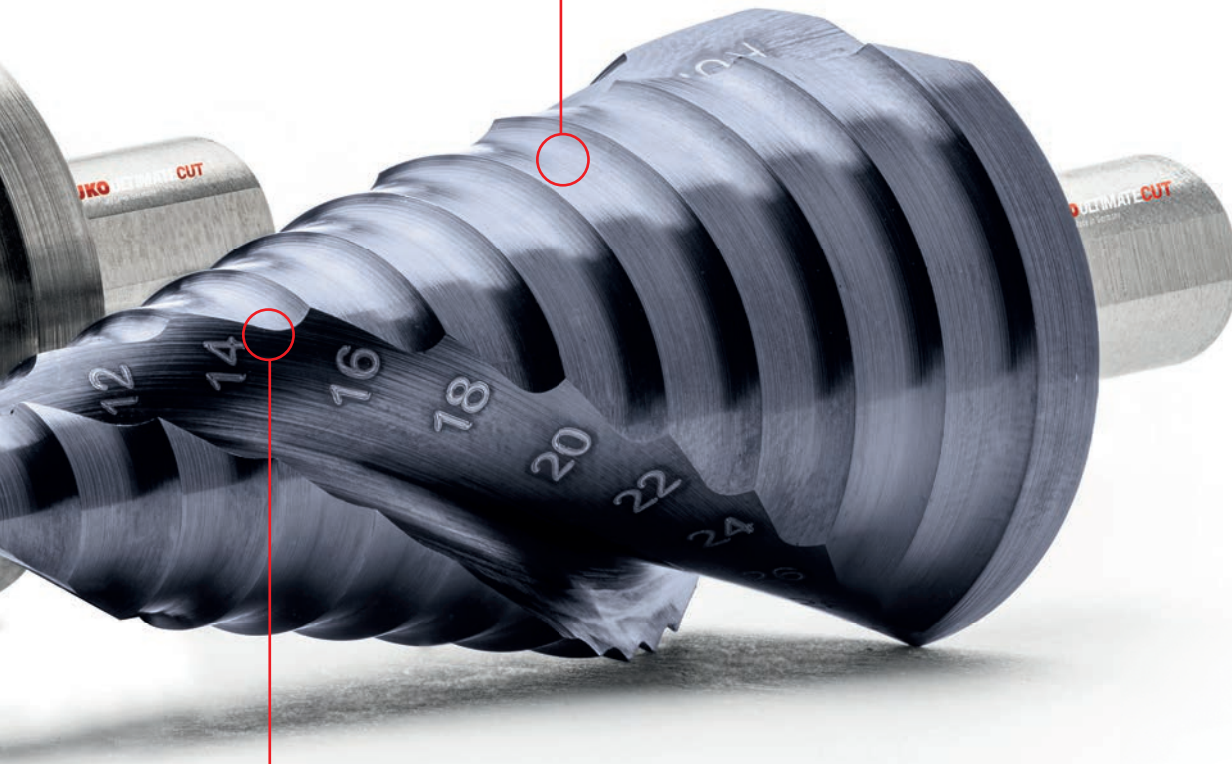







































































































### **RUKO FLOWSTEP® Technologie**

Kontrollierbar bei empfindlichen Werkstoffen, wie dünnwandigen Blechen und Acrylglas.  
Kraftvoll bei zähen Werkstoffen, wie Edelstahl.

Die Schneidengeometrie ermöglicht einen weichen, nahtlosen Übergang zwischen den verschiedenen Durchmessern.

# Typen- und Anwendungsübersicht

04



























	Werkstoff	Oberfläche	Schneiden	Materialstärke	Spitzenwinkel	Spitzenanschliff	Schaft	Ø mm	Art.-Nr.	Seite/n
	<b>NEW</b> <b>ULTIMATECUT®</b> HSSE Co5	RUna TEC		 4 mm				5 - 38	101 6xx EP	80
	HSSE Co5	Blank		 4 mm					101 6xx E	
	HSS	RUna TEC		 4 mm					101 6xx	81
	HSS	Blank		 4 mm					101 6xx P	
	<b>ULTIMATECUT®</b> HSS	RUna TEC		 10 mm				6,0 - 27,0	101 0xx P	94
	HSS	Blank		 4 mm	 118°			4,0 - 40,0	101 xxx	82 - 83
	HSSE Co5	Blank		 4 mm	 118°			4,0 - 32,5	101 xxx E	
	HSS	TiN		 4 mm	 118°			4,0 - 40,0	101 xxx T	
	HSS	TiAlN		 4 mm	 118°			4,0 - 40,0	101 xxx F	
	HSS	TiAlN		 3.5 mm	 118°			6,0 - 18,0	101 068 F-1	83
	HSS	Blank		 4 mm	 118°			4,0 - 12,0	101 xxx H	84
	HSS	TiN		 4 mm	 118°			4,0 - 30,0	101 xxx H	
	HSS	Blank		 2 mm	 118°			4,0 - 30,0	101 06x	84
	HSS	TiN		 2 mm	 118°			4,0 - 30,0	101 06x T	
	HSS	Blank		 4 mm	 118°			3/16 - 1 1/8"	101 70x	85
	HSSE Co5	Blank		 4 mm	 118°			3/16 - 1 1/8"	101 70x E	
	HSS	TiN		 4 mm	 118°			3/16 - 1 1/8"	101 70x T	
	HSS	TiAlN		 4 mm	 118°			3/16 - 1 1/8"	101 70x F	
	HSS	Blank		 4 mm	 118°			4,0 - 30,0	101 35x	86
	HSS	TiN		 4 mm	 118°			4,0 - 30,0	101 35x T	

Baustahl < 900 N/mm <sup>2</sup>	Inox <1100 N/mm <sup>2</sup>	Hochfester Stahl <1300 N/mm <sup>2</sup>	Messing	Bronze	Guss	Aluminium	Kunststoffe
●	●	○	●	○	○	●	●
●	●		●	○	○	●	●
●			●	○	○	●	●
●			●			●	●
●	●		●	●	●	○	○
●			●	●	●	○	○
●	●		●	●	●	○	○
●					●	○	○
●	●		●	●	●	○	○
●	●	○	○	●	●	○	○
●				○	●	○	○
●	○	○	○	○	●	○	○
●				○	●	○	○
●	○	○	○	○	●	○	○
●				●	●	○	○
●	●		●	●	●	○	○
●	○		○		●	○	○
●	●	○	○	●	●	○	○
●	●	○	○	●	●	●	○
●				●	●	○	○



# Typen- und Anwendungsübersicht

04

	Werkstoff	Oberfläche	Schneiden	Materialstärke	Spitzenwinkel	Spitzenanschliff	Schaft	Ø mm	Art.-Nr.	Seite/n
	HSS	Blank						5,3 – 32,5	101 09x	87
	HSS	TiN						5,3 – 32,5	101 09x T	
	HSS	TiAlN						5,3 – 32,5	101 09x F	
	HSS	Blank						12,0 – 40,0	101 36x	87
	HSS	VAP						M3 – M12	102 6xx	88
	HSS	VAP							102 6xx	89



Baustahl < 900 N/mm <sup>2</sup>	Inox <1100 N/mm <sup>2</sup>	Hochfester Stahl <1300 N/mm <sup>2</sup>	Messing	Bronze	Guss	Aluminium	Kunststoffe
●				●	●	○	○
●	○		○		●	○	○
●	●	○	○	●	●	○	○
●				●	●	○	○
●			●	○	○	●	●
●			●	○	○	●	●



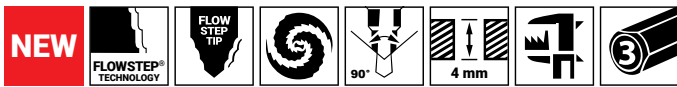

**ULTIMATECUT®**

## ULTIMATECUT Stufenbohrer HSSE-Co 5, spiralgenutet mit FLOWSTEP® Spitze

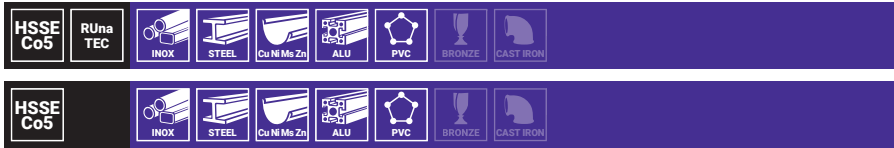

04

### FLOWSTEP® Spitze

- Perfektes Zentrieren ohne Ankören auch auf runden Oberflächen wie z. B. Rohren.
- Leichter und ruhiger Bohrvorgang, ohne verkanten im Material.
- Extrem schnelles und kräfteschonendes Bohren.
- Zeitersparnis beim Bohren von bis zu 75 %.
- Deutlich längere Standzeit - bis zu 6x mehr Bohrungen möglich.
- Optimal geeignet für den Einsatz in handgeführten (Akku-) Elektro-Werkzeugen.

Verpackung: Kunststoff

Größe Nr.	Ø1 - Ø2 mm	L1 mm	Stufenanzahl	Ø3 mm	HSSE-Co 5		HSSE-Co 5 RUnATEC	
0/9	5.0 - 12.0	66.0	8	6.0	101 650-9 E	1	101 650-9 EP	1
1	6.0 - 20.0	70.0	8	8.0	101 651 E	1	101 651 EP	1
2	8.0 - 30.0	95.0	12	10.0	101 652 E	1	101 652 EP	1
3	9.0 - 38.0	100.0	11	10.0	101 653 E	1	101 653 EP	1

Größe Nr.	Bohrbereich Ø mm
0/9	5.0   6.0   7.0   8.0   9.0   10.0   11.0   12.0 mm
1	6.0   8.0   10.0   12.0   14.0   16.0   18.0   20.0 mm
2	8.0   10.0   12.0   14.0   16.0   18.0   20.0   22.0   24.0   26.0   28.0   30.0 mm
3	9.0   13.0   16.0   19.0   21.0   23.0   26.0   29.0   32.0   35.0   38.0 mm

		HSSE-Co 5	HSSE-Co 5 RUnATEC
<b>3</b> tlg./pcs.	ULTIMATECUT Stufenbohrer-Sätze mit FLOWSTEP®-Spitze spiralgenutet in den Größen 0/9, 1, 2	101 626 ERO	101 626 EPRO





**ULTIMATECUT®**

## ULTIMATECUT Stufenbohrer HSS, spiralgenutet mit FLOWSTEP® Spitze

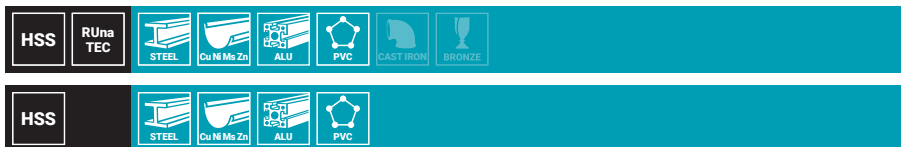

### FLOWSTEP® Spitze

- Perfektes Zentrieren ohne Ankören auch auf runden Oberflächen wie z. B. Rohren.
- Leichter und ruhiger Bohrvorgang, ohne verkanten im Material.
- Extrem schnelles und kräfteschonendes Bohren.
- Zeitersparnis beim Bohren von bis zu 75 %.
- Deutlich längere Standzeit - bis zu 6x mehr Bohrungen möglich.
- Optimal geeignet für den Einsatz in handgeführten (Akku-) Elektro-Werkzeugen.

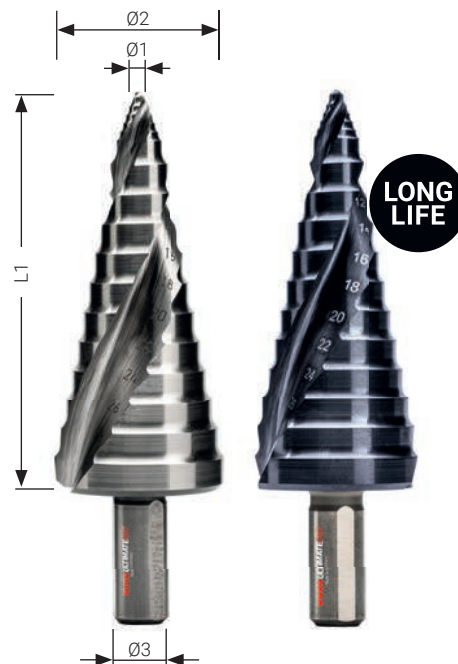

Verpackung: Kunststoff

Größe Nr.	Ø1 - Ø2 mm	L1 mm	Stufenanzahl	Ø3 mm	HSS	HSS RUnaTEC
0/9	5.0 - 12.0	66.0	8	6.0	101 650-9	101 650-9 P
1	6.0 - 20.0	70.0	8	8.0	101 651	101 651 P
2	8.0 - 30.0	95.0	12	10.0	101 652	101 652 P
3	9.0 - 38.0	1.30	38.0	16.0	101 653	101 653 P

Größe Nr.	Bohrbereich Ø mm
0/9	5.0   6.0   7.0   8.0   9.0   10.0   11.0   12.0 mm
1	6.0   8.0   10.0   12.0   14.0   16.0   18.0   20.0 mm
2	8.0   10.0   12.0   14.0   16.0   18.0   20.0   22.0   24.0   26.0   28.0   30.0 mm
3	9.0   13.0   16.0   19.0   21.0   23.0   26.0   29.0   32.0   35.0   38.0 mm

	HSS	HSS RUnaTEC
<b>3</b> tfg. pcs.	101 626 RO	101 626 PRO



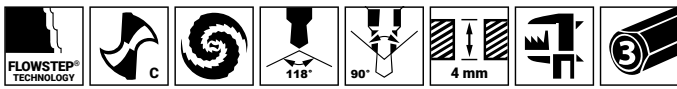

## Stufenbohrer HSS und HSSE-Co 5, spiralgutet

<b>HSSE Co5</b>	INOX	STEEL	Cu Ni Ms Zn	ALU	PVC	BRONZE	CAST IRON
<b>HSS TiAlN</b>	INOX	STEEL	Cu Ni Ms Zn	ALU	PVC	BRONZE	CAST IRON
<b>HSS TiN</b>	STEEL	Cu Ni Ms Zn	PVC	INOX	CAST IRON	BRONZE	
<b>HSS</b>	STEEL	Cu Ni Ms Zn	ALU	PVC	CAST IRON	BRONZE	



Der Stufenbohrer mit eigens entwickelter FLOWSTEP® Technologie ermöglicht nahtlose Übergang zwischen den verschiedenen Durchmessern. Jede einzelne Stufe verfügt über einen speziell entwickelten Hinterschliff, der den Stufenbohrer nach dem Durchbohren jeder Stufe nahtlos und kontrolliert auf die nächste Stufe führt. Das ermöglicht einen spürbaren und wesentlich leichtgängigeren und ruhigeren Bohrvorgang. Die tiefgeschliffene und spiralförmige Spannute bietet absolute Laufruhe und hohe Schnittleistung.

Insbesondere nicht brechende Späne werden wie bei einem Spiralbohrer sauber abtransportiert. Dies vermindert die Bildung von Aufbauschneiden und Kaltverschweißungen an den Schneiden. Der Konus erleichtert das Zurückziehen bei durchgebohrten Blechen.

Verpackung: Kunststoff

Größe Nr.	Ø1 - Ø2 mm	L1 mm	Stufenanzahl	Ø3 mm	HSSE-Co 5	HSS TiAlN	HSS TiN	HSS	
0/5	4.0 - 12.0	65.0	5	6.0	—	101 050-5 F	101 050-5 T	101 050-5	1
0/9	4.0 - 12.0	65.0	9	6.0	101 050-9 E	101 050-9 F	101 050-9 T	101 050-9	1
1	4.0 - 20.0	75.0	9	8.0	101 051 E	101 051 F	101 051 T	101 051	1
2	4.0 - 30.0	100.0	14	10.0	101 052 E	101 052 F	101 052 T	101 052	1
3	6.0 - 38.0	100.0	12	10.0	—	101 053 F	101 053 T	101 053	1
4	6.0 - 26.75	75.0	8	10.0	—	101 055 F	101 055 T	101 055	1
5	4.0 - 39.0	107.0	13	10.0	101 056 E	101 056 F	101 056 T	101 056	1
6	6.0 - 32.0	75.0	8	10.0	—	101 057 F	101 057 T	101 057	1
7	5.0 - 28.0	69.0	7	10.0	—	101 058 F	101 058 T	101 058	1
8	6.0 - 30.5	80.0	9	10.0	—	101 098 F	101 098 T	101 098	1
9	6.0 - 37.0	100.0	12	10.0	101 060 E	101 060 F	101 060 T	101 060	1
12	6.0 - 32.0	76.0	9	10.0	—	101 096 F	101 096 T	101 096	1
13	6.0 - 40.0	105.0	16	13.0	—	101 097 F*	101 097 T*	101 097*	1
18	6.5 - 32.5	91.0	12	10.0	101 534 E	—	—	—	1

\* gerade Nut

Größe Nr.	Bohrbereich Ø mm
0/5	4.0   6.0   8.0   10.0   12.0 mm
0/9	4.0   5.0   6.0   7.0   8.0   9.0   10.0   11.0   12.0 mm
1	4.0   6.0   8.0   10.0   12.0   14.0   16.0   18.0   20.0 mm
2	4.0   6.0   8.0   10.0   12.0   14.0   16.0   18.0   20.0   22.0   24.0   26.0   28.0   30.0 mm
3	6.0   9.0   13.0   16.0   19.0   21.0   23.0   26.0   29.0   32.0   35.0   38.0 mm
4	6.0   9.0   11.4 (PG7)   14.0 (PG9)   17.25 (PG11)   19.0 (PG13.5)   21.25 (PG16)   26.75 mm (PG21)
5	4.0   6.0   9.0   12.0   15.0   18.0   21.0   24.0   27.0   30.0   33.0   36.0   39.0 mm
6	6.0   9.0   11.2 (R1/8)   14.5 (R1/4)   18.2 (R3/8)   22.3 (R1/2)   27.9 (R3/4)   32.0 mm
7	5.0   8.8 (G1/8)   11.8 (G1/4)   15.3 (G3/8)   19.0 (G1/2)   24.5 (G3/4)   28.0 mm
8	6.0   9.0   12.5 (PG7)   15.2 (PG9)   18.6 (PG11)   20.4 (PG13.5)   22.5 (PG16)   28.3 (PG21)   30.5 mm
9	6.0   9.0   12.5 (PG7)   15.2 (PG9)   18.6 (PG11)   20.4 (PG13.5)   22.5 (PG16)   26.0   28.3 (PG21)   30.5   34.0   37.0 mm (PG29)
12	6.0   9.0   12.0   16.0   20.0   22.5   25.0   28.5   32.0 mm
13	6.0   11.0   17.0   23.0   29.0   30.0   31.0   32.0   33.0   34.0   35.0   36.0   37.0   38.0   39.0   40.0 mm
18	6.5   8.5   10.5   12.7   15.2 (PG9)   16.2   18.6 (PG11)   20.4 (PG13.5)   22.5 (PG16)   25.5   28.3 (PG21)   32.5 mm

		<b>HSS</b>	<b>HSSE-Co 5</b>	<b>HSS TiN</b>	<b>HSS TiAlN</b>
<b>3</b> tlg./pos.	Stufenbohrer-Satz spiralgenutet in den Größen 0/9, 1, 2	101 026 RO	101 026 ERO	101 026 TRO	101 026 FRO



101 026 RO



101 026 TRO



101 026 FRO

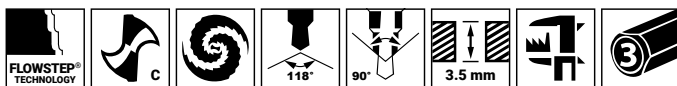

## Leitplankenstufenbohrer HSS TiAlN, spiralgenutet

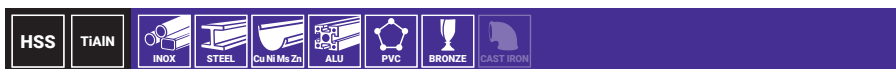

Speziell für Bohrungen von Leitplanken konzipiert.  
Einsatz bis 3,5 mm Materialstärke.  
Kühlung nicht notwendig aber empfehlenswert. (Standzeiterhöhung)

Verpackung: Kunststoff



Ø1 - Ø2 mm		L1 mm	Stufen- anzahl	Ø3 mm	<b>HSS TiAlN</b>	
6.0 - 18.0	6.0   8.0   10.0   12.0   14.0   16.0   18.0 mm	68,0	7	10,0	101 068 F-1	1

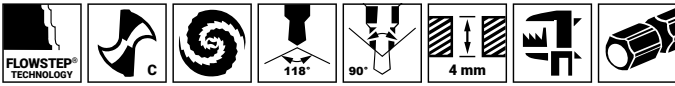

## Stufenbohrer-Bit HSS, spiralgenutet

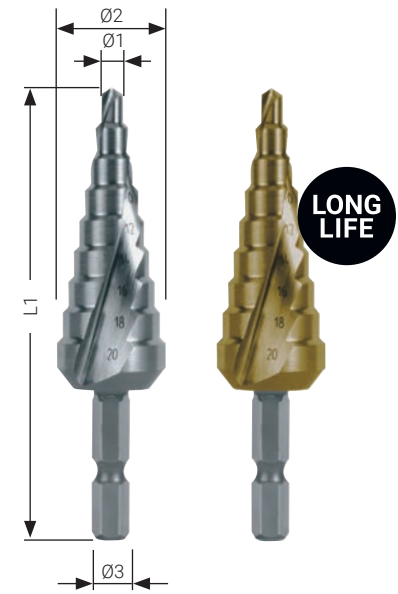
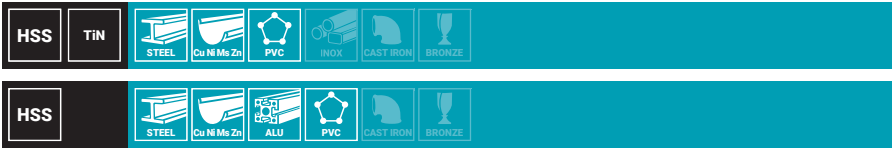

04

Die tiefgeschliffene und spiralförmige Spannute bietet absolute Laufruhe und hohe Schnittleistung. Insbesondere nicht brechende Späne werden wie bei einem Spiralbohrer sauber abtransportiert. Dies vermindert die Bildung von Aufbauschneiden und Kaltverschweißungen an den Schneiden. Der Konus erleichtert das Zurückziehen bei durchgebohrten Blechen.

Verpackung: Kunststoff

Größe Nr.	Ø1 - Ø2 mm	L1 mm	Stufenanzahl	Ø3 mm	Ø3 inch	HSS TiN	HSS	
0/9	4.0 - 12.0	72.0	9	6.35 x 27.0	1/4"	101 050-9 TH	101 050-9 H	1
1	4.0 - 20.0	81.0	9	6.35 x 27.0	1/4"	101 051 TH	101 051 H	1
2	4.0 - 30.0	105.0	14	6.35 x 27.0	1/4"	101 052 TH	101 052 H	1

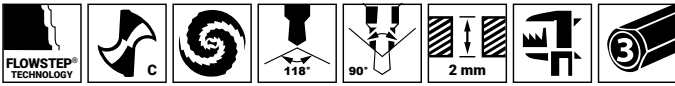

## Stufenbohrer HSS, spiralgenutet – kurz

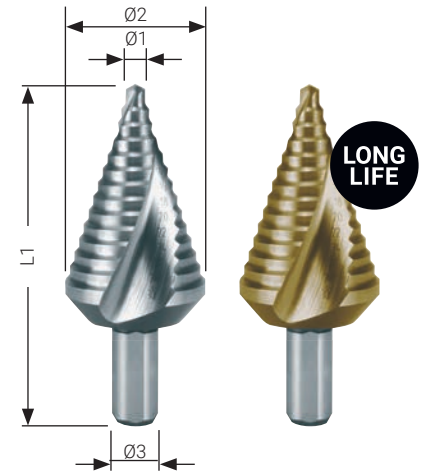

Verpackung: Kunststoff

Größe Nr.	Ø1 - Ø2 mm	L1 mm	Stufenanzahl	Ø3 mm	HSS TiN	HSS	
0/9k	4.0 - 12.0	48.0	9	6.0	101 061 T	101 061	1
1k	4.0 - 20.0	58.0	9	8.0	101 062 T	101 062	1
2k	4.0 - 30.0	72.0	14	10.0	101 063 T	101 063	1

Größe Nr.	Bohrbereich Ø mm
0/9	4.0   5.0   6.0   7.0   8.0   9.0   10.0   11.0   12.0 mm
1	4.0   6.0   8.0   10.0   12.0   14.0   16.0   18.0   20.0 mm
2	4.0   6.0   8.0   10.0   12.0   14.0   16.0   18.0   20.0   22.0   24.0   26.0   28.0   30.0 mm

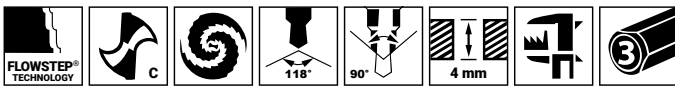

## Stufenbohrer HSS und HSSE-Co 5, spiralgenutet – Zollabmessungen

<b>HSSE Co5</b>	INOX	STEEL	Cu Ni Ms Zn	ALU	PVC	BRONZE	CAST IRON
<b>HSS TiAlN</b>	INOX	STEEL	Cu Ni Ms Zn	ALU	PVC	BRONZE	CAST IRON
<b>HSS TiN</b>	STEEL	Cu Ni Ms Zn	PVC	INOX	CAST IRON	BRONZE	
<b>HSS</b>	STEEL	Cu Ni Ms Zn	ALU	PVC	CAST IRON	BRONZE	

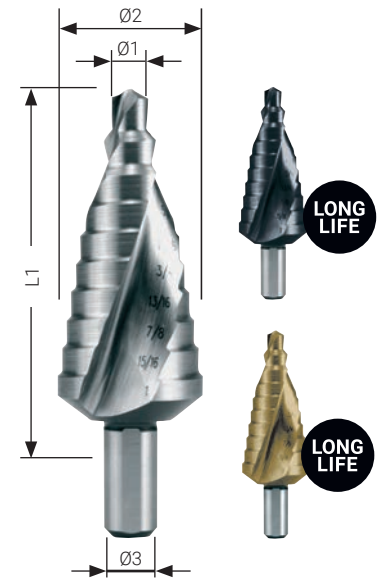

**Inch Size**

Die tiefgeschliffene und spiralförmige Spannute bietet absolute Laufruhe und hohe Schnittleistung. Insbesondere nicht brechende Späne werden wie bei einem Spiralbohrer sauber abtransportiert. Dies vermindert die Bildung von Aufbauschnitten und Kaltverschweißungen an den Schneiden. Der Konus erleichtert das Zurückziehen bei durchgebohrten Blechen.

Verpackung: Kunststoff

Größe Nr.	Ø1 - Ø2 inch	L1 inch	Stufenanzahl	Ø3 inch	HSSE-Co 5	HSS TiAlN	HSS TiN	HSS	
1	3/16" - 1/2"	3 1/8"	6	1/4"	101 701 E	101 701 F	101 701 T	101 701	1
2	1/8" - 1/2"	3 1/8"	13	1/4"	101 702 E	101 702 F	101 702 T	101 702	1
3	1/4" - 3/4"	2 3/4"	9	3/8"	101 703 E	101 703 F	101 703 T	101 703	1
4	3/16" - 7/8"	3 1/4"	12	3/8"	101 704 E	101 704 F	101 704 T	101 704	1
5	5/16" - 1"	3 1/4"	9	3/8"	101 705 E	101 705 F	101 705 T	101 705	1
6	7/8" - 1 3/8"	3 1/4"	5	3/8"	101 706 E	101 706 F	101 706 T	101 706	1
7	3/8" - 1/2"	1 7/8"	2	1/4"	101 707 E	101 707 F	101 707 T	101 707	1
8	7/8"	2 19/32"	1	3/8"	101 708 E	101 708 F	101 708 T	101 708	1
9	7/8" - 1 1/8"	3 7/64"	2	3/8"	101 709 E	101 709 F	101 709 T	101 709	1

Größe Nr.	Bohrbereich Ø inch
1	3/16"   1/4"   5/16"   3/8"   7/16"   1/2"
2	1/8"   5/32"   3/16"   7/32"   1/4"   9/32"   5/16"   11/32"   3/8"   19/32"   3/16"   15/32"   1/2"
3	1/4"   5/16"   3/8"   7/16"   1/2"   9/16"   5/8"   11/16"   3/4"
4	3/16"   1/4"   5/16"   3/8"   7/16"   1/2"   9/16"   5/8"   11/16"   3/4"   13/16"   7/8"
5	5/16"   1/2"   9/16"   5/8"   11/16"   3/4"   13/16"   7/8"   15/16"   1"
6	7/8"   1 1/8"   1 7/32"   1 1/4"   1 3/8"
7	3/8"   1/2"
8	7/8"
9	7/8"   1 1/8"

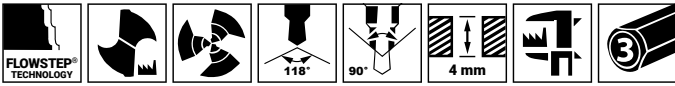

## Stufenbohrer HSS, mit 3 Schneiden, gerade Nut

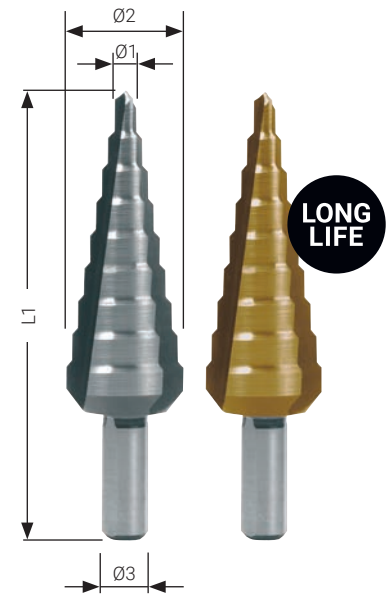
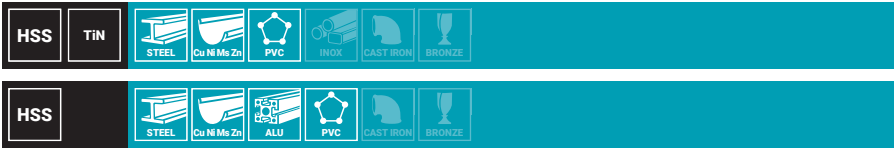

04

Die tiefgeschliffenen Spannuten bei Stufenbohrern mit 3 Schneiden gewährleisten ein absolut ratterfreies Arbeiten. Durch die geringere Schneidenbelastung ist ein höherer Vorschub insbesondere bei weichen Materialien wie NE-Metallen möglich. Der Konus erleichtert das Zurückziehen bei durchgebohrten Blechen.

Verpackung: Kunststoff

Größe Nr.	Ø1 - Ø2 mm	L1 mm	Stufenanzahl	Ø3 mm	HSS TiN	HSS	
0/9	4.0 - 12.0	65.0	9	6.0	101 350-9 T	101 350-9	1
1	4.0 - 20.0	75.0	9	8.0	101 351 T	101 351	1
2	4.0 - 30.0	100.0	14	10.0	101 352 T	101 352	1

Größe Nr.	Bohrbereich Ø mm
0/9	4.0   5.0   6.0   7.0   8.0   9.0   10.0   11.0   12.0 mm
1	4.0   6.0   8.0   10.0   12.0   14.0   16.0   18.0   20.0 mm
2	4.0   6.0   8.0   10.0   12.0   14.0   16.0   18.0   20.0   22.0   24.0   26.0   28.0   30.0 mm

		HSS TiN	HSS
<b>3</b> tfg./pcs.	Stufenbohrer-Satz mit 3 Schneiden in den Größen 0/9, 1, 2	101 326 TRO	101 326 RO





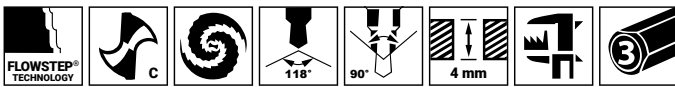

## Stufenbohrer HSS spiralgenutet, für metrische Kabelverschraubungen

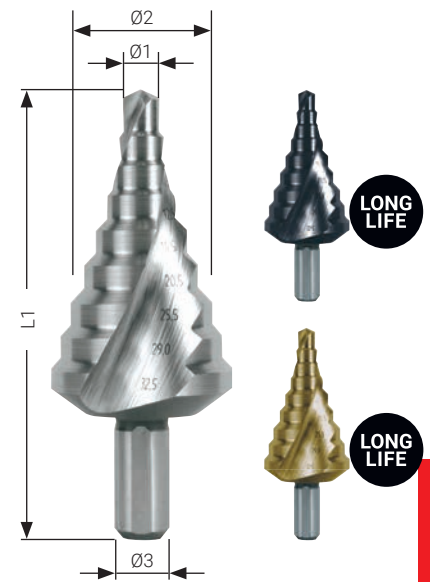
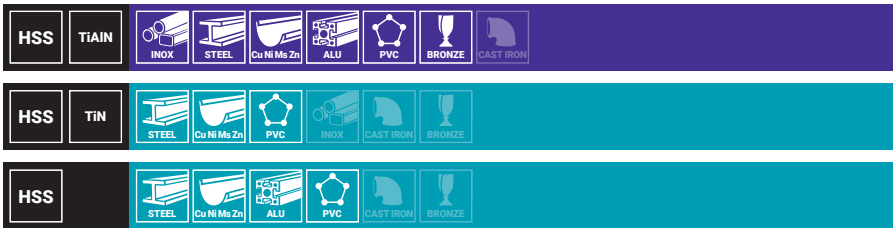

Verpackung: Kunststoff

Größe Nr.	Maße	Ø1 - Ø2 mm	L1 mm	Stufenanzahl	Ø3 mm	HSS TiAlN	HSS TiN	HSS	
14	Kernloch	5.3 - 30.5	79.0	9	10.0	101 093 F	101 093 T	101 093	1
15	Durchgang	6.5 - 32.5	79.0	9	10.0	101 092 F	101 092 T	101 092	1
16	Kernloch	5.3 - 38.5	96.0	11	10.0	101 091 F	101 091 T	101 091	1
17	Durchgang	6.5 - 40.5	96.0	11	10.0	101 090 F	101 090 T	101 090	1

14	DIN/EN 60423	5.3   7.0   9.0   10.5   14.5   18.5   23.5   27.0   30.5 mm
15	DIN/EN 50262	6.5   8.5   10.5   12.5   16.5   20.5   25.5   29.0   32.5 mm
16	DIN/EN 60423	5.3   7.0   9.0   10.5   14.5   18.5   23.5   27.0   30.5   34.5   38.5 mm
17	DIN/EN 50262	6.5   8.5   10.5   12.5   16.5   20.5   25.5   29.0   32.5   36.5   40.5 mm



## Stufenbohrer (Aufbohrer) HSS ohne Spitze



Verpackung: Kunststoff



Größe Nr.	Ø1 - Ø2 mm	L1 mm	Stufenanzahl	Ø3 mm	HSS	
20	12.0 - 20.0	66.0	9	8.0	101 361	1
30	20.0 - 30.0	78.0	11	10.0	101 362	1
40	30.0 - 40.0	78.0	11	10.0	101 363	1

Größe Nr.	Bohrbereich Ø mm
20	12.0   13.0   14.0   15.0   16.0   17.0   18.0   19.0   20.0 mm
30	20.0   21.0   22.0   23.0   24.0   25.0   26.0   27.0   28.0   29.0   30.0 mm
40	30.0   31.0   32.0   33.0   34.0   35.0   36.0   37.0   38.0   39.0   40.0 mm

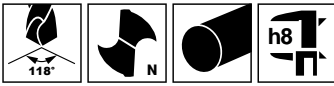

## Mehrfasenstufenbohrer Typ N HSS



Die Bohrung und Senkung wird in einem Arbeitsgang gefertigt.  
Hinweis: Die Schnittgeschwindigkeit nach dem großen Durchmesser und den Vorschub nach dem kleinen Durchmesser einstellen.

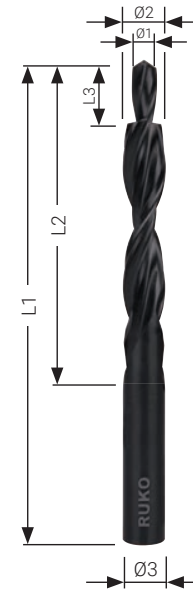

Verpackung: Kunststoff



## 90° Gütegrad fein für Durchgangsloch

Zum rationellen Erstellen von Durchgangsbohrungen und Schraubenkopfsenkungen mit 90°.

für Gewinde	Ø1 mm	Ø2 / Ø3 mm	L3 mm	L2 mm	L1 mm	HSS	
M 3	3.2	6.0	9.0	57.0	93.0	102 601	1
M 4	4.3	8.0	11.0	75.0	117.0	102 602	1
M 5	5.3	10.0	13.0	87.0	133.0	102 603	1
M 6	6.4	11.5	15.0	94.0	142.0	102 604	1
M 8	8.4	15.0	19.0	114.0	169.0	102 605	1
M 10	10.5	19.0	23.0	135.0	198.0	102 606	1



## 180° Gütegrad mittel für Durchgangsloch

Zum rationellen Erstellen von Durchgangsbohrungen und Schraubenkopfsenkungen mit 180°.

für Gewinde	Ø1 mm	Ø2 / Ø3 mm	L3 mm	L2 mm	L1 mm	HSS	
M 3	3.4	6.0	9.0	57.0	93.0	102 607	1
M 4	4.5	8.0	11.0	75.0	117.0	102 608	1
M 5	5.5	10.0	13.0	87.0	133.0	102 609	1
M 6	6.6	11.0	15.0	94.0	142.0	102 610	1
M 8	9.0	15.0	19.0	114.0	169.0	102 611	1
M 10	11.0	18.0	23.0	130.0	191.0	102 612	1



## 90° für Gewindekernloch

Zum rationellen Erstellen von Gewindekernbohrungen und Freisenkungen mit 90°.

für Gewinde	Ø1 mm	Ø2 / Ø3 mm	L3 mm	L2 mm	L1 mm	HSS	
M 3	2.5	3.4	8.8	39.0	70.0	102 613	1
M 4	3.3	4.5	11.4	47.0	80.0	102 614	1
M 5	4.2	5.5	13.6	57.0	93.0	102 615	1
M 6	5.0	6.6	16.5	63.0	101.0	102 616	1
M 8	6.8	9.0	21.0	81.0	125.0	102 617	1
M 10	8.5	11.0	25.5	94.0	142.0	102 618	1
M 12	10.2	13.5	30.0	108.0	160.0	102 619	1

## Kurzstufenbohrer Typ N HSS

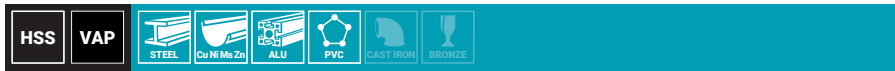

Kurzer und torsionsstabiler Bohrer, geeignet für den Einsatz auf CNC- bzw. NC-Maschinen. Die Bohrung und Senkung wird in einem Arbeitsgang gefertigt. Hinweis: Die Schnittgeschwindigkeit nach dem großen Durchmesser und den Vorschub nach dem kleinen Durchmesser einstellen.

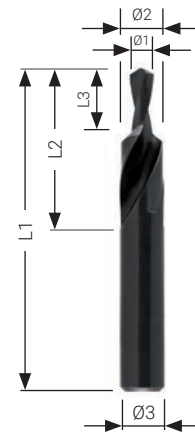

Verpackung: Kunststoff



### 90° Gütegrad fein für Durchgangsloch

Zum rationellen Erstellen von Durchgangsbohrungen und Schraubenkopfsenkungen mit 90°.

für Gewinde	Ø1 mm	Ø2 / Ø3 mm	L3 mm	L2 mm	L1 mm	HSS	
M 3	3,2	6,0	9,0	28,0	66,0	102 620	1
M 4	4,3	8,0	11,0	37,0	79,0	102 621	1
M 5	5,3	10,0	13,0	43,0	89,0	102 622	1
M 6	6,4	11,5	15,0	47,0	95,0	102 623	1
M 8	8,4	15,0	19,0	56,0	111,0	102 624	1
M 10	10,5	19,0	23,0	64,0	127,0	102 625	1



### 180° Gütegrad mittel für Durchgangsloch

Zum rationellen Erstellen von Durchgangsbohrungen und Schraubenkopfsenkungen mit 180°.

für Gewinde	Ø1 mm	Ø2 / Ø3 mm	L3 mm	L2 mm	L1 mm	HSS	
M 3	3,4	6,0	9,0	28,0	66,0	102 626	1
M 4	4,5	8,0	11,0	37,0	79,0	102 627	1
M 5	5,5	10,0	13,0	43,0	89,0	102 628	1
M 6	6,6	11,0	15,0	47,0	95,0	102 629	1
M 8	9,0	15,0	19,0	56,0	111,0	102 630	1
M 10	11,0	18,0	23,0	62,0	123,0	102 631	1



### 90° für Gewindekernloch

Zum rationellen Erstellen von Gewindekernbohrungen und Freisenkungen mit 90°.

für Gewinde	Ø1 mm	Ø2 / Ø3 mm	L3 mm	L2 mm	L1 mm	HSS	
M 3	2,5	3,4	8,8	20,0	52,0	102 632	1
M 4	3,3	4,5	11,4	24,0	58,0	102 633	1
M 5	4,2	5,5	13,6	28,0	66,0	102 634	1
M 6	5,0	6,6	16,5	31,0	70,0	102 635	1
M 8	6,8	9,0	21,0	40,0	84,0	102 636	1
M 10	8,5	11,0	25,5	47,0	95,0	102 637	1
M 12	10,2	13,5	30,0	54,0	107,0	102 638	1

# Drehzahltablelle für Stufenbohrer

Material:		unleg. Baustahl bis 700 N/mm <sup>2</sup>	unleg. Baustahl über 700 N/mm <sup>2</sup>	legierte Stähle bis 1000 N/mm <sup>2</sup>	Gußeisen bis 250 N/mm <sup>2</sup>	Gußeisen über 250 N/mm <sup>2</sup>	CuZn- Legierung spröde	CuZn- Legierung zäh	Al- Legierung bis 11% Si	Thermo- plaste	Duro- plaste
Blechstärke in mm:		bis 4.0	bis 4.0	bis 4.0	bis 4.0	bis 4.0	bis 4.0	bis 4.0	bis 4.0	bis 4.0	bis 4.0
Vc = m/min		30	20	20	15	10	60	35	30	20	15
Kühlschmierstoff:		Schneid- spray	Schneid- spray	Schneid- spray	Druckluft	Druckluft	Druckluft	Druckluft	Schneid- spray	Wasser	Druckluft
Größe Nr.	Ø mm	U/min	U/min	U/min	U/min	U/min	U/min	U/min	U/min	U/min	U/min
0/5	4.0 - 12.0	800 - 2400	500 - 1600	500 - 1600	400 - 1200	300 - 800	1600 - 4800	900 - 2800	800 - 2400	500 - 1600	400 - 1200
0/9	4.0 - 12.0	800 - 2400	500 - 1600	500 - 1600	400 - 1200	300 - 800	1600 - 4800	900 - 2800	800 - 2400	500 - 1600	400 - 1200
1	4.0 - 20.0	500 - 2400	300 - 1600	300 - 1600	200 - 1200	200 - 800	1000 - 4800	600 - 2800	500 - 2400	300 - 1600	200 - 1200
2	4.0 - 30.0	300 - 2400	200 - 1600	200 - 1600	200 - 1200	100 - 800	600 - 4800	400 - 2800	300 - 2400	200 - 1600	200 - 1200
3	6.0 - 38.0	300 - 1600	200 - 1100	200 - 1100	100 - 800	100 - 500	500 - 3200	300 - 1900	300 - 1600	200 - 1100	100 - 800
4	6.0 - 26.8	400 - 1600	200 - 1100	200 - 1100	200 - 800	100 - 500	700 - 3200	400 - 1900	400 - 1600	200 - 1100	200 - 800
5	4.0 - 32.0	300 - 2400	200 - 1600	200 - 1600	1200 - 100	100 - 800	600 - 4800	300 - 2800	300 - 2400	200 - 1600	100 - 1200
6	6.0 - 32.0	300 - 1600	200 - 1100	200 - 1100	800 - 100	100 - 500	600 - 3200	300 - 1900	300 - 1600	200 - 1100	100 - 800
7	5.0 - 28.0	300 - 1900	200 - 1300	200 - 1300	200 - 1000	100 - 600	700 - 3800	400 - 2200	300 - 1900	200 - 1300	200 - 1000
8	6.0 - 30.5	300 - 1600	200 - 1100	200 - 1100	200 - 800	100 - 500	600 - 3200	400 - 1900	300 - 1600	200 - 1100	200 - 800
9	6.0 - 37.0	300 - 1600	200 - 1100	200 - 1100	100 - 800	100 - 500	500 - 3200	300 - 1900	300 - 1600	200 - 1100	100 - 800
10	4.8 - 10.7	900 - 2000	600 - 1300	600 - 1300	400 - 1000	300 - 700	1800 - 4000	1000 - 2300	900 - 2000	600 - 1300	400 - 1000
11	6.0 - 25.0	400 - 1600	300 - 1100	300 - 1100	200 - 800	100 - 500	800 - 3200	400 - 1900	400 - 1600	300 - 1100	200 - 800
12	6.0 - 32.0	300 - 1600	200 - 1100	200 - 1100	100 - 800	100 - 500	600 - 3200	300 - 1900	300 - 1600	200 - 1100	100 - 800
13	6.0 - 40.0	200 - 1600	200 - 1100	200 - 1100	100 - 800	100 - 500	500 - 3200	300 - 1900	200 - 1600	200 - 1100	100 - 800
14	5.3 - 30.5	300 - 1800	200 - 1200	200 - 1200	200 - 900	100 - 600	600 - 3600	400 - 2100	300 - 1800	200 - 1200	200 - 900
15	6.5 - 32.5	300 - 1500	200 - 1000	200 - 1000	100 - 700	100 - 500	600 - 2900	300 - 700	300 - 1500	200 - 1000	100 - 700
16	5.3 - 38.5	200 - 1800	200 - 1200	200 - 1200	100 - 900	100 - 600	500 - 3600	300 - 2100	200 - 1800	200 - 1200	100 - 900
17	6.5 - 40.5	200 - 1500	200 - 1000	200 - 1000	100 - 700	100 - 500	500 - 2900	300 - 1700	200 - 1500	200 - 1000	100 - 700
18	6.5 - 32.5	300 - 1500	200 - 1000	200 - 1000	100 - 700	100 - 500	600 - 2900	300 - 1700	300 - 1500	200 - 1000	100 - 700
20	12.0 - 20.0	500 - 800	300 - 500	300 - 500	200 - 400	200 - 300	600 - 1600	600 - 900	500 - 800	300 - 500	200 - 400
30	20.0 - 30.0	300 - 500	200 - 300	200 - 300	200 - 200	100 - 200	600 - 1000	400 - 600	300 - 500	200 - 300	200 - 200
40	30.0 - 40.0	200 - 300	200 - 200	200 - 200	100 - 200	100 - 100	500 - 600	300 - 400	200 - 300	200 - 200	100 - 200
Größe Nr.	Ø Zoll	U/min	U/min	U/min	U/min	U/min	U/min	U/min	U/min	U/min	U/min
1	3/16 - 1/2	800 - 2000	500 - 1300	1300 - 500	400 - 1000	300 - 700	1500 - 4000	900 - 2300	800 - 2000	500 - 1300	400 - 1000
2	1/8 - 1/2	800 - 3000	500 - 2000	2000 - 500	400 - 1500	300 - 1000	1500 - 6000	900 - 3500	800 - 3000	500 - 2000	400 - 1500
3	1/4 - 3/4	500 - 1500	300 - 1000	1000 - 300	300 - 800	200 - 500	1000 - 3000	600 - 1800	500 - 1500	300 - 1000	300 - 800
4	3/16 - 7/8	400 - 2000	300 - 1300	1300 - 300	200 - 1000	100 - 700	900 - 4000	500 - 2300	400 - 2000	300 - 1300	200 - 1000
5	5/16 - 1	400 - 1200	300 - 800	800 - 300	200 - 600	100 - 400	800 - 2400	400 - 1400	400 - 1200	300 - 800	200 - 600
6	7/8 - 1 3/8	300 - 400	200 - 300	300 - 200	100 - 200	100 - 100	500 - 900	300 - 500	300 - 400	200 - 300	100 - 200
7	3/8 - 1/2	800 - 1000	500 - 700	700 - 500	400 - 500	300 - 300	1500 - 2000	900 - 1200	800 - 1000	500 - 700	400 - 500
8	7/8	400	300	300	200	100	900	500	400	300	200
9	7/8 - 1 1/8	300 - 400	200 - 300	300 - 200	200 - 200	100 - 100	700 - 900	400 - 500	300 - 400	200 - 300	200 - 200



# Anwendungstabelle für Stufenbohrer

Größe Nr.	Bohrbereiche mm													
0/5	Für metrische Lochmaße													
	Ø 4.0	Ø 6.0	Ø 8.0	Ø 10.0	Ø 12.0									
0/9	Für metrische Lochmaße													
	Ø 4.0	Ø 5.0	Ø 6.0	Ø 7.0	Ø 8.0	Ø 9.0	Ø 10.0	Ø 11.0	Ø 12.0					
1	Für metrische Lochmaße													
	Ø 4.0	Ø 6.0	Ø 8.0	Ø 10.0	Ø 12.0	Ø 14.0	Ø 16.0	Ø 18.0	Ø 20.0					
2	Für metrische Lochmaße													
	Ø 4.0	Ø 6.0	Ø 8.0	Ø 10.0	Ø 12.0	Ø 14.0	Ø 16.0	Ø 18.0	Ø 20.0	Ø 22.0	Ø 24.0	Ø 26.0	Ø 28.0	Ø 30.0
3	Für metrische Lochmaße													
	Ø 6.0	Ø 9.0	Ø 13.0	Ø 16.0	Ø 19.0	Ø 21.0	Ø 23.0	Ø 26.0	Ø 29.0	Ø 32.0	Ø 35.0	Ø 38.0		
4	Für Panzerrohrgewinde Kernlochmaße													
	PG 7 / Ø 11.4		PG 9 / Ø 14.0		PG 11 / Ø 17.25		PG 13.5 / Ø 19.0		PG 16 / Ø 21.25		PG 21 / Ø 26.75			
5	Für metrische Lochmaße													
	Ø 4.0	Ø 6.0	Ø 9.0	Ø 12.0	Ø 15.0	Ø 18.0	Ø 21.0	Ø 24.0	Ø 27.0	Ø 30.0	Ø 33.0	Ø 36.0	Ø 39.0	
6	Für Rohrgewinde Außen-Ø Durchgangsmaße													
	R 1/8" / Ø 11.2		R 1/4" / 14.5		R 3/8" / Ø 18.2		R 1/2" / Ø 22.3		R 3/4" / Ø 27.9					
7	Für Rohrgewinde Kernlochmaße													
	G 1/8" / Ø 8.8		G 1/4" / 11.8		G 3/8" / Ø 15.3		G 1/2" / Ø 19.0		G 3/4" / Ø 24.5					
8	Für Panzerrohrgewinde Durchgangsmaße													
	PG 7 / Ø 12.5		PG 9 / Ø 15.2		PG 11 / Ø 18.6		PG 13.5 / Ø 20.4		PG 16 / Ø 22.5		PG 21 / Ø 28.3			
9	Für Panzerrohrgewinde Durchgangsmaße													
	PG 7 / Ø 12.5		PG 9 / Ø 15.2		PG 11 / Ø 18.6		PG 13.5 / Ø 20.4		PG 16 / Ø 22.5		PG 21 / Ø 28.3		PG 29 / Ø 37.0	
10	Für Blindnietmuttern M3 - M4 - M5 - M6 - M8													
	Ø 4.8	Ø 6.4	Ø 7.2	Ø 9.6	Ø 10.65									
11	Für metrische Lochmaße mit extra hohen Stufen													
	Ø 6.0	Ø 9.0	Ø 12.0	Ø 16.0	Ø 20.0	Ø 22.5	Ø 25.0							
12	Für metrische Lochmaße mit extra hohen Stufen													
	Ø 6.0	Ø 9.0	Ø 12.0	Ø 16.0	Ø 20.0	Ø 22.5	Ø 25.0	Ø 28.5	Ø 32.0					
13	Für metrische Lochmaße und großen Durchmesser													
	Ø 6.0	Ø 11.0	Ø 17.0	Ø 23.0	Ø 29.0	Ø 30.0	Ø 31.0	Ø 32.0	Ø 33.0	Ø 34.0	Ø 35.0	Ø 36.0	Ø 37.0	Ø 38.0
14	Für metrische Kabelverschraubungen. Kernlochmaße nach DIN/EN 60423													
	M 6 Ø 5.3	M 8 Ø 7.0	M 10 Ø 9.0	M 12 Ø 10.5	M 16 Ø 14.5	M 20 Ø 18.5	M 25 Ø 23.5	M 32 Ø 30.5						
15	Für metrische Kabelverschraubungen. Durchgangsmaße nach DIN/EN 50262													
	M 6 Ø 6.5	M 8 Ø 8.5	M 10 Ø 10.5	M 12 Ø 12.5	M 16 Ø 16.5	M 20 Ø 20.5	M 25 Ø 25.5	M 32 Ø 32.5						
16	Für metrische Kabelverschraubungen. Kernlochmaße nach DIN/EN 60423													
	M 6 Ø 5.3	M 8 Ø 7.0	M 10 Ø 9.0	M 12 Ø 10.5	M 16 Ø 14.5	M 20 Ø 18.5	M 25 Ø 23.5	M 32 Ø 30.5	M 40 Ø 38.5					
17	Für metrische Kabelverschraubungen. Durchgangsmaße nach DIN/EN 50262													
	M 6 Ø 6.5	M 8 Ø 8.5	M 10 Ø 10.5	M 12 Ø 12.5	M 16 Ø 16.5	M 20 Ø 20.5	M 25 Ø 25.5	M 32 Ø 32.5	M 40 Ø 40.5					
18	Für metrische Kabelverschraubungen / Panzerrohrgewinde. Durchgangsmaße													
	M 6 Ø 6.5	M 8 Ø 8.5	M 10 Ø 10.5	M 12 / PG 7 Ø 12.7	PG 9 Ø 15.7	M 16 Ø 16.2	PG 11 Ø 18.6	M 20 / PG 13.5 Ø 20.4	PG 16 Ø 22.5	M 25 Ø 25.5	PG 21 Ø 28.3	M 32 Ø 32.5		



**ULTIMATECUT<sup>®</sup>**

# Multidrill mit Turbo-Spitze

**Er ist dein 5-in-1-Werkzeug.  
Er lässt dich 75 % schneller bohren.  
Er gibt dir ultimative Flexibilität.**



**RUKO** Turbo-Spitze

Punktgenaues Zentrieren = kein Ankörnen mehr nötig.  
Zeitersparnis durch schnelleres Anbohren = mehr Löcher in derselben Zeit bohren.

**RUna  
TEC**

### **RUKO RUnaTEC-Beschichtung**

Durch die RUKO nano Technology (RUnaTEC) können neben niedrigen vor allem sehr hohe Schnittgeschwindigkeiten gefahren und somit Arbeitsvorgänge deutlich beschleunigt werden.

Weitere positive Eigenschaften sind die extrem hohe Verschleißfestigkeit und die starke Reduzierung der Materialverschweißungen.

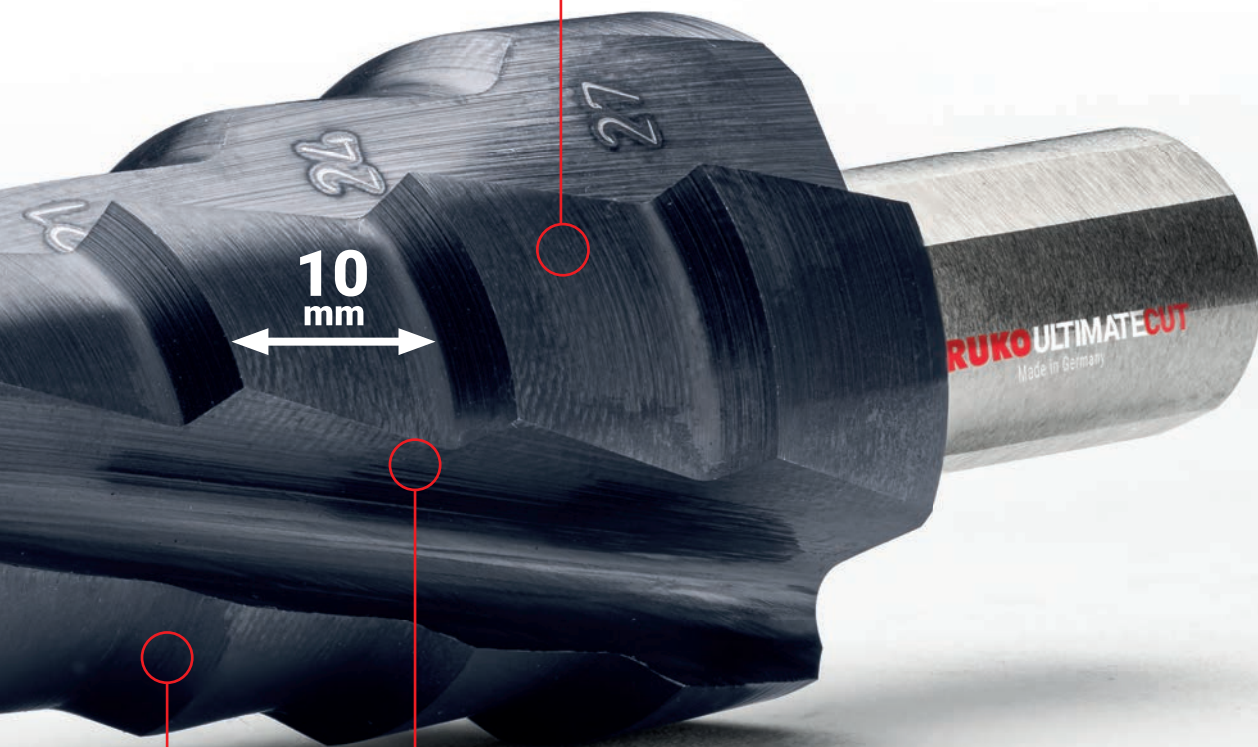

### **Der Alleskönner**

Wo Magnetbohrmaschinen mit geringer Haftkraft Probleme haben, bietet der ULTIMATECUT Multidrill durch den Einsatz in Handbohrmaschinen ultimative Flexibilität.

Zudem können schwer zugängliche Stellen wie z. B. T-Träger erreicht werden.



### **RUKO FLOWSTEP® Technologie**

Kontrollierbar bei empfindlichen Werkstoffen, wie dünnwandigen Blechen und Acrylglas.  
Kraftvoll bei zähen Werkstoffen, wie Edelstahl.

Die Schneidengeometrie ermöglicht einen weichen, nahtlosen Übergang zwischen den verschiedenen Durchmessern.

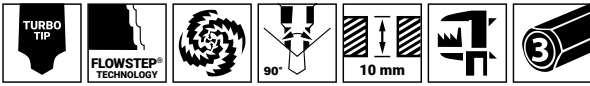

**ULTIMATECUT®**

## ULTIMATECUT Multidrill HSS RUnaTEC, spiralgenutet mit Turbo-Spitze



Der ULTIMATECUT Multidrill revolutioniert den Arbeitsprozess und setzt bei einer Zeitersparnis von bis zu 75 % neue Maßstäbe in der Bearbeitungszeit. Das erreicht der Stufenbohrer von RUKO durch seine revolutionäre Schneidengeometrie, indem er die unterschiedlichsten Anwendungen und Werkzeuge miteinander vereint. Das bedeutet weniger benötigte Werkzeuge, keine Werkzeugwechsel und absolute Flexibilität.

04



### Anwendungstipp

- Kühlen.
- Drehzahl anpassen.
- Geringe Drehzahlen beim Handbohrbetrieb (Handbohrmaschine).
- Drehzahltable für ULTIMATECUT Stufenbohrer beachten.
- Beim Bohren auf die Gesamtlänge des Stufenbohrers achten.



Verpackung: Kunststoff

Größe Nr.	Ø1 - Ø2 mm	Bohrbereich Ø mm	L1 mm	Stufenanzahl	Ø3 mm	HSS RUnaTEC	
S1	6.0 - 12.0	6.0   7.0   8.0   9.0   10.0   11.0   12.0 mm	105.0	7	8.0	101 082 P	1
M2	6.0 - 20.0	6.0   8.0   10.0   12.0   14.0   16.0   18.0   20.0 mm	120.0	8	10.0	101 083 P	1
L3	6.0 - 27.0	6.0   9.0   12.0   15.0   18.0   21.0   24.0   27.0 mm	125.0	8	12.0	101 084 P	1

		HSS RUnaTEC
<b>3</b> Stg./pcs.	ULTIMATECUT Multidrill-Satz spiralgenutet in den Größen S1, M2, L3	101 087 PRO



### Drehzahltable

Material	Anwendung	Arbeitsgang	Handbohrmaschine	Ständerbohrmaschine manueller Vorschub	Ständerbohr- / CNC-Maschine automatischer Vorschub
	Hauptanwendung	Anbohren (Durchbohren 1. Stufe)	bis 1000 U/min Kühlung empfohlen	bis 1000 U/min Kühlung empfohlen	ca. 750 U/min f = 0,1 mm/U Kühlung notwendig
		Aufbohren (ab 2. Stufe)	100-250 U/min Kühlung empfohlen	250-350 U/min Kühlung empfohlen	
	Nebenanwendung (bedingt geeignet)	Anbohren (Durchbohren 1. Stufe)	bis 600 U/min Kühlung notwendig	bis 600 U/min Kühlung notwendig	ca. 600 U/min f = 0,05 mm/U Kühlung notwendig
		Aufbohren (ab 2. Stufe)	100-200 U/min Kühlung notwendig	200-300 U/min Kühlung notwendig	





**05**

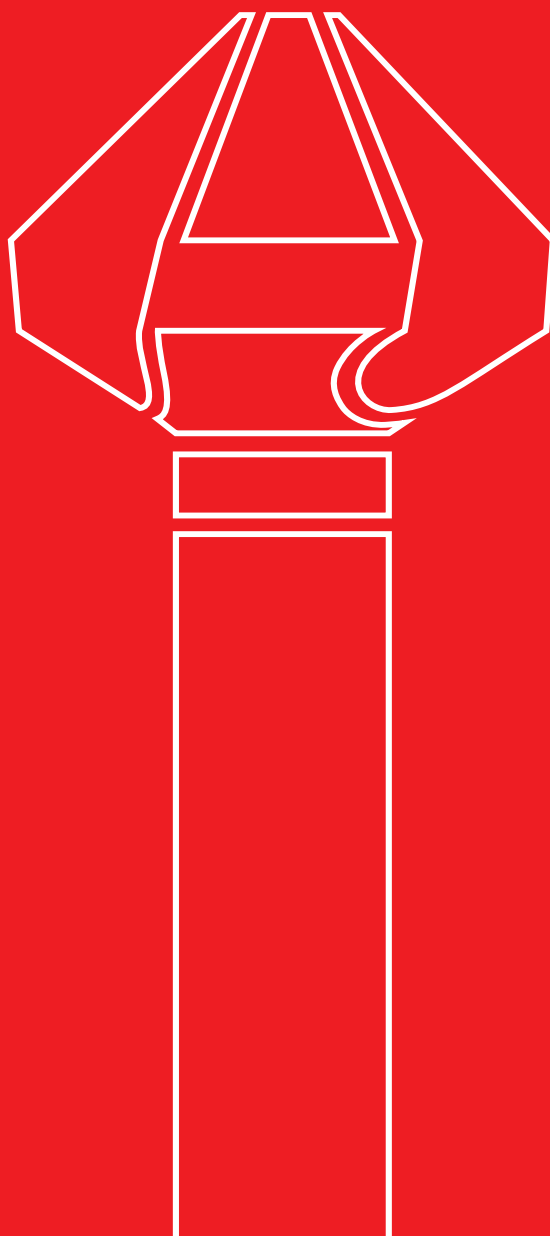

# SENKER

Typen- und Anwendungsübersicht	100 – 103
ULTIMATECUT Kegelsenker 4S HSSE-Co 5 + RUnATEC, ähnlich DIN 335, 90°	104
ULTIMATECUT Kegelsenker 4S HSS + RUnATEC, ähnlich DIN 335, 90°	105
ULTIMATECUT Kegelsenker HSSE-Co 5 + RUnATEC, DIN 335 Form C 90°	106
ULTIMATECUT Kegelsenker HSS + RUnATEC, DIN 335 Form C 90°	107
Kegelsenker DIN 335 Form C 90° HSS TiAlN + HSSE-Co 5 + Hartmetall	108 – 109
Kegelsenker DIN 335 Form C 90° HSS + TiN + ALU	110 – 111
Kegelsenker DIN 335 Form C 90° HSS mit langem Zylinderschaft	112
Kegelsenker DIN 335 Form D 90° HSS	113
Kegelsenker DIN 334 Form C 60° HSS	113
Kegelsenker DIN 334 Form D 60° HSS	114
Kegelsenker Form C 75° HSS	114
Kegelsenker Form D 75° HSS	115
Kegelsenker Form C 120° HSS	115
Kegelsenker Form D 120° HSS	116
Kegelsenker Form C 90° HSS	116
Kegelsenker Form C 82° HSS – <i>Zollabmessungen</i>	117
Kegelsenker-Bit 90° HSS + TiN – <i>kurz</i>	118
Kegelsenker-Bit 90° HSS + TiN – <i>lang</i>	119
Magnethalter mit 1/4" Sechskantaufnahme	119
Universalhandgriffe mit / ohne Senkwerkzeug	120
Querlochsinker 90° HSS + TiN + HSSE-Co 5	121
Flachsinker DIN 373 HSS + TiN mit Zylinderschaft und festem Führungszapfen	122 – 123
Senkungen nach DIN 74 Blatt 2	123
Flachsinker HSS mit Morsekegel und festem Führungszapfen	124
Drehzahlrichtwerte für Kegelsenker	125
Senkungen nach DIN 74 für Senkschrauben nach DIN	125

Schnell. Scharf. Stark. Sensationell.

**ULTIMATECUT<sup>®</sup>**

# Kegelsenker 4S – mit 4 Schneiden

Er lässt dich 3-mal mehr senken.  
Er macht dich doppelt so schnell.  
Er spart dir Kraft.

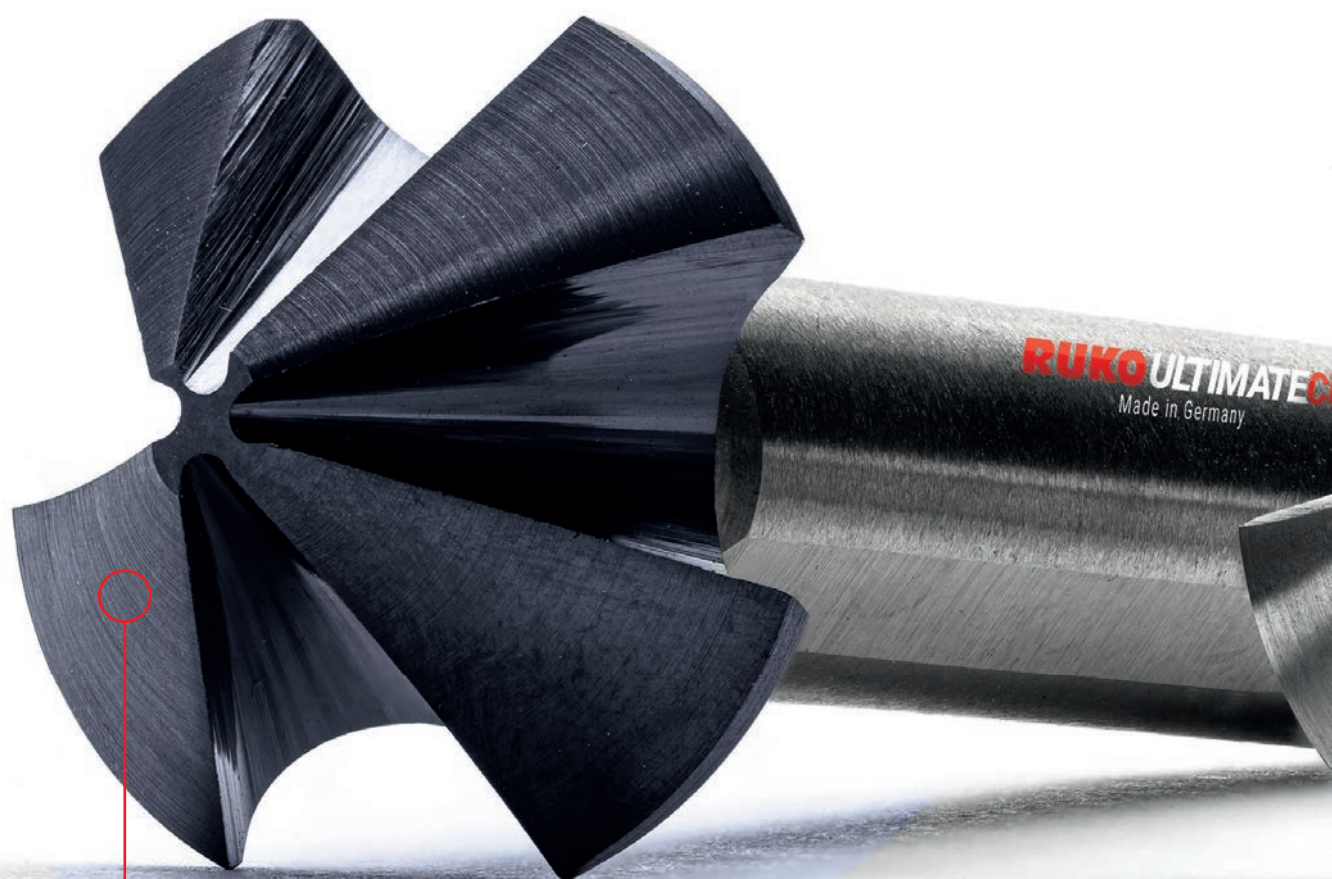

## **RUKO** 4 Schneiden + Ungleichteilung

Die Verteilung der einwirkenden Kräfte auf die vier Schneiden reduzieren spürbar die Axial- und Radialkräfte und garantieren über die Ungleichteilung einen extrem ruhigen und materialschonenden Lauf des Werkzeugs.



### Senken. Neu gedacht.















































































Erstmals können mit der neu entwickelten Schneidtechnologie sogar Senkungen mit Durchmesser bis 40 mm mit handgeführten Schraub- und Bohrwerkzeugen durchgeführt werden.



### Unvergleichbare Performance



































Die HSSE-Co 5 Variante erweitert das Anwendungsspektrum um die leistungsstarke Zerspanung von Edelstählen und anspruchsvollen Hardox-Stählen.

# Typen- und Anwendungsübersicht

	Werkstoff	Oberfläche	DIN	Typ	Senkwinkel	Schneiden	Schaft	Ø mm	Art.-Nr.	Sonstiges	Seite/n	
	<b>NEW</b> <b>ULTIMATECUT®</b>	HSS	Blank	DIN 335	C				10,4 – 40,0	102 7xx		105
	HSS	RUna TEC	DIN 335	C				102 7xx P				
	HSSE Co5	Blank	DIN 335	C				102 7xx E				
	HSSE Co5	RUna TEC	DIN 335	C				102 7xx EP		104		
	<b>ULTIMATECUT®</b>	HSS	Blank	DIN 335	C				6,3 – 31,0	102 7xx		107
	HSS	RUna TEC	DIN 335	C				102 7xx P				
	HSSE Co5	Blank	DIN 335	C				102 7xx E				
	HSSE Co5	RUna TEC	DIN 335	C				102 7xx EP		106		
	HSS	Blank	DIN 335	C				4,3 – 40,0	102 1xx		108 – 111	
	HSS	Blank	DIN 335	C				6,3 – 31,0	102 1xx A	<b>ALU</b>		
	HSSE Co5	Blank	DIN 335	C				4,3 – 31,0	102 1xx E			
	HSS	TiN	DIN 335	C				4,3 – 40,0	102 1xx T			
	HSS	TiAlN	DIN 335	C				4,3 – 40,0	102 1xx F			
	TC HM	Blank	DIN 335	C				6,3 – 31,0	102 26x			
	HSS	Blank	DIN 335	C				6,3 – 25,0	102 2xx		112	
	HSS	Blank	DIN 335	D				15,0 – 80,0	102 1xx		113	
	HSS	Blank	DIN 334	C				6,3 – 25,0	102 201 - 102 207		113	
	HSS	Blank	DIN 334	D				16,0 – 80,0	102 208 - 102 215		114	
	HSS	Blank		C				6,3 – 25,0	102 221 - 102 227		114	
	HSS	Blank		D				16,5 – 40,0	102 228 - 102 232		115	
	HSS	Blank		C				6,3 – 25,0	102 241 - 102 247		115	
	HSS	Blank		D				16,5 – 40,0	102 2xx		116	



# Typen- und Anwendungsübersicht

	Werkstoff	Oberfläche	DIN	Form	Senkwinkel	Schneiden	Schaft	Ø mm	Art.-Nr.	Sonstiges	Seite/n
	HSS	Blank		C	90°			6,0 – 50,0	102 5xx		116
	HSS	Blank	DIN 335	C	82°			1/4 – 1 Inch	102 182 - 102 191	Inch Size	117
	HSS	Blank			90°			6,3 – 20,5	W102 31x		118
	HSS	TiN			90°			6,3 – 20,5	W102 31x T		
	HSS	Blank			90°			6,3 – 20,5	102 31x		119
	HSS	TiN			90°			6,3 – 20,5	102 31x T		
	HSS	Blank			90°			12,4 – 25,0	102 14x	mit Handgriff	120
	HSS	Blank			90°			2,0 – 25,0	102 30x		121
	HSSE Co5	Blank			90°			1,0 – 25,0	102 30x E		
	HSS	TiN			90°			2,0 – 25,0	102 30x T		
	HSS	Blank			180°			M3 – M12	102 4xx		122 – 123
	HSS	TiN			180°			M3 – M12	102 4xx T		
	HSS	Blank			180°			M10 – M22	102 4xx		124

05



## Anwendungstipp

Um die Standzeit zu erhöhen, Drehzahl reduzieren. Kühlen beim Senken.





Baustahl < 900 N/mm <sup>2</sup>	Edelstahl < 1100 N/mm <sup>2</sup>	Titan legiert < 1300 N/mm <sup>2</sup>	Messing	Bronze	Guss	Aluminium	Kunststoffe
●			●	○	○	●	○
●	●		●	○	●	●	○
●			●	○	○	●	○
●	○		●	○	○		○
●			●	○	○	●	○
●	○		●	○	○		○
●			●			●	○
●			●	○	○	●	○
●	●		●	○	○	●	○
●	○		●	○	○		○
●			●	○	○	●	○
●	○		●	○	○		○
●			●	○	○	●	○



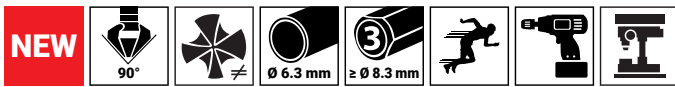

**ULTIMATECUT®**

## ULTIMATECUT Kegelsenker 4S HSSE-Co 5, ähnlich DIN 335, 90°

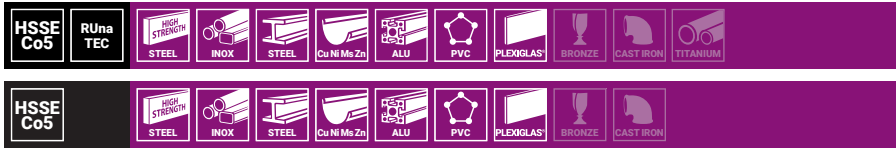

Der ULTIMATECUT Kegelsenker 4S ist ein Hochleistungswerkzeug, das für beste Performance in allen Disziplinen steht. Optimal einsetzbar sind die ULTIMATECUT Kegelsenker 4S in handgeführten Anwendungen mit dem Akku-Schrauber, einer Bohrmaschine oder in Ständerbohrmaschinen.



**05**

**!** 4 Schneiden aus technischen Gründen ab Ø 10,4 mm, kleinere Abmessungen in Ausführungen mit 3 Schneiden.

Verpackung: Kunststoff

Ø2 mm	Ø1 mm	L1 mm	Ø3 mm	Senkungen nach DIN 74 / BF	HSSE-Co 5 RUnaTEC	HSSE-Co 5
10.4	2.5	50.0	6.0	M 5	102 874 EP	102 874 E
12.4	2.8	56.0	8.0	M 6	102 876 EP	102 876 E
15.0	3.2	60.0	10.0	M 8	102 878 EP	102 878 E
16.5	3.2	60.0	10.0	M 8	102 879 EP	102 879 E
19.0	3.5	63.0	10.0	M 10	102 880 EP	102 880 E
20.5	3.5	63.0	10.0	M 10	102 881 EP	102 881 E
23.0	3.8	67.0	10.0	M 12	102 882 EP	102 882 E
25.0	3.8	67.0	10.0	M 12	102 883 EP	102 883 E
31.0	4.2	71.0	12.0	M 16	102 885 EP	102 885 E
40.0	5.2	80.0	12.0	-	102 894 EP	102 894 E

	HSSE-Co 5 RUnaTEC	HSSE-Co 5
<b>6</b> tfg./pcs.	Kegelsenker-Satz 4S HSSE-Co 5, ähnlich DIN 335, 90° Ø 6.3   8.3   10.4   12.4   16.5   20.5 mm	102 890 EPRO
<b>5</b> tfg./pcs.	Kegelsenker-Satz 4S HSSE-Co 5, ähnlich DIN 335, 90° Ø 6.3   10.4   16.5   20.5   25.0 mm	102 891 EPRO



102 890 EPRO



**ULTIMATECUT®**

## ULTIMATECUT Kegelsenker 4S HSS, ähnlich DIN 335, 90°



Der ULTIMATECUT Kegelsenker 4S ist ein Hochleistungswerkzeug, das für beste Performance in allen Disziplinen steht. Optimal einsetzbar sind die ULTIMATECUT Kegelsenker 4S in handgeführten Anwendungen mit dem Akku-Schrauber oder einer Bohrmaschine, in Ständerbohrmaschinen wie auch in CNC-gesteuerten Bearbeitungszentrum.



**!** 4 Schneiden aus technischen Gründen ab Ø 10,4 mm, kleinere Abmessungen in Ausführungen mit 3 Schneiden.

Verpackung: Kunststoff

Ø2 mm	Ø1 mm	L1 mm	Ø3 mm	Senkungen nach DIN 74 / BF	HSS RUnaTEC		HSS	
10.4	2.5	50.0	6.0	M 5	102 874 P	1	102 874	1
12.4	2.8	56.0	8.0	M 6	102 876 P	1	102 876	1
15.0	3.2	60.0	10.0	M 8	102 878 P	1	102 878	1
16.5	3.2	60.0	10.0	M 8	102 879 P	1	102 879	1
19.0	3.5	63.0	10.0	M 10	102 880 P	1	102 880	1
20.5	3.5	63.0	10.0	M 10	102 881 P	1	102 881	1
23.0	3.8	67.0	10.0	M 12	102 882 P	1	102 882	1
25.0	3.8	67.0	10.0	M 12	102 883 P	1	102 883	1
31.0	4.2	71.0	12.0	M 16	102 885 P	1	102 885	1
40.0	5.2	80.0	12.0	-	102 894 P	1	102 894	1

		HSS RUnaTEC	HSS
<b>6</b> tlg./pcs.	Kegelsenker-Satz 4S HSS, ähnlich DIN 335, 90° Ø 6.3   8.3   10.4   12.4   16.5   20.5 mm	102 890 PRO	102 890 RO
<b>5</b> tlg./pcs.	Kegelsenker-Satz 4S HSS, ähnlich DIN 335, 90° Ø 6.3   10.4   16.5   20.5   25.0 mm	102 891 PRO	102 891 RO



102 891 RO

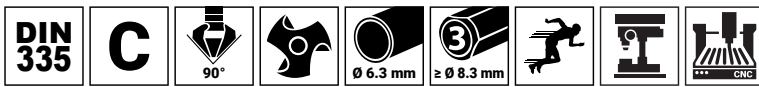

**ULTIMATECUT<sup>®</sup>**

## ULTIMATECUT Kegelsenker HSSE-Co 5, DIN 335 Form C 90°

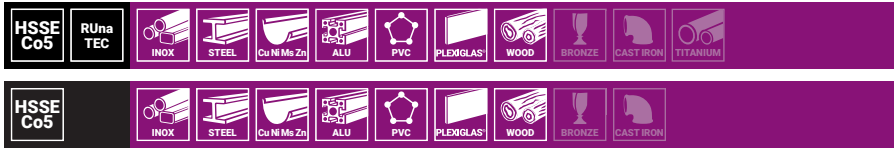

Der ULTIMATECUT Kegelsenker ist ein Hochleistungswerkzeug, das für beste Performance steht: Bis zu 30 % Zeitersparnis, doppelt so viele Senkungen wie mit Standard-Senkern und ein optimales Senkergebnis und das in fast allen Materialien.

Das erreicht der Kegelsenker von RUKO durch seine einzigartige Schneidengeometrie, mit dem speziell entwickelten variablen Hinterschliff, Übergangsradien und der extra breiten Spannt.

Optimal auch in CNC-gesteuerten Bearbeitungszentren.



**05**

Verpackung: Kunststoff

Ø2 mm	Ø1 mm	L1 mm	Ø3 mm	Senkungen nach DIN 74 / BF	HSSE-Co 5 RUnaTEC	HSSE-Co 5
6.3	1.5	45.0	5.0	M 3	102 767 EP	102 767 E
8.3	2.0	50.0	6.0	M 4	102 771 EP	102 771 E
10.4	2.5	50.0	6.0	M 5	102 774 EP	102 774 E
12.4	2.8	56.0	8.0	M 6	102 776 EP	102 776 E
15.0	3.2	60.0	10.0	M 8	102 778 EP	102 778 E
16.5	3.2	60.0	10.0	M 8	102 779 EP	102 779 E
19.0	3.5	63.0	10.0	M 10	102 780 EP	102 780 E
20.5	3.5	63.0	10.0	M 10	102 781 EP	102 781 E
23.0	3.8	67.0	10.0	M 12	102 782 EP	102 782 E
25.0	3.8	67.0	10.0	M 12	102 783 EP	102 783 E
31.0	4.2	71.0	12.0	M 16	102 785 EP	102 785 E

		HSSE-Co 5 RUnaTEC	HSSE-Co 5
<b>6</b> tfg./pcs.	Kegelsenker-Satz HSSE-Co 5 Form C 90° Ø 6.3   8.3   10.4   12.4   16.5   20.5 mm	102 790 EPRO	102 790 ERO
<b>5</b> tfg./pcs.	Kegelsenker-Satz HSSE-Co 5 Form C 90° Ø 6.3   10.4   16.5   20.5   25.0 mm	102 791 EPRO	102 791 ERO



102 790 EPRO

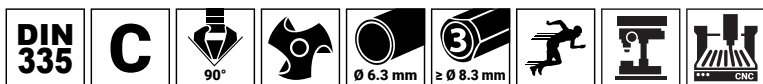

**ULTIMATECUT<sup>®</sup>**

## ULTIMATECUT Kegelsenker HSS, DIN 335 Form C 90°



Der ULTIMATECUT Kegelsenker ist ein Hochleistungswerkzeug, das für beste Performance steht: Bis zu 30 % Zeitersparnis, doppelt so viele Senkungen wie mit Standard-Senkern und ein optimales Senkergebnis und das in fast allen Materialien.

Das erreicht der Kegelsenker von RUKO durch seine einzigartige Schneidengeometrie, mit dem speziell entwickelten variablen Hinterschliff, Übergangsradien und der extra breiten Spannung.

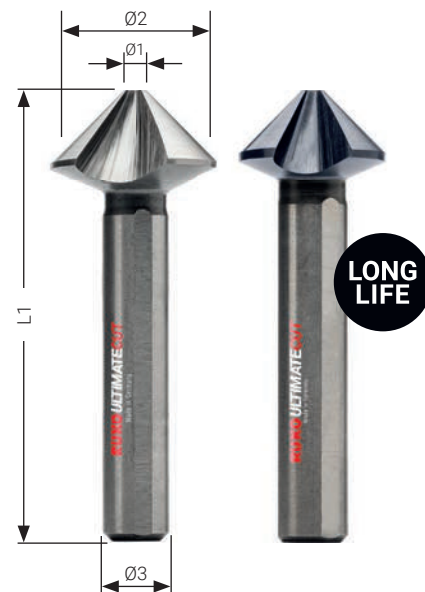

Verpackung: Kunststoff

Ø2 mm	Ø1 mm	L1 mm	Ø3 mm	Senkungen nach DIN 74 / BF	HSS RUnaTEC	HSS
6.3	1.5	45.0	5.0	M 3	102 767 P	102 767
8.3	2.0	50.0	6.0	M 4	102 771 P	102 771
10.4	2.5	50.0	6.0	M 5	102 774 P	102 774
12.4	2.8	56.0	8.0	M 6	102 776 P	102 776
15.0	3.2	60.0	10.0	M 8	102 778 P	102 778
16.5	3.2	60.0	10.0	M 8	102 779 P	102 779
19.0	3.5	63.0	10.0	M 10	102 780 P	102 780
20.5	3.5	63.0	10.0	M 10	102 781 P	102 781
23.0	3.8	67.0	10.0	M 12	102 782 P	102 782
25.0	3.8	67.0	10.0	M 12	102 783 P	102 783
31.0	4.2	71.0	12.0	M 16	102 785 P	102 785

		HSS RUnaTEC	HSS
<b>6</b> tlg./pcs.	Kegelsenker-Satz HSS Form C 90° Ø 6.3   8.3   10.4   12.4   16.5   20.5 mm	102 790 PRO	102 790 RO
<b>5</b> tlg./pcs.	Kegelsenker-Satz HSS Form C 90° Ø 6.3   10.4   16.5   20.5   25.0 mm	102 791 PRO	102 791 RO



102 791 RO



# Kegelsenker DIN 335 Form C 90°

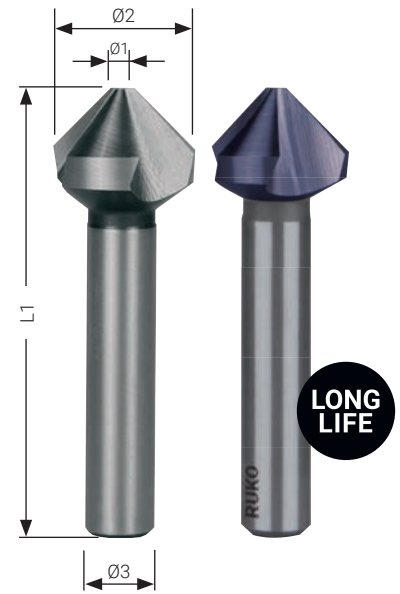
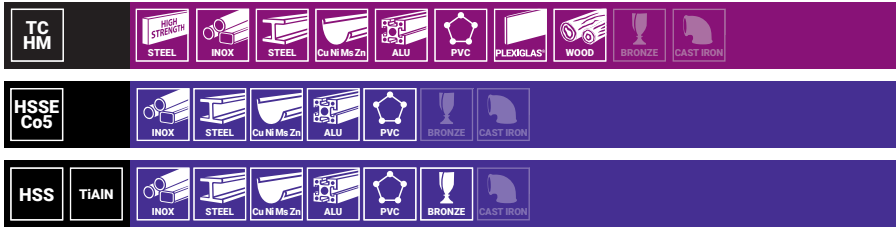

Durch die CBN tiefgeschliffenen Spannuten sind die Schneiden absolut scharf. Zum grat- und ratterfreien Ansenken, Entgraten und Versenken. Beste Ergebnisse bei niedriger Schnittgeschwindigkeit.



Verpackung: Kunststoff

Ø2 mm	Ø1 mm	L1 mm	Ø3 mm	Senkungen DIN 74		HM / TC	HSSE-Co 5	HSS TiAIN	
				AF	BF				
4.3	1.3	40.0	4.0			—	102 101 E	102 101 F	1
4.8	1.5	40.0	4.0			—	—	102 102 F	1
5.0	1.5	40.0	4.0	M 2.5		—	102 103 E	102 103 F	1
5.3	1.5	40.0	4.0			—	102 104 E	102 104 F	1
5.8	1.5	45.0	5.0			—	—	102 105 F	1
6.0	1.5	45.0	5.0	M 3		—	102 106 E	102 106 F	1
6.3	1.5	45.0	5.0		M 3	102 261	102 107 E	102 107 F	1
7.0	1.8	50.0	6.0	M 3.5		—	—	102 108 F	1
7.3	1.8	50.0	6.0			—	—	102 109 F	1
8.0	2.0	50.0	6.0	M 4		—	102 110 E	102 110 F	1
8.3	2.0	50.0	6.0		M 4	102 262	102 111 E	102 111 F	1
9.4	2.2	50.0	6.0			—	—	102 112 F	1
10.0	2.5	50.0	6.0	M 5		—	102 113 E	102 113 F	1
10.4	2.5	50.0	6.0		M 5	102 263	102 114 E	102 114 F	1
11.5	2.8	56.0	8.0	M 6		—	102 115 E	102 115 F	1
12.4	2.8	56.0	8.0		M 6	102 264	102 116 E	102 116 F	1
13.4	2.9	56.0	8.0			—	—	102 117 F	1
15.0	3.2	60.0	10.0	M 8		—	102 118 E	102 118 F	1
16.5	3.2	60.0	8.0		M 8	—	102 119 E	102 119 F	1
16.5	3.2	60.0	10.0		M 8	102 265	102 119-1 E	102 119-1 F	1
19.0	3.5	63.0	10.0	M 10		—	102 120 E	102 120 F	1
20.5	3.5	63.0	10.0		M 10	102 266	102 121 E	102 121 F	1
23.0	3.8	67.0	10.0	M 12		—	102 122 E	102 122 F	1
25.0	3.8	67.0	10.0		M 12	102 267	102 123 E	102 123 F	1
26.0	3.9	71.0	12.0	M 14		—	—	102 171 F	1
28.0	4.0	71.0	12.0		M 14	—	102 124 E	102 124 F	1
30.0	4.1	71.0	12.0	M 16		—	—	102 172 F	1
31.0	4.2	71.0	12.0		M 16	102 268	102 125 E	102 125 F	1
37.0	4.8	90.0	12.0	M 20	M 20	—	—	102 173 F	1
40.0	10.0	80.0	15.0			—	—	102 174 F	1

		HM / TC	HSSE-Co 5	HSS TiAIN
<b>5</b> Stg./pcs.	Kegelsenker-Satz DIN 335 Form C 90° Ø 6.3   10.4   16.5   20.5   25.0 mm (Ø 16.5 mm = Schaft-Ø 10.0 mm)	–	102 154 ERO	102 154 FRO
<b>6</b> Stg./pcs.	Kegelsenker-Satz DIN 335 Form C 90° Ø 6.3   8.3   10.4   12.4   16.5   20.5 mm (Ø 16.5 mm = Schaft-Ø 10.0 mm)	102 152 HMRO	102 152 ERO	102 152 FRO
<b>6</b> Stg./pcs.	Kegelsenker-Satz DIN 335 Form C 90° Ø 6.3   10.4   16.5   20.5   25.0 mm + 1 Schneidpaste 40 ml	–	102 142 E	–



102 152 HMRO



102 154 FRO



102 152 ERO



102 142 E



## Kegelsenker DIN 335 Form C 90°

<b>HSS</b>	<b>TiN</b>	STEEL	Cu Ni Mo Zn	PVC	INOX	CAST IRON	BRONZE
<b>HSS</b>		STEEL	Cu Ni Mo Zn	ALU	PVC	CAST IRON	BRONZE
<b>HSS</b>	<b>ALU</b>	ALU	Cu Ni Mo Zn	ALU	PVC		

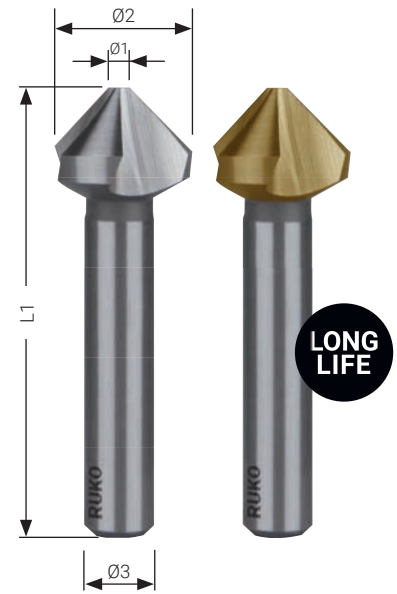

Durch die CBN tiefgeschliffenen Spannuten sind die Schneiden absolut scharf.  
Zum grat- und ratterfreien Ansenken, Entgraten und Versenken.  
Beste Ergebnisse bei niedriger Schnittgeschwindigkeit.



Verpackung: Kunststoff

Ø2 mm	Ø1 mm	L1 mm	Ø3 mm	Senkungen DIN 74		<b>HSS TiN</b>	<b>HSS</b>	<b>HSS ALU</b>	
				AF	BF				
4.3	1.3	40.0	4.0			102 101 T	102 101	—	1
4.8	1.5	40.0	4.0			102 102 T	102 102	—	1
5.0	1.5	40.0	4.0	M 2.5		102 103 T	102 103	—	1
5.3	1.5	40.0	4.0			102 104 T	102 104	—	1
5.8	1.5	45.0	5.0			102 105 T	102 105	—	1
6.0	1.5	45.0	5.0	M 3		102 106 T	102 106	—	1
6.3	1.5	45.0	5.0		M 3	102 107 T	102 107	102 107 A	1
7.0	1.8	50.0	6.0	M 3.5		102 108 T	102 108	—	1
7.3	1.8	50.0	6.0			102 109 T	102 109	—	1
8.0	2.0	50.0	6.0	M 4		102 110 T	102 110	—	1
8.3	2.0	50.0	6.0		M 4	102 111 T	102 111	102 111 A	1
9.4	2.2	50.0	6.0			102 112 T	102 112	—	1
10.0	2.5	50.0	6.0	M 5		102 113 T	102 113	—	1
10.4	2.5	50.0	6.0		M 5	102 114 T	102 114	102 114 A	1
11.5	2.8	56.0	8.0	M 6		102 115 T	102 115	—	1
12.4	2.8	56.0	8.0		M 6	102 116 T	102 116	102 116 A	1
13.4	2.9	56.0	8.0			102 117 T	102 117	—	1
15.0	3.2	60.0	10.0	M 8		102 118 T	102 118	—	1
16.5	3.2	60.0	8.0		M 8	102 119 T	102 119	102 119 A	1
16.5	3.2	60.0	10.0		M 8	102 119-1 T	102 119-1	102 119-1 A	1
19.0	3.5	63.0	10.0	M 10		102 120 T	102 120	—	1
20.5	3.5	63.0	10.0		M 10	102 121 T	102 121	102 121 A	1
23.0	3.8	67.0	10.0	M 12		102 122 T	102 122	—	1
25.0	3.8	67.0	10.0		M 12	102 123 T	102 123	102 123 A	1
26.0	3.9	71.0	12.0	M 14		102 171 T	102 171	—	1
28.0	4.0	71.0	12.0		M 14	102 124 T	102 124	—	1
30.0	4.1	71.0	12.0	M 16		102 172 T	102 172	—	1
31.0	4.2	71.0	12.0		M 16	102 125 T	102 125	102 125 A	1
37.0	4.8	90.0	12.0			102 173 T	102 173	—	1
40.0	10.0	80.0	15.0			102 174 T	102 174	—	1



		HSS TiN	HSS	HSS für ALU
<b>5</b> Stg./pcs.	Kegelsenker-Satz DIN 335 Form C 90° Ø 6.3   10.4   16.5   20.5   25.0 mm (Ø 16.5 mm = Schaft-Ø 10.0 mm)	102 154 TRO	102 154 RO	102 154 ARO
<b>6</b> Stg./pcs.	Kegelsenker-Satz DIN 335 Form C 90° Ø 6.3   8.3   10.4   12.4   16.5   20.5 mm (Ø 16.5 mm = Schaft-Ø 10.0 mm)	102 152 TRO	102 152 RO	102 152 ARO
<b>17</b> Stg./pcs.	Kegelsenker-Satz DIN 335 Form C 90° Ø 4.3   5.0   6.0   6.3   7.0   8.0   8.3   10.0   10.4   11.5   12.4   15.0   16.5   19.0   20.5   23.0   25.0 mm (Ø 16.5 mm = Schaft-Ø 10.0 mm)	–	102 155 RO	–
<b>17</b> Stg./pcs.	Kegelsenker-Satz in Holzkassette DIN 335 Form C 90° Ø 4.3   5.0   6.0   6.3   7.0   8.0   8.3   10.0   10.4   11.5   12.4   15.0   16.5   19.0   20.5   23.0   25.0 mm (Ø 16.5 mm = Schaft-Ø 10.0 mm)	–	102 155	–
<b>6</b> Stg./pcs.	Kegelsenker-Satz DIN 335 Form C 90° Ø 6.3   10.4   16.5   20.5   25.0 mm + 1 Schneidpaste 40 ml	102 142 T	102 142	102 142 A





# Kegelsenker DIN 335 Form C 90° HSS mit langem Zylinderschaft



Durch die CBN-tiefgeschliffenen Spannuten sind die Schneiden absolut scharf.  
Zum grat- und ratterfreien Ansenken, Entgraten und Versenken.  
Beste Ergebnisse bei niedriger Schnittgeschwindigkeit.

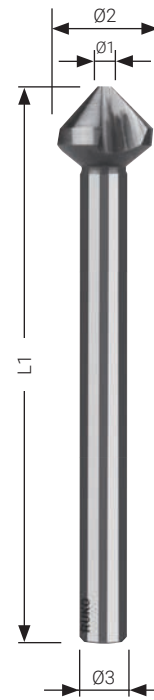

Verpackung: Kunststoff

Ø2 mm	Ø1 mm	L1 mm	Ø3 mm	Senkungen DIN 74		HSS	
				AF	BF		
6.3	1.5	85.0	5.0	-	M 3	102 271	1
8.3	2.0	85.0	6.0	-	M 4	102 272	1
10.4	2.5	88.0	6.0	-	M 5	102 273	1
12.4	2.8	108.0	8.0	-	M 6	102 274	1
15.0	3.2	110.0	10.0	M 8	-	102 275	1
16.5	3.2	112.0	10.0	-	M 8	102 276	1
20.5	3.5	115.0	10.0	-	M 10	102 277	1
25.0	3.8	118.0	10.0	-	M 12	102 278	1

		HSS
<b>6</b> Stg./pcs.	Kegel- und Entgratsenker-Satz DIN 335 Form C 90° Ø 6.3   8.3   10.4   12.4   16.5   20.5 mm	102 158 RO





## Kegelsenker DIN 335 Form D 90° HSS



Verpackung: Kunststoff

Ø2 mm	Ø1 mm	L1 mm	Ø3 mm	Senkungen DIN 74		HSS	
				AF	BF		
15.0	3.2	85.0	MK 1	M 8	-	102 126	1
16.5	3.2	85.0	MK 1	-	M 8	102 127	1
19.0	3.5	100.0	MK 2	M 10	-	102 128	1
20.5	3.5	100.0	MK 2	-	M 10	102 129	1
23.0	3.8	106.0	MK 2	M 12	-	102 130	1
25.0	3.8	106.0	MK 2	-	M 12	102 131	1
26.0	3.8	106.0	MK 2	M 14	-	102 132	1
28.0	4.0	112.0	MK 2	-	M 14	102 133	1
30.0	4.2	112.0	MK 2	M 16	-	102 134	1
31.0	4.2	112.0	MK 2	-	M 16	102 135	1
34.0	4.5	118.0	MK 2	M 18	M 18	102 136	1
37.0	4.8	118.0	MK 2	M 20	M 20	102 137	1
40.0	10.0	140.0	MK 3	-	-	102 138	1
50.0	14.0	150.0	MK 3	-	-	102 139	1
63.0	16.0	180.0	MK 4	-	-	102 140	1
80.0	22.0	190.0	MK 4	-	-	102 141	1



## Kegelsenker DIN 334 Form C 60° HSS



Verpackung: Kunststoff

Ø2 mm	Ø1 mm	L1 mm	Ø3 mm	HSS	
6.3	1.6	45.0	5.0	102 201	1
8.0	2.0	50.0	6.0	102 202	1
10.0	2.5	50.0	6.0	102 203	1
12.5	3.2	56.0	8.0	102 204	1
16.0	4.0	63.0	10.0	102 205	1
20.0	5.0	67.0	10.0	102 206	1
25.0	6.3	71.0	10.0	102 207	1



## Kegelsenker DIN 334 Form D 60° HSS



Verpackung: Kunststoff

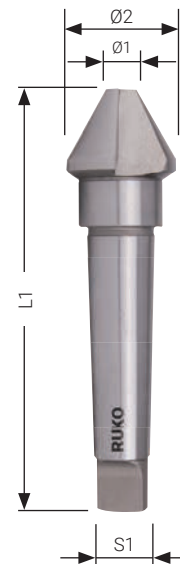

05

Ø2 mm	Ø1 mm	L1 mm	S1	HSS	
16.0	4.0	90.0	MK 1	102 208	1
20.0	5.0	106.0	MK 2	102 209	1
25.0	6.3	112.0	MK 2	102 210	1
31.5	10.0	118.0	MK 2	102 211	1
40.0	12.5	150.0	MK 3	102 212	1
50.0	16.0	160.0	MK 3	102 213	1
63.0	20.0	190.0	MK 4	102 214	1
80.0	25.0	200.0	MK 4	102 215	1



## Kegelsenker Form C 75° HSS



Verpackung: Kunststoff

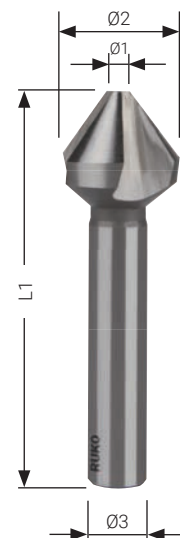

Ø2 mm	Ø1 mm	L1 mm	Ø3 mm	HSS	
6.3	1.6	45.0	5.0	102 221	1
8.3	2.0	50.0	6.0	102 222	1
10.4	2.5	50.0	6.0	102 223	1
12.4	3.2	56.0	8.0	102 224	1
16.5	4.0	63.0	10.0	102 225	1
20.5	5.0	67.0	10.0	102 226	1
25.0	6.3	71.0	10.0	102 227	1



## Kegelsenker Form D 75° HSS

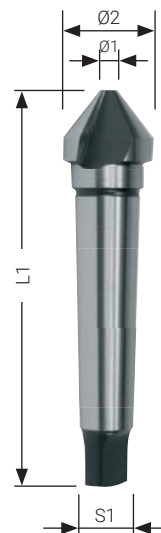

Verpackung: Kunststoff

Ø2 mm	Ø1 mm	L1 mm	S1	HSS	
16.5	3.5	87.0	MK 1	102 228	1
20.5	4.5	102.0	MK 2	102 229	1
25.0	5.0	109.0	MK 2	102 230	1
31.0	5.0	116.0	MK 2	102 231	1
40.0	10.0	145.0	MK 3	102 232	1



## Kegelsenker Form C 120° HSS

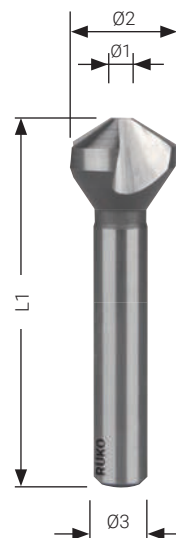

Verpackung: Kunststoff

Ø2 mm	Ø1 mm	L1 mm	Ø3 mm	HSS	
6.3	1.5	45.0	5.0	102 241	1
8.3	2.0	50.0	6.0	102 242	1
10.4	2.5	50.0	6.0	102 243	1
12.4	3.0	56.0	8.0	102 244	1
16.5	3.5	63.0	10.0	102 245	1
20.5	4.0	67.0	10.0	102 246	1
25.0	5.0	71.0	10.0	102 247	1



## Kegelsenker Form D 120° HSS

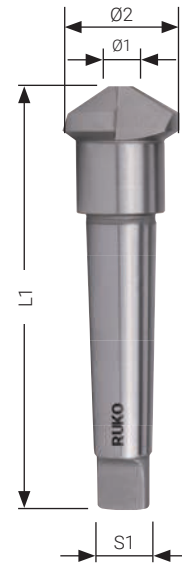

Verpackung: Kunststoff

05

Ø2 mm	Ø1 mm	L1 mm	S1	HSS	
16.5	3.5	87.0	MK 1	102 248	1
20.5	4.5	102.0	MK 2	102 249	1
25.0	5.0	109.0	MK 2	102 250	1
31.0	5.0	116.0	MK 2	102 251	1
40.0	10.0	145.0	MK 3	102 252	1



## Kegelsenker Form C 90° HSS



Nur Ansenken und Entgraten möglich.  
Senker mit einer Schneide nicht zum Vollversenken empfohlen.

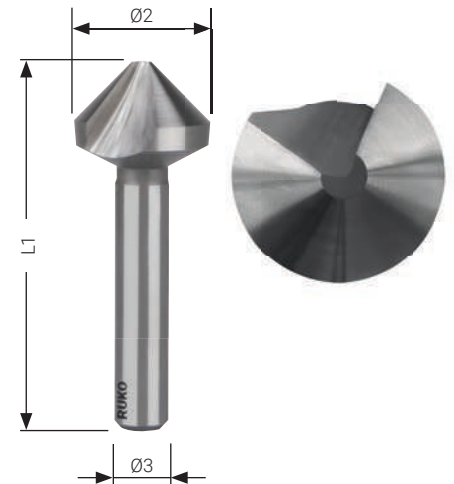

Verpackung: Kunststoff

Ø2 mm	L1 mm	Ø3 mm	HSS	
6.0	45.0	5.0	102 521	1
8.0	50.0	6.0	102 522	1
10.0	50.0	6.0	102 523	1
12.0	56.0	8.0	102 524	1
16.0	60.0	10.0	102 525	1
20.0	63.0	10.0	102 526	1
25.0	67.0	10.0	102 527	1
30.0	71.0	12.0	102 528	1
40.0	89.0	15.0	102 529	1
50.0	98.0	15.0	102 530	1



## Kegelsenker DIN 335 Form C 82° HSS – Zollabmessungen



Durch die CBN-tiefgeschliffenen Spannuten sind die Schneiden absolut scharf.  
Zum grat- und ratterfreien Ansenken, Entgraten und Versenken.  
Beste Ergebnisse bei niedriger Schnittgeschwindigkeit.

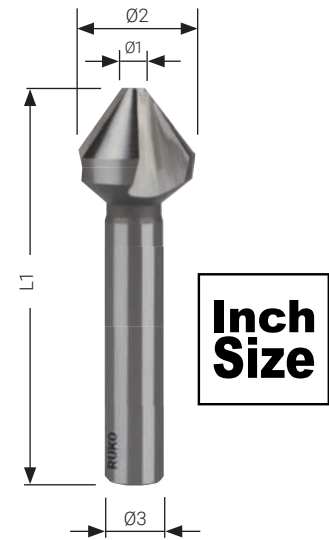

Verpackung: Kunststoff



inch	Ø2 mm	Ø1 inch	inch	Ø3 mm	inch	L1 mm	HSS	
1/4	6.4	3/64	3/16	5.0	1 3/4	45.0	102 182	1
5/16	7.9	4/64	1/4	6.0	2"	50.0	102 183	1
3/8	9.5	5/64	1/4	6.0	2"	50.0	102 184	1
1/2	12.7	6/64	5/16	8.0	2 3/16	56.0	102 186	1
5/8	15.9	7/64	3/8	10.0	2 3/8	60.0	102 188	1
3/4	19.1	8/64	3/8	10.0	2 1/2	63.0	102 189	1
7/8	22.2	9/64	3/8	10.0	2 5/8	67.0	102 190	1
1"	25.4	9/64	3/8	10.0	2 5/8	76.0	102 191	1

	HSS
<b>5</b> <small>Stk./pcs.</small> Kegelsenker-Satz Form C 82° HSS Ø 1/4   3/8   1/2   3/4   1 inch	102 193 RO





## Kegelsenker-Bit 90° HSS – kurz

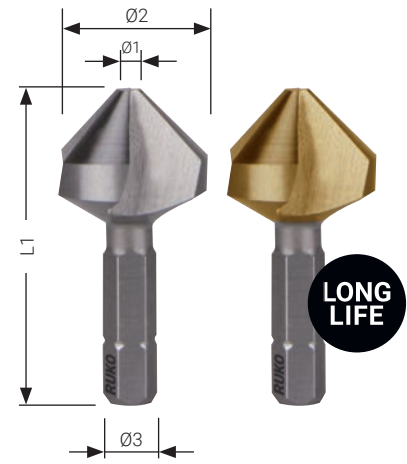
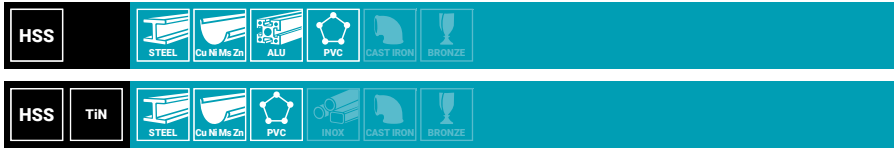

Schneller Werkzeugwechsel durch die Bitaufnahme. Ideal zum grat- und ratterfreien Ansenken, Entgraten und Versenken bei Stahl, Guß, Bunt- und Leichtmetallen. Beste Ergebnisse bei niedriger Schnittgeschwindigkeit.

05

Verpackung: Kunststoff

Ø2 mm	Ø1 mm	L1 mm	Ø3 inch	Senkungen nach DIN 74 / BF	HSS		HSS TiN	
6.3	1.5	31.0	1/4"	M 3	W102 313	1	W102 313 T	1
8.3	2.0	31.0	1/4"	M 4	W102 314	1	W102 314 T	1
10.4	2.5	34.0	1/4"	M 5	W102 315	1	W102 315 T	1
12.4	2.8	35.0	1/4"	M 6	W102 316	1	W102 316 T	1
16.5	3.2	40.0	1/4"	M 8	W102 317	1	W102 317 T	1
20.5	3.5	41.0	1/4"	M 10	W102 318	1	W102 318 T	1



## Kegelsenker-Bit 90° HSS – lang



Verpackung: Kunststoff

Ø2 mm	Ø1 mm	L1 mm	Ø3 inch	Senkungen nach DIN 74 / BF	HSS		HSS TiN	
6.3	1.5	38.0	1/4"	M 3	102 313	1	102 313T	1
8.3	2.0	38.0	1/4"	M 4	102 314	1	102 314T	1
10.4	2.5	41.0	1/4"	M 5	102 315	1	102 315T	1
12.4	2.8	42.0	1/4"	M 6	102 316	1	102 316T	1
16.5	3.2	47.0	1/4"	M 8	102 317	1	102 317T	1
20.5	3.5	48.0	1/4"	M 10	102 318	1	102 318T	1



		HSS	HSS TiN
<b>8</b> Stk./Pcs.	Kegelsenker-Bit-Satz 90° "Lang" 6 Kegel- und Entgratsenker-Bits Ø 6.3   8.3   10.4   12.4   16.5   20.5 mm + 1 Universalhandgriff 1/4" Sechskantaufnahme + 1 Schneidpaste 20 ml	102 319 RO	102 319 TRO



## Magnethalter mit 1/4" Sechskantaufnahme

Verpackung: Kunststoff

Sechskantmagnethalter	270 013	1





## Universalhandgriffe mit Senkwerkzeug



Verpackung: Kunststoff

	HSS	
Handentgrater mit Senker Ø 12.4 mm	102 143	1
Handentgrater mit Senker Ø 15.0 mm	102 144	1
Handentgrater mit Senker Ø 16.5 mm	102 145	1
Handentgrater mit Senker Ø 20.5 mm	102 146	1
Handentgrater mit Senker Ø 25.0 mm	102 147	1



102 143

## ohne Senkwerkzeug

	HSS	
Universalhandgriff für Senker mit 8.0 mm Schaft-Ø	102 148	1
Universalhandgriff für Senker mit 10.0 mm Schaft-Ø	102 149	1
Universalhandgriff für Senker mit 1/4" Sechskantschaft	102 320	1



102 148



## Querlochsensker 90°

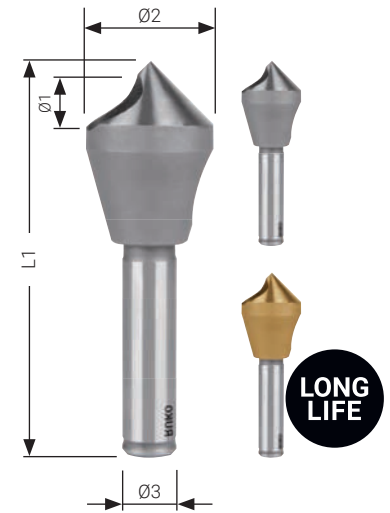

Schälender Schnitt. Der Spanablauf durch die Bohrung verhindert ein Verkleben der Späne im Werkstück. Ideal zum grat- und ratterfreien Ansenken und Entgraten bei Stahl, Guß, Bunt- und Leichtmetallen. Beste Ergebnisse bei niedriger Schnittgeschwindigkeit. Senker mit einer Schneide nicht zum Vollversenken empfohlen.

Verpackung: Kunststoff



Größe Nr.	Ø1 mm	Ø2 mm	Ø3 mm	L1 mm	HSSE-Co 5		HSS		HSS TiN	
1/4	1.0 - 4.0	6.35	6.35	45.0	102 300 E	1	—	1	—	1
2/5	2.0 - 5.0	10.00	6.00	45.0	102 301 E	1	102 301	1	102 301 T	1
5/10	5.0 - 10.0	14.00	8.00	48.0	102 302 E	1	102 302	1	102 302 T	1
10/15	10.0 - 15.0	21.00	10.00	65.0	102 303 E	1	102 303	1	102 303 T	1
15/20	15.0 - 20.0	28.00	12.00	85.0	102 304 E	1	102 304	1	102 304 T	1
20/25	20.0 - 25.0	35.00	12.00	102.0	102 305 E	1	102 305	1	102 305 T	1



102 312 RO



102 312 TRO

		HSSE-Co 5	HSS	HSS TiN
<b>4</b> tlg./pcs.	Querlochsensker-Satz 90° Nenn-Ø mm: 2/5 - 5/10 - 10/15 - 15/20	102 312 ERO	102 312 RO	102 312 TRO



## Flachsenker DIN 373 HSS mit Zylinderschaft und festem Führungszapfen

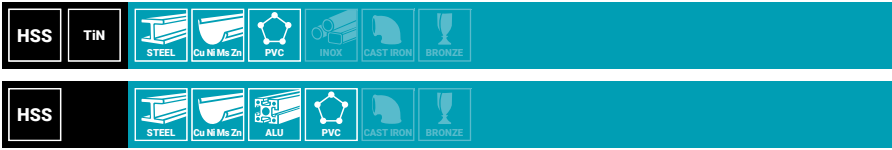

Zur Herstellung von Senkungen für Zylinderkopfschrauben, Sechskantschrauben und Muttern. Ideal zum grat- und ratterfreien Senken bei Stahl, Guß, Bunt- und Leichtmetallen. Beste Ergebnisse bei niedriger Schnittgeschwindigkeit.

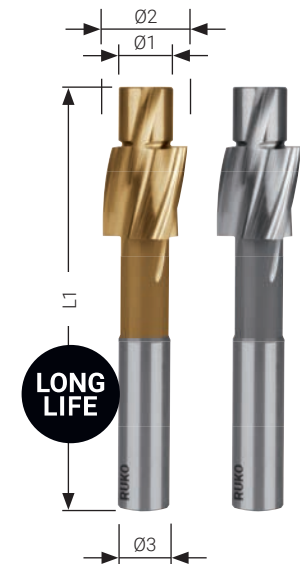

Verpackung: Kunststoff

05

### Gütegrad fein für Durchgangsloch

Für Gewinde	Ø2 mm	Ø1 mm	Ø3 mm	L1 mm	HSS TiN		HSS	
M 3	6.0	3.2	5.0	71.0	102 401 T	1	102 401	1
M 4	8.0	4.3	5.0	71.0	102 402 T	1	102 402	1
M 5	10.0	5.3	8.0	80.0	102 403 T	1	102 403	1
M 6	11.0	6.4	8.0	80.0	102 404 T	1	102 404	1
M 8	15.0	8.4	12.5	100.0	102 405 T	1	102 405	1
M 10	18.0	10.5	12.5	100.0	102 406 T	1	102 406	1
M 12	20.0	13.0	12.5	100.0	102 407 T	1	102 407	1

### Gütegrad mittel für Durchgangsloch

Für Gewinde	Ø2 mm	Ø1 mm	Ø3 mm	L1 mm	HSS TiN		HSS	
M 3	6.0	3.4	5.0	71.0	102 408 T	1	102 408	1
M 4	8.0	4.5	5.0	71.0	102 409 T	1	102 409	1
M 5	10.0	5.5	8.0	80.0	102 410 T	1	102 410	1
M 6	11.0	6.6	8.0	80.0	102 411 T	1	102 411	1
M 8	15.0	9.0	12.5	100.0	102 412 T	1	102 412	1
M 10	18.0	11.0	12.5	100.0	102 413 T	1	102 413	1
M 12	20.0	13.5	12.5	100.0	102 414 T	1	102 414	1

### Für Gewindekernloch

Für Gewinde	Ø2 mm	Ø1 mm	Ø3 mm	L1 mm	HSS TiN		HSS	
M 3	6.0	2.5	5.0	71.0	102 415 T	1	102 415	1
M 4	8.0	3.3	5.0	71.0	102 416 T	1	102 416	1
M 5	10.0	4.2	8.0	80.0	102 417 T	1	102 417	1
M 6	11.0	5.0	8.0	80.0	102 418 T	1	102 418	1
M 8	15.0	6.8	12.5	100.0	102 419 T	1	102 419	1
M 10	18.0	8.5	12.5	100.0	102 420 T	1	102 420	1
M 12	20.0	10.2	12.5	100.0	102 421 T	1	102 421	1



### Anwendungstipp

Vor allem Flachsenker sollten mit einer möglichst niedrigen Schnittgeschwindigkeit verwendet werden. Deswegen wird häufig eine geringe Drehzahl beim Einsatz von Flachsenkern empfohlen, um Rattermarken zu vermeiden.

		HSS TiN	HSS
<b>6</b> Stk./pcs.	Flachsenker-Satz mit festem Führungszapfen Gütegrad fein für Durchgangsloch M 3   M 4   M 5   M 6   M 8   M 10	102 450 TRO	102 450 RO
<b>6</b> Stk./pcs.	Flachsenker-Satz mit festem Führungszapfen Gütegrad mittel für Durchgangsloch M 3   M 4   M 5   M 6   M 8   M 10	102 451 TRO	102 451 RO
<b>6</b> Stk./pcs.	Flachsenker-Satz mit festem Führungszapfen für Gewindekernloch M 3   M 4   M 5   M 6   M 8   M 10	102 452 TRO	102 452 RO



## Senkungen nach DIN 74 Blatt 2

### Senkungen der Form H

für Zylinderschrauben nach DIN 84 und DIN 7984  
für Gewinde-Schneidschrauben nach DIN 7513, Form B  
für Gewindefurchende Schrauben DIN 7500, Form B

### Senkungen der Form J

für Zylinderschrauben nach DIN 6912

### Senkungen der Form K

für Zylinderschrauben nach DIN 912

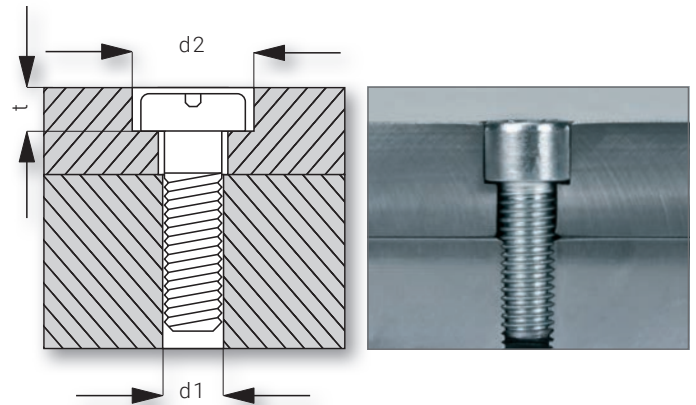

Für Gewinde	d1 fein H 12 mm	d1 mittel H 13 mm	d1 Kernloch mm	d2 H 13 mm	t Form H mm	t Form J mm	t Form K mm	Toleranz für t mm
M 3	3,2	3,4	2,5	6,0	2,4	—	3,4	0 +0,1
M 4	4,3	4,5	3,3	8,0	3,2	3,4	4,6	0 +0,4
M 5	5,3	5,5	4,2	10,0	4,0	4,2	5,7	0 +0,4
M 6	6,4	6,6	5,0	11,0	4,7	4,8	6,8	0 +0,4
M 8	8,4	9,0	6,8	15,0	6,0	6,0	6,0	0 +0,4
M 10	10,5	11,0	8,5	18,0	7,0	7,5	11,0	0 +0,4
M 12	13,0	13,5	10,2	20,0	8,0	8,5	13,0	0 +0,4
M 14	15,0	15,5	12,0	24,0	9,0	9,5	15,0	0 +0,4
M 16	17,0	17,5	14,0	26,0	10,5	11,5	17,5	0 +0,4
M 18	19,0	20,0	15,5	30,0	11,5	12,5	19,5	0 +0,4
M 20	21,0	22,0	17,5	33,0	12,5	13,5	21,5	0 +0,4
M 22	23,0	24,0	19,5	36,0	13,5	14,5	23,5	0 +0,4



## Flachsenker HSS mit Morsekegel und festem Führungszapfen



Zur Herstellung von Senkungen für Zylinderkopfschrauben, Sechskantschrauben und Muttern. Ideal zum grat- und ratterfreien Senken bei Stahl, Guß, Bunt- und Leichtmetallen. Beste Ergebnisse bei niedriger Schnittgeschwindigkeit.

Verpackung: Kunststoff

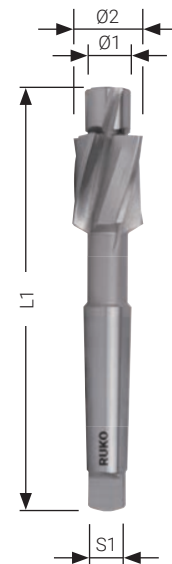

### Gütegrad fein für Durchgangsloch

Für Gewinde	Ø2 mm	Ø1 mm	S1	L1 mm	HSS	
M 10	18.0	10.5	MK 2	150.0	102 422	1
M 12	20.0	13.0	MK 2	150.0	102 423	1
M 14	24.0	15.0	MK 2	160.0	102 424	1
M 16	26.0	17.0	MK 3	190.0	102 425	1
M 18	30.0	19.0	MK 3	190.0	102 426	1
M 20	33.0	21.0	MK 3	190.0	102 427	1
M 22	36.0	23.0	MK 3	205.0	102 428	1

### Gütegrad mittel für Durchgangsloch

Für Gewinde	Ø2 mm	Ø1 mm	S1	L1 mm	HSS	
M 10	18.0	11.0	MK 2	150.0	102 429	1
M 12	20.0	13.5	MK 2	150.0	102 430	1
M 14	24.0	15.5	MK 2	160.0	102 431	1
M 16	26.0	17.5	MK 3	190.0	102 432	1
M 18	30.0	20.0	MK 3	190.0	102 433	1
M 20	33.0	22.0	MK 3	190.0	102 434	1
M 22	36.0	24.0	MK 3	205.0	102 435	1

### Für Gewindekernloch

Für Gewinde	Ø2 mm	Ø1 mm	S1	L1 mm	HSS	
M 10	18.0	8.5	MK 2	150.0	102 436	1
M 12	20.0	10.2	MK 2	150.0	102 437	1
M 14	24.0	12.0	MK 2	160.0	102 438	1
M 16	26.0	14.0	MK 3	190.0	102 439	1
M 18	30.0	15.5	MK 3	190.0	102 440	1
M 20	33.0	17.5	MK 3	190.0	102 441	1
M 22	36.0	19.5	MK 3	205.0	102 442	1

# Drehzahlrichtwerte für Kegelsenker

Material:	unlegierter Baustahl bis 700 N/mm <sup>2</sup>	unlegierter Baustahl über 700 N/mm <sup>2</sup>	legierter Stahl bis 1000 N/mm <sup>2</sup>	Gußeisen bis 250 N/mm <sup>2</sup>	Gußeisen über 250 N/mm <sup>2</sup>	CuZn-Legierung spröde	CuZn-Legierung zäh	Aluminium-Legierung bis 11% Si	Thermoplaste	Duroplaste
V <sub>c</sub> = m/min	20	15	10	10	8	40	20	20	15	10
Kühlschmierstoff	Schneid-spray	Schneid-spray	Schneid-spray	Druckluft	Druckluft	Druckluft	Druckluft	Schneid-spray	Wasser	Druckluft
Ø mm	U/min	U/min	U/min	U/min	U/min	U/min	U/min	U/min	U/min	U/min
4.3	1481	1111	741	741	593	2963	1481	1481	1111	741
5.0	1274	955	637	637	510	2548	1274	1274	955	637
5.3	1202	901	601	601	481	2404	1202	1202	901	601
5.8	1098	824	549	549	439	2196	1098	1098	824	549
6.0	1062	796	531	531	425	2123	1062	1062	796	531
6.3	1011	758	506	506	404	2022	1011	1011	758	506
7.0	910	682	455	455	364	1820	910	910	682	455
7.3	873	654	436	436	349	1745	873	873	654	436
8.0	796	597	398	398	318	1592	796	796	597	398
8.3	767	576	384	384	307	1535	767	767	576	384
9.4	678	508	339	339	271	1355	678	678	508	339
10.0	637	478	318	318	255	1274	637	637	478	318
10.4	612	459	306	306	245	1225	612	612	459	306
11.5	554	415	277	277	222	1108	554	554	415	277
12.0	531	398	265	265	212	1062	531	531	398	265
12.4	514	385	257	257	205	1027	514	514	385	257
12.5	510	382	255	255	204	1019	510	510	382	255
13.4	475	356	238	238	190	951	475	475	356	238
15.0	425	318	212	212	170	849	425	425	318	212
16.0	398	299	199	199	159	796	398	398	299	199
16.5	386	290	193	193	154	772	386	386	290	193
19.0	335	251	168	168	134	670	335	335	251	168
20.0	318	239	159	159	127	637	318	318	239	159
20.5	311	233	155	155	124	621	311	311	233	155
23.0	277	208	138	138	111	554	277	277	208	138
25.0	255	191	127	127	102	510	255	255	191	127
26.0	245	184	122	122	98	490	245	245	184	122
28.0	227	171	114	114	91	455	227	227	171	114
30.0	212	159	106	106	85	425	212	212	159	106
31.0	205	154	103	103	82	411	205	205	154	103
31.5	202	152	101	101	81	404	202	202	152	101
34.0	187	141	94	94	75	375	187	187	141	94
37.0	172	129	86	86	69	344	172	172	129	86
40.0	159	119	80	80	64	318	159	159	119	80
50.0	127	96	64	64	51	255	127	127	96	64
63.0	101	76	51	51	40	202	101	101	76	51
80.0	80	60	40	40	32	159	80	80	60	40



## Senkungen nach DIN 74 für Senkschrauben nach DIN

nach DIN 74	
Form AF	Form BF
DIN 963 / DIN 964 DIN 965 / DIN 966 DIN 7513 F. u. G. DIN 7516 D. u. E.	DIN 7991 (ISO 10642)



Form A für

- Senkschrauben nach DIN 963 und DIN 965
- Linsensenkschrauben nach DIN 964 / DIN 966
- Gewindefurchende Schrauben Form F / G DIN 7513 und Form D / E DIN 7516
- Senkholzschrauben nach DIN 97 / DIN 7997
- Linsensenkholzschrauben nach DIN 95 / DIN 7997

Form B für

- Innensechskant-Senkschrauben DIN 7991

06

























# GEWINDEBOHRWERKZEUGE

## HANDGEWINDEBOHRER

Typen- und Anwendungsübersicht	128 – 129
Handgewindebohrer M DIN 352 HSS + HSSE-Co 5	130
Schneideisen M DIN EN 22568 HSS + HSSE-Co 5	131
Handgewindebohrer M DIN 352 HSS – <i>Linksgewinde</i>	132
Schneideisen M DIN EN 22568 HSS – <i>Linksgewinde</i>	132
Handgewindebohrer MF DIN 2181 HSS	133
Schneideisen MF DIN EN 22568 HSS	134
Handgewindebohrer G DIN 5157 HSS	135
Schneideisen G DIN EN 24231 HSS	135
Handgewindebohrer BSW ≈ DIN 352 HSS	136
Schneideisen BSW ≈ DIN EN 22568 HSS	136
Handgewindebohrer UNC ≈ DIN 352 HSS	137
Schneideisen UNC ≈ DIN EN 22568 HSS	137
Handgewindebohrer UNF ≈ DIN 2181 HSS	138
Schneideisen UNF ≈ DIN EN 22568 HSS	138
Handgewindebohrer-Sätze HSS + HSSE-Co 5	139
Kombi-Handgewindebohrer- und Spiralbohrer-Sätze HSSE-Co 5	139
Kombi-Handgewindebohrer- und Spiralbohrer-Sätze HSS	140
Gewindeschneidwerkzeug-Sätze in Industriekassette HSS + HSSE-Co 5	141
Einschnittgewindebohrer M ≈ DIN 352 HSS + HSSE-Co 5	142
Einschnittgewindebohrer + ULTIMATECUT Spiralbohrer Typ FLOWSTEP®-Satz HSS	142
Einschnittgewindebohrer-Satz HSS	142
Einschnittgewindebohrer NPT HSS	143
Sechskant-Schneidmutter M DIN 382 HSS	143
Einschnittgewindebohrer G ≈ DIN 5157 HSS, geschliffen	144
Sechskant-Schneidmutter G DIN 382 HSS, geschliffen	144
Sanitär-Reparatur-Gewindeschneidwerkzeug-Satz HSS für zylindrisches Rohrgewinde	145
Gewindeschneidwerkzeug-Sätze HSS im Holzkoffer	145
Schneideisen-Halter DIN 225	146
Gewindebohrerverlängerung DIN 377	146
Verstellbare Windeisen DIN 1814	147
Kugelwindeisen	147
Werkzeughalter mit Knarre	147

# Typen- und Anwendungsübersicht

	Werkstoff	DIN	Typ	Schneidrichtung	Gewinde	Festigkeitsklassen	Nennmaß	Art.-Nr.	Seite/n
	HSS	DIN 352			M	800 N/mm²	M 2 – M 52	230 xxx	130
	HSSE Co5	DIN 352			M		M 2 – M 24	230 xxx E	
	HSS	DIN 352			M	800 N/mm²	M 3 – M 20	230 xxx Li	132
	HSS	DIN 2181			MF	800 N/mm²	MF 3 – MF 52	235 xxx	133
	HSS	DIN 5157			G (BSP)	800 N/mm²	G 1/8 – G 2"	236 xxx	135
	HSS	DIN 352			Ww (BSW)	800 N/mm²	1/16 – 2"	246 xxx	136
	HSS	DIN 352			UNC	800 N/mm²	Nr. 2 – 12 1/4 – 2"	246 xxx UNC	137
	HSS	DIN 2181			UNF	800 N/mm²	Nr. 2 – 12 1/4 – 1 1/2"	246 xxx UNF	138
	HSS	DIN 352	B		M	800 N/mm²	M 3 – M 12	231 xxx	142
	HSSE Co5	DIN 352	B		M	1000 N/mm²		231 xxx E	
	HSS		C		NPT	800 N/mm²	1/16 – 2"	231 xxx NPT	143
	HSS	DIN 5157	B		G (BSP)	800 N/mm²	G 1/8 – G 1"	236 2xx	144
	HSS	DIN 22568	B		M	800 N/mm²	M 2 – M 52	237 xxx	131
							M 3 – M 12	238 xxx	
	HSSE Co5	DIN 22568	B		M	1000 N/mm²	M 2 – M 24	237 xxx E	
	HSS	DIN 22568	B		M	800 N/mm²	M 3 – M 20	237 xxx Li	132
	HSS	DIN 22568	B		MF	800 N/mm²	MF 3 – MF 52	239 xxx	134
	HSS	DIN 24231	B		G (BSP)	800 N/mm²	G 1/8 – G 2"	240 xxx	135
	HSS	DIN 22568	B		Ww (BSW)	800 N/mm²	1/16 – 2"	247 xxx	136
	HSS	DIN 22568	B		UNC	800 N/mm²	Nr. 2 – 12 1/4 – 2"	240 xxx UNC	137
	HSS	DIN 22568	B		UNF	800 N/mm²	Nr. 2 – 12 1/4 – 1 1/2"	240 xxx UNF	138
	HSS	DIN 382			M	800 N/mm²	M 3 – M 30	267 xxx	143
	HSS	DIN 382	B		G (BSP)	800 N/mm²	G 1/8 – G 1"	267 6xx	144

Baustahl < 900 N/mm <sup>2</sup>	Inox < 1100 N/mm <sup>2</sup>	Hochfester Stahl < 1300 N/mm <sup>2</sup>	Messing	Bronze	Guss	Aluminium	Kunststoffe
●				○	○	○	○
●	●		●	○	○	●	○
●				○	○	○	○
●				○	○	○	○
●				○	○	○	○
●				○	○	○	○
●				○	○	○	○
●				○	○	○	○
●				○	○	○	○
●	●		●	○	○	●	○
●				○	○	○	○
●				○	○	○	○
●				●	●	○	○
●	●		●	●	●		○
●				●	●	○	○
●				●	●	○	○
●				●	●	○	○
●				●	●	○	○
●				●	●	○	○
●				●	●	○	○
●				●	●	○	○
●				●	●	○	○
●				●	●	○	○



# Handgewindebohrer M DIN 352

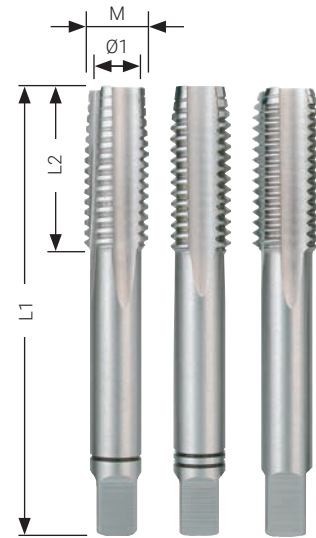
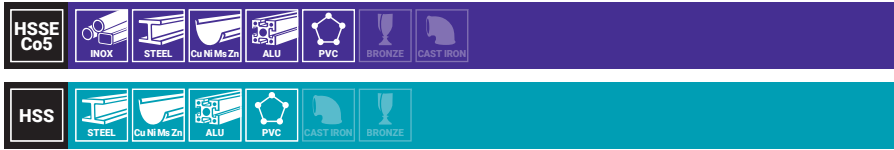

Handgewindebohrer aus Schnellarbeitsstahl (HSS).  
Für Durchgangsgewinde und Sacklochgewinde, in unlegierte und niedriglegierte Stähle, Temperguß und NE-Metalle. Das Gewinde wird in drei Arbeitsgängen geschnitten.

Auch einzeln lieferbar

Vorschneider: ca. 6 - 8 Gang Anschnitt Art.-Nr. 230 ..... **-1**  
 Mittelschneider: ca. 4 - 5 Gang Anschnitt Art.-Nr. 230 ..... **-2**  
 Fertigschneider: ca. 2 - 3 Gang Anschnitt Art.-Nr. 230 ..... **-3**

Gewinde: metrisch, DIN ISO 13  
 Flanken: hinterschiffen



Verpackung: Kunststoff  
 Satz besteht aus je 1x Vorschneider, 1x Mittelschneider und 1x Fertigschneider

Nennmaß M	Steigung mm	Kernloch Ø1 mm	L1 mm	L2 mm	HSSE-Co 5	HSS	
M 2	0.40	1.60	36.0	8.0	230 020 E	230 020	1
M 2.5	0.45	2.10	40.0	8.0	—	230 025	1
M 3	0.50	2.50	40.0	10.0	230 030 E	230 030	1
M 3.5	0.60	2.90	45.0	12.0	—	230 035	1
M 4	0.70	3.30	45.0	12.0	230 040 E	230 040	1
M 4.5	0.75	3.70	50.0	16.0	—	230 045	1
M 5	0.80	4.20	50.0	13.0	230 050 E	230 050	1
M 6	1.00	5.00	56.0	15.0	230 060 E	230 060	1
M 7	1.00	6.00	56.0	16.0	—	230 070	1
M 8	1.25	6.80	56.0	18.0	230 080 E	230 080	1
M 9	1.25	7.80	63.0	22.0	—	230 090	1
M 10	1.50	8.50	70.0	24.0	230 100 E	230 100	1
M 11	1.50	9.50	70.0	24.0	—	230 110	1
M 12	1.75	10.20	75.0	29.0	230 120 E	230 120	1
M 14	2.00	12.00	80.0	30.0	230 140 E	230 140	1
M 15	2.00	13.00	80.0	32.0	—	230 150	1
M 16	2.00	14.00	80.0	32.0	230 160 E	230 160	1
M 18	2.50	15.50	95.0	40.0	230 180 E	230 180	1
M 20	2.50	17.50	95.0	40.0	230 200 E	230 200	1
M 22	2.50	19.50	100.0	40.0	230 220 E	230 220	1
M 24	3.00	21.00	110.0	45.0	230 240 E	230 240	1
M 27	3.00	24.00	110.0	50.0	—	230 270	1
M 30	3.50	26.50	125.0	56.0	—	230 300	1
M 33	3.50	29.50	125.0	56.0	—	230 330	1
M 36	4.00	32.00	150.0	63.0	—	230 360	1
M 39	4.00	35.00	150.0	63.0	—	230 390	1
M 42	4.50	37.50	150.0	63.0	—	230 420	1
M 45	4.50	40.50	160.0	70.0	—	230 450	1
M 48	5.00	43.00	180.0	75.0	—	230 480	1
M 52	5.00	47.00	180.0	75.0	—	230 520	1



## Schneideisen M DIN EN 22568

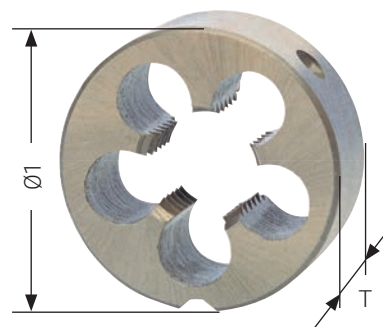
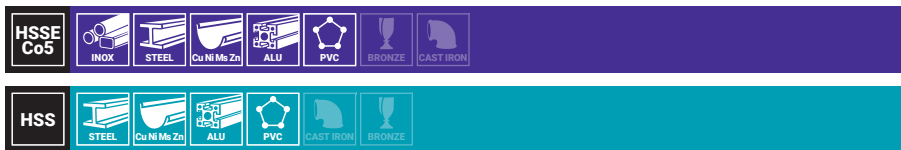

Schneideisen aus Schnellarbeitsstahl für unlegierte und niedriglegierte Stähle bis 800 N/mm<sup>2</sup> und Schneideisen aus 5 % kobaltlegiertem Schnellarbeitsstahl (HSSE-Co 5) für unlegierte und legierte Stähle bis 1.000 N/mm<sup>2</sup> Festigkeit und NE-Metalle. Das Gewinde wird in einem Arbeitsgang geschritten.

Gewinde: metrisch, DIN ISO 13

Verpackung: Kunststoff

Nennmaß M	Steigung mm	Außen Ø1 mm	Dicke T mm	HSSE-Co 5	HSS	HSS	
M 2	0.40	16.0	5.0	237 020 E	237 020	—	1
M 2.5	0.45	16.0	5.0	—	237 025	—	1
M 3	0.50	20.0	5.0	237 030 E	237 030	—	1
M 3	0.50	25.0	9.0	—	—	238 030	1
M 3.5	0.60	20.0	5.0	—	237 035	—	1
M 4	0.70	20.0	5.0	237 040 E	237 040	—	1
M 4	0.70	25.0	9.0	—	—	238 040	1
M 4.5	0.75	20.0	7.0	—	237 045	—	1
M 5	0.80	20.0	7.0	237 050 E	237 050	—	1
M 5	0.80	25.0	9.0	—	—	238 050	1
M 6	1.00	20.0	7.0	237 060 E	237 060	—	1
M 6	1.00	25.0	9.0	—	—	238 060	1
M 7	1.00	25.0	9.0	—	237 070	—	1
M 8	1.25	25.0	9.0	237 080 E	237 080	238 080	1
M 9	1.25	25.0	9.0	—	237 090	—	1
M 10	1.50	30.0	11.0	237 100 E	237 100	—	1
M 10	1.50	25.0	9.0	—	—	238 100	1
M 11	1.50	30.0	11.0	—	237 110	—	1
M 12	1.75	38.0	14.0	237 120 E	237 120	—	1
M 12	1.75	25.0	9.0	—	—	238 120	1
M 14	2.00	38.0	14.0	237 140 E	237 140	—	1
M 16	2.00	45.0	18.0	237 160 E	237 160	—	1
M 18	2.50	45.0	18.0	237 180 E	237 180	—	1
M 20	2.50	45.0	18.0	237 200 E	237 200	—	1
M 22	2.50	55.0	22.0	237 220 E	237 220	—	1
M 24	3.00	55.0	22.0	237 240 E	237 240	—	1
M 27	3.00	65.0	25.0	—	237 270	—	1
M 30	3.50	65.0	25.0	—	237 300	—	1
M 33	3.50	65.0	25.0	—	237 330	—	1
M 36	4.00	65.0	25.0	—	237 360	—	1
M 39	4.00	75.0	30.0	—	237 390	—	1
M 42	4.50	75.0	30.0	—	237 420	—	1
M 45	4.50	90.0	36.0	—	237 450	—	1
M 48	5.00	90.0	36.0	—	237 480	—	1
M 52	5.00	90.0	36.0	—	237 520	—	1





## Handgewindebohrer M DIN 352 – Linksgewinde



Auch einzeln lieferbar

Vorschneider: ca. 6 - 8 Gang Anschnitt Art.-Nr. 230 .....Li -1  
 Mittelschneider: ca. 4 - 5 Gang Anschnitt Art.-Nr. 230 .....Li -2  
 Fertigschneider: ca. 2 - 3 Gang Anschnitt Art.-Nr. 230 .....Li -3

Gewinde: metrisch, DIN ISO 13  
 Flanken: hinterschliffen

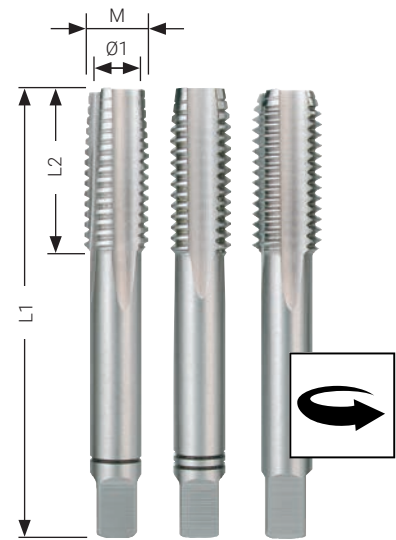

Verpackung: Kunststoff  
 Satz besteht aus je 1x Vorschneider, 1x Mittelschneider und 1x Fertigschneider

Nennmaß M	Steigung mm	Kernloch Ø1 mm	L1 mm	L2 mm	HSS	
M 3	0.50	2.50	40.0	10.0	230 030 Li	1
M 4	0.70	3.30	45.0	12.0	230 040 Li	1
M 5	0.80	4.20	50.0	13.0	230 050 Li	1
M 6	1.00	5.00	56.0	15.0	230 060 Li	1
M 8	1.25	6.80	56.0	18.0	230 080 Li	1
M 10	1.50	8.50	70.0	24.0	230 100 Li	1
M 12	1.75	10.20	75.0	29.0	230 120 Li	1
M 14	2.00	12.00	80.0	30.0	230 140 Li	1
M 16	2.00	14.00	80.0	32.0	230 160 Li	1
M 18	2.50	15.50	95.0	40.0	230 180 Li	1
M 20	2.50	17.50	95.0	40.0	230 200 Li	1

06



## Schneideisen M DIN EN 22568 – Linksgewinde



Gewinde: metrisch, DIN ISO 13

Verpackung: Kunststoff

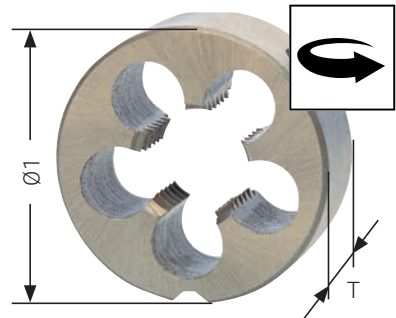

Nennmaß M	Steigung mm	Außen Ø1 mm	Dicke T mm	HSS	
M 3	0.50	20.0	5.0	237 030 Li	1
M 4	0.70	20.0	5.0	237 040 Li	1
M 5	0.80	20.0	7.0	237 050 Li	1
M 6	1.00	20.0	7.0	237 060 Li	1
M 7	1.00	25.0	9.0	237 070 Li	1
M 8	1.25	25.0	9.0	237 080 Li	1
M 10	1.50	30.0	11.0	237 100 Li	1
M 12	1.75	38.0	14.0	237 120 Li	1
M 14	2.00	38.0	14.0	237 140 Li	1
M 16	2.00	45.0	18.0	237 160 Li	1
M 18	2.50	45.0	18.0	237 180 Li	1
M 20	2.50	45.0	18.0	237 200 Li	1



# Handgewindebohrer MF DIN 2181



Auch einzeln lieferbar

Vorschneider: ca. 5 - 6 Gang Anschnitt Art.-Nr. 235 .....-1

Fertigschneider: ca. 2 - 3 Gang Anschnitt Art.-Nr. 235.....-2

Gewinde: metrisch fein DIN ISO 13

Flanken: hinterschliften

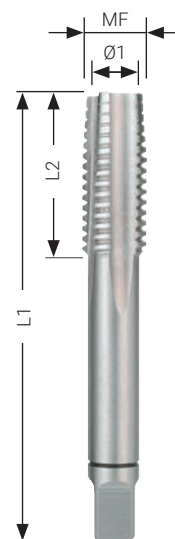

Verpackung: Kunststoff

Satz besteht aus je 1x Vorschneider und 1x Fertigschneider

Nennmaß MF	Steigung mm	Kernloch Ø1 mm	L1 mm	L2 mm	HSS	
MF 3	0.35	2.60	40.0	10.0	235 030	1
MF 4	0.35	3.10	45.0	10.0	235 040	1
MF 4	0.50	3.50	45.0	12.0	235 041	1
MF 5	0.50	4.50	50.0	13.0	235 050	1
MF 5	0.75	4.25	50.0	13.0	235 051	1
MF 6	0.50	5.50	50.0	14.0	235 061	1
MF 6	0.75	5.20	50.0	15.0	235 060	1
MF 7	0.75	6.20	50.0	14.0	235 070	1
MF 8	0.50	7.50	50.0	19.0	235 082	1
MF 8	0.75	7.20	56.0	18.0	235 080	1
MF 8	1.00	7.00	56.0	18.0	235 081	1
MF 9	0.75	8.20	56.0	19.0	235 092	1
MF 9	1.00	8.00	63.0	20.0	235 090	1
MF 10	0.75	9.20	63.0	20.0	235 102	1
MF 10	1.00	9.00	63.0	18.0	235 100	1
MF 10	1.25	8.70	70.0	24.0	235 101	1
MF 11	1.00	9.20	63.0	20.0	235 110	1
MF 11	1.25	9.80	63.0	22.0	235 111	1
MF 12	1.00	11.00	70.0	20.0	235 122	1
MF 12	1.25	10.70	70.0	20.0	235 121	1
MF 12	1.50	10.50	70.0	20.0	235 120	1
MF 13	1.00	12.00	70.0	22.0	235 130	1
MF 13	1.50	11.50	70.0	22.0	235 131	1
MF 14	1.00	13.00	70.0	20.0	235 142	1
MF 14	1.25	12.70	70.0	20.0	235 140	1
MF 14	1.50	12.50	70.0	20.0	235 141	1
MF 15	1.50	13.50	70.0	22.0	235 150	1
MF 16	1.00	15.00	70.0	20.0	235 161	1
MF 16	1.25	14.75	70.0	20.0	235 162	1
MF 16	1.50	14.50	70.0	20.0	235 160	1
MF 18	1.00	17.00	80.0	22.0	235 181	1
MF 18	1.25	16.80	80.0	22.0	235 183	1

Nennmaß MF	Steigung mm	Kernloch Ø1 mm	L1 mm	L2 mm	HSS	
MF 18	1.50	16.50	80.0	22.0	235 180	1
MF 18	2.00	16.00	80.0	22.0	235 182	1
MF 20	1.00	19.00	80.0	22.0	235 201	1
MF 20	1.25	18.80	80.0	22.0	235 203	1
MF 20	1.50	18.50	80.0	22.0	235 200	1
MF 20	2.00	18.00	80.0	22.0	235 202	1
MF 22	1.00	21.00	80.0	22.0	235 221	1
MF 22	1.50	20.50	80.0	22.0	235 220	1
MF 22	2.00	20.00	80.0	22.0	235 222	2
MF 24	1.00	23.00	90.0	22.0	235 242	1
MF 24	1.50	22.50	90.0	22.0	235 240	1
MF 24	2.00	22.00	90.0	22.0	235 241	1
MF 25	1.50	23.50	90.0	22.0	235 250	1
MF 26	1.50	24.50	90.0	22.0	235 261	1
MF 26	2.00	24.00	90.0	22.0	235 260	1
MF 27	1.50	25.50	90.0	22.0	235 270	1
MF 27	2.00	25.00	90.0	22.0	235 271	1
MF 28	1.50	26.50	90.0	22.0	235 280	1
MF 28	2.00	26.00	90.0	22.0	235 281	1
MF 30	1.00	29.00	90.0	22.0	235 300	1
MF 30	1.50	28.50	90.0	22.0	235 301	1
MF 30	2.00	28.00	90.0	22.0	235 302	1
MF 32	1.50	30.50	90.0	22.0	235 320	1
MF 35	1.50	33.50	100.0	25.0	235 350	1
MF 38	1.50	36.50	110.0	25.0	235 380	1
MF 40	1.50	38.50	110.0	25.0	235 400	1
MF 42	1.50	40.50	110.0	25.0	235 420	1
MF 45	1.50	43.50	110.0	25.0	235 450	1
MF 48	1.50	46.50	125.0	40.0	235 480	1
MF 50	1.50	48.50	125.0	40.0	235 500	1
MF 52	1.50	50.50	125.0	40.0	235 520	1



## Anwendungstipp

Nach zwei Umdrehungen die Bohrer um eine 1/3 Umdrehung zurückdrehen, um den Span zu brechen. So sinkt die Belastung auf den Gewindebohrer. Schmierung mit RUKO Schneidöl ist zu empfehlen.



## Schneideisen MF DIN EN 22568



Gewinde: metrisch fein DIN ISO 13

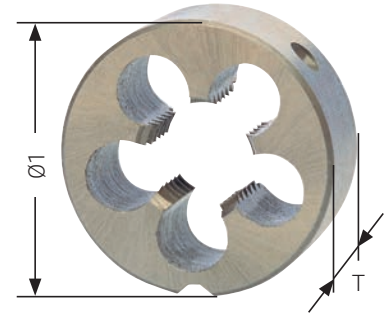

Verpackung: Kunststoff

06

Nennmaß MF	Steigung mm	Außen Ø1 mm	Dicke T mm	HSS	
MF 3	0.35	20.0	5.0	239 030	1
MF 4	0.35	20.0	5.0	239 040	1
MF 4	0.50	20.0	5.0	239 041	1
MF 5	0.50	20.0	5.0	239 050	1
MF 5	0.75	20.0	7.0	239 051	1
MF 6	0.50	20.0	5.0	239 061	1
MF 6	0.75	20.0	7.0	239 060	1
MF 7	0.75	25.0	9.0	239 070	1
MF 8	0.50	25.0	9.0	239 082	1
MF 8	0.75	25.0	9.0	239 080	1
MF 8	1.00	25.0	9.0	239 081	1
MF 9	0.75	25.0	9.0	239 090	1
MF 9	1.00	25.0	9.0	239 091	1
MF 10	0.75	30.0	11.0	239 102	1
MF 10	1.00	30.0	11.0	239 100	1
MF 10	1.25	30.0	11.0	239 101	1
MF 11	1.00	30.0	11.0	239 110	1
MF 11	1.25	30.0	11.0	239 111	1
MF 12	1.00	38.0	10.0	239 121	1
MF 12	1.25	38.0	10.0	239 122	1
MF 12	1.50	38.0	10.0	239 120	1
MF 13	1.00	38.0	10.0	239 131	1
MF 13	1.50	38.0	10.0	239 130	1
MF 14	1.00	38.0	10.0	239 142	1
MF 14	1.25	38.0	10.0	239 140	1
MF 14	1.50	38.0	10.0	239 141	1
MF 15	1.50	38.0	10.0	239 150	1
MF 16	1.00	45.0	14.0	239 161	1
MF 16	1.25	45.0	14.0	239 162	1
MF 16	1.50	45.0	14.0	239 160	1
MF 18	1.00	45.0	14.0	239 181	1
MF 18	1.25	45.0	14.0	239 183	1

Nennmaß MF	Steigung mm	Außen Ø1 mm	Dicke T mm	HSS	
MF 18	1.50	45.0	14.0	239 180	1
MF 18	2.00	45.0	14.0	239 182	1
MF 20	1.00	45.0	14.0	239 201	1
MF 20	1.25	45.0	14.0	239 203	1
MF 20	1.50	45.0	14.0	239 200	1
MF 20	2.00	45.0	14.0	239 202	1
MF 22	1.00	55.0	16.0	239 221	1
MF 22	1.50	55.0	16.0	239 220	1
MF 22	2.00	55.0	16.0	239 222	1
MF 24	1.00	55.0	16.0	239 242	1
MF 24	1.50	55.0	16.0	239 240	1
MF 24	2.00	55.0	16.0	239 241	1
MF 25	1.50	55.0	16.0	239 250	1
MF 26	1.50	55.0	16.0	239 261	1
MF 26	2.00	55.0	16.0	239 262	1
MF 27	1.50	65.0	18.0	239 270	1
MF 27	2.00	65.0	18.0	239 271	1
MF 28	1.50	65.0	18.0	239 281	1
MF 28	2.00	65.0	18.0	239 282	1
MF 30	1.00	65.0	18.0	239 300	1
MF 30	1.50	65.0	18.0	239 301	1
MF 30	2.00	65.0	18.0	239 302	1
MF 32	1.50	65.0	18.0	239 320	1
MF 35	1.50	65.0	18.0	239 350	1
MF 38	1.50	75.0	20.0	239 380	1
MF 40	1.50	75.0	20.0	239 400	1
MF 42	1.50	75.0	20.0	239 420	1
MF 45	1.50	90.0	22.0	239 450	1
MF 48	1.50	90.0	22.0	239 480	1
MF 50	1.50	90.0	22.0	239 500	1
MF 52	1.50	90.0	22.0	239 520	1



### Anwendungstipp

Es empfiehlt sich das Schneideisen zwischendurch kurz zurückzudrehen, damit die Späne brechen und die Gewindgänge nicht verstopfen. Schmierung mit RUKO Schneidöl ist zu empfehlen.



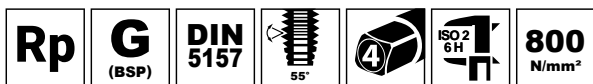

## Handgewindebohrer G DIN 5157



Auch einzeln lieferbar

Vorschneider: ca. 5 - 6 Gang Anschnitt Art.-Nr. 236 .....-1

Fertigschneider: ca. 2 - 3 Gang Anschnitt Art.-Nr. 236.....-2

Gewinde: DIN ISO 228 "G" (zyl. Rohrgewinde)

DIN 2999 "Rp" (Whitworth Rohrgewinde)

Flanken: hinterschliften

Verpackung: Kunststoff

Satz besteht aus je 1x Vorschneider und 1x Fertigschneider

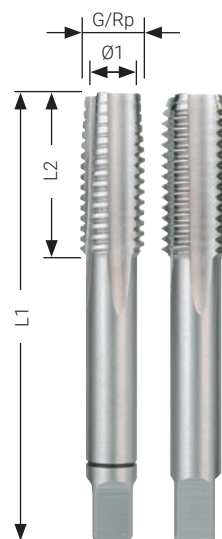

Nennmaß G	Nennmaß Rp	Gangzahl pro Zoll	Kernloch Ø1 mm	L1 mm	L2 mm	HSS	
G 1/8"	Rp 1/8"	28	8.80	63.0	18.0	236 018	1
G 1/4"	Rp 1/4"	19	11.80	70.0	20.0	236 014	1
G 3/8"	Rp 3/8"	19	15.25	70.0	20.0	236 038	1
G 1/2"	Rp 1/2"	14	19.00	80.0	22.0	236 012	1
G 5/8"	Rp 5/8"	14	21.00	80.0	22.0	236 058	1
G 3/4"	Rp 3/4"	14	24.50	90.0	22.0	236 034	1
G 7/8"	Rp 7/8"	14	28.25	90.0	22.0	236 078	1
G 1"	Rp 1"	11	30.75	100.0	25.0	236 010	1
G 1 1/8"	Rp 1 1/8"	11	35.30	125.0	40.0	236 118	1
G 1 1/4"	Rp 1 1/4"	11	39.25	125.0	40.0	236 114	1
G 1 3/8"	Rp 1 3/8"	11	41.70	140.0	40.0	236 138	1
G 1 1/2"	Rp 1 1/2"	11	45.25	140.0	40.0	236 112	1
G 1 3/4"	Rp 1 3/4"	11	51.10	140.0	40.0	236 134	1
G 2"	Rp 2"	11	57.00	160.0	40.0	236 020	1

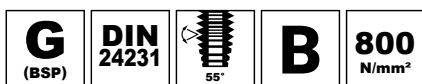

## Schneideisen G DIN EN 24231



Gewinde: DIN ISO 228 "G" (zylindrisches Rohrgewinde)

Verpackung: Kunststoff

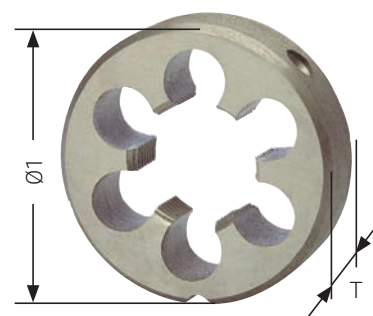

Nennmaß G	Gangzahl pro Zoll	Außen Ø1 mm	Dicke T mm	HSS	
G 1/8"	28	30.0	11.0	240 018	1
G 1/4"	19	38.0	10.0	240 014	1
G 3/8"	19	45.0	14.0	240 038	1
G 1/2"	14	45.0	14.0	240 012	1
G 5/8"	14	55.0	16.0	240 058	1
G 3/4"	14	55.0	16.0	240 034	1
G 7/8"	14	65.0	18.0	240 078	1
G 1"	11	65.0	18.0	240 010	1

Nennmaß G	Gangzahl pro Zoll	Außen Ø1 mm	Dicke T mm	HSS	
G 1 1/8"	11	75.0	20.0	240 118	1
G 1 1/4"	11	75.0	20.0	240 114	1
G 1 3/8"	11	90.0	22.0	240 138	1
G 1 1/2"	11	90.0	22.0	240 112	1
G 1 5/8"	11	90.0	22.0	240 158	1
G 1 3/4"	11	105.0	22.0	240 134	1
G 2"	11	105.0	22.0	240 020	1

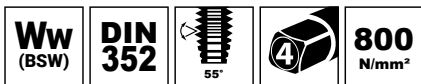

## Handgewindebohrer BSW ≈ DIN 352



Auch einzeln lieferbar

Vorschneider: ca. 5 - 6 Gang Anschnitt Art.-Nr. 246 .....-1  
 Mittelschneider: ca. 4 - 5 Gang Anschnitt Art.-Nr. 246 .....-2  
 Fertigschneider: ca. 2 - 3 Gang Anschnitt Art.-Nr. 246 .....-3

Gewinde: Whitworth BSW, früher DIN 11  
 Flanken: hinterschliften

Verpackung: Kunststoff  
 Satz besteht aus je 1x Vorschneider, 1x Mittelschneider und 1x Fertigschneider

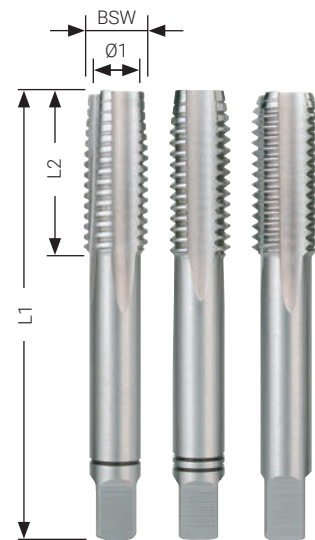

Nennmaß BSW	Gangzahl pro Zoll	Kernloch Ø1 mm	L1 mm	L2 mm	HSS	
1/16"	60	1.15	32.0	7.0	246 116	1
3/32"	48	1.80	40.0	8.0	246 332	1
1/8"	40	2.50	40.0	10.0	246 018	1
5/32"	32	3.10	45.0	12.0	246 532	1
3/16"	24	3.60	50.0	13.0	246 316	1
7/32"	24	4.40	50.0	15.0	246 732	1
1/4"	20	5.10	50.0	16.0	246 014	1
5/16"	18	6.50	56.0	18.0	246 516	1
3/8"	16	7.90	70.0	24.0	246 038	1
7/16"	14	9.30	70.0	24.0	246 716	1
1/2"	12	10.50	80.0	30.0	246 012	1
9/16"	12	12.00	80.0	30.0	246 916	1

Nennmaß BSW	Gangzahl pro Zoll	Kernloch Ø1 mm	L1 mm	L2 mm	HSS	
5/8"	11	13.50	80.0	32.0	246 058	1
3/4"	10	16.50	95.0	40.0	246 034	1
7/8"	9	19.25	100.0	40.0	246 078	1
1"	8	22.00	110.0	50.0	246 010	1
1 1/8"	7	24.75	125.0	50.0	246 118	1
1 1/4"	7	27.75	125.0	50.0	246 114	1
1 3/8"	6	30.20	150.0	63.0	246 138	1
1 1/2"	6	33.50	150.0	63.0	246 112	1
1 5/8"	5	35.50	150.0	63.0	246 158	1
1 3/4"	5	38.50	160.0	70.0	246 134	1
1 7/8"	4 1/2	41.50	180.0	75.0	246 178	1
2"	4 1/2	44.50	180.0	75.0	246 020	1

06

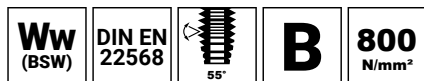

## Schneideisen BSW ≈ DIN EN 22568



Gewinde: Whitworth BSW, früher DIN 11

Verpackung: Kunststoff

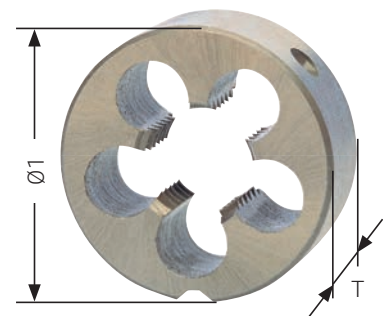

Nennmaß BSW	Gangzahl pro Zoll	Außen Ø1 mm	Dicke T mm	HSS	
1/16"	60	16.0	5.0	247 116	1
3/32"	48	16.0	5.0	247 332	1
1/8"	40	20.0	5.0	247 018	1
5/32"	32	20.0	5.0	247 532	1
3/16"	24	20.0	7.0	247 316	1
7/32"	24	20.0	7.0	247 732	1
1/4"	20	25.0	9.0	247 014	1
5/16"	18	25.0	9.0	247 516	1
3/8"	16	30.0	11.0	247 038	1
7/16"	14	30.0	11.0	247 716	1
1/2"	12	38.0	14.0	247 012	1
9/16"	12	38.0	14.0	247 916	1

Nennmaß BSW	Gangzahl pro Zoll	Außen Ø1 mm	Dicke T mm	HSS	
5/8"	11	45.0	18.0	247 058	1
3/4"	10	45.0	18.0	247 034	1
7/8"	9	55.0	22.0	247 078	1
1"	8	55.0	22.0	247 010	1
1 1/8"	7	65.0	25.0	247 118	1
1 1/4"	7	65.0	25.0	247 114	1
1 3/8"	6	65.0	25.0	247 138	1
1 1/2"	6	75.0	30.0	247 112	1
1 5/8"	5	75.0	30.0	247 158	1
1 3/4"	5	90.0	36.0	247 134	1
1 7/8"	4 1/2	90.0	36.0	247 178	1
2"	4 1/2	90.0	36.0	247 020	1



## Handgewindebohrer UNC ≈ DIN 352



Auch einzeln lieferbar

Vorschneider: ca. 5 - 6 Gang Anschnitt Art.-Nr. 246 ..... **UNC1**  
 Mittelschneider: ca. 4 - 5 Gang Anschnitt Art.-Nr. 246 ..... **UNC2**  
 Fertigschneider: ca. 2 - 3 Gang Anschnitt Art.-Nr. 246 ..... **UNC3**

Gewinde: amerikanisches Grobgewinde UNC  
 Flanken: hinterschliften

Verpackung: Kunststoff  
 Satz besteht aus je 1x Vorschneider, 1x Mittelschneider und 1x Fertigschneider

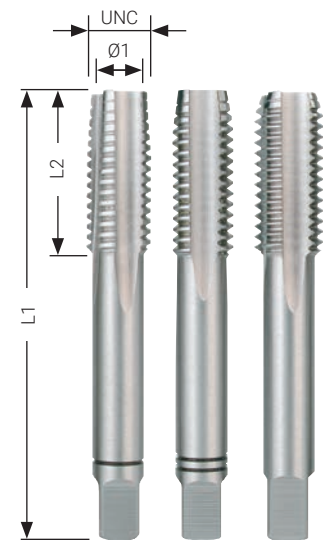

Nennmaß UNC	Gangzahl pro Zoll	Kernloch Ø1 mm	L1 mm	L2 mm	HSS	
Nr. 2	56	1.8	36.0	11.0	246 020 UNC	1
Nr. 3	48	2.1	36.0	11.0	246 030 UNC	1
Nr. 4	40	2.3	40.0	12.0	246 040 UNC	1
Nr. 5	40	2.6	40.0	12.0	246 050 UNC	1
Nr. 6	32	2.8	45.0	14.0	246 060 UNC	1
Nr. 8	32	3.5	45.0	14.0	246 080 UNC	1
Nr. 10	24	3.9	50.0	16.0	246 100 UNC	1
Nr. 12	24	4.5	50.0	18.0	246 120 UNC	1
1/4"	20	5.1	50.0	19.0	246 014 UNC	1
5/16"	18	6.6	56.0	22.0	246 516 UNC	1
3/8"	16	8.0	70.0	24.0	246 038 UNC	1
7/16"	14	9.4	70.0	24.0	246 716 UNC	1

Nennmaß UNC	Gangzahl pro Zoll	Kernloch Ø1 mm	L1 mm	L2 mm	HSS	
1/2"	13	10.8	75.0	29.0	246 012 UNC	1
9/16"	12	12.2	80.0	30.0	246 916 UNC	1
5/8"	11	13.5	80.0	32.0	246 058 UNC	1
3/4"	10	16.5	95.0	40.0	246 034 UNC	1
7/8"	9	19.5	100.0	40.0	246 078 UNC	1
1"	8	22.2	110.0	50.0	246 010 UNC	1
1 1/8"	7	25.0	132.0	56.0	246 118 UNC	1
1 1/4"	7	28.0	132.0	56.0	246 114 UNC	1
1 3/8"	6	30.7	150.0	63.0	246 138 UNC	1
1 1/2"	6	34.0	150.0	63.0	246 112 UNC	1
1 3/4"	5	39.5	160.0	70.0	246 134 UNC	1
2"	4 1/2	45.0	190.0	80.0	246 200 UNC	1



## Schneideisen UNC ≈ DIN EN 22568



Gewinde: amerikanisches Grobgewinde UNC

Verpackung: Kunststoff

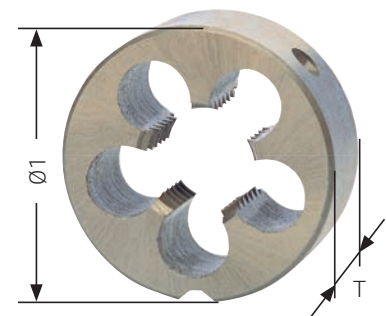

Nennmaß UNC	Gangzahl pro Zoll	Außen Ø1 mm	Dicke T mm	HSS	
Nr. 2	56	16.0	5.0	240 020 UNC	1
Nr. 3	48	16.0	5.0	240 030 UNC	1
Nr. 4	40	20.0	5.0	240 040 UNC	1
Nr. 5	40	20.0	5.0	240 050 UNC	1
Nr. 6	32	20.0	7.0	240 060 UNC	1
Nr. 8	32	20.0	7.0	240 080 UNC	1
Nr. 10	24	20.0	7.0	240 100 UNC	1
Nr. 12	24	20.0	7.0	240 120 UNC	1
1/4"	20	20.0	7.0	240 014 UNC	1
5/16"	18	25.0	9.0	240 516 UNC	1
3/8"	16	30.0	11.0	240 038 UNC	1
7/16"	14	30.0	11.0	240 716 UNC	1

Nennmaß UNC	Gangzahl pro Zoll	Außen Ø1 mm	Dicke T mm	HSS	
1/2"	13	38.0	14.0	240 012 UNC	1
9/16"	12	38.0	14.0	240 916 UNC	1
5/8"	11	45.0	18.0	240 058 UNC	1
3/4"	10	45.0	18.0	240 034 UNC	1
7/8"	9	55.0	22.0	240 078 UNC	1
1"	8	55.0	22.0	240 010 UNC	1
1 1/8"	7	65.0	25.0	240 118 UNC	1
1 1/4"	7	65.0	25.0	240 114 UNC	1
1 3/8"	6	65.0	25.0	240 138 UNC	1
1 1/2"	6	75.0	30.0	240 112 UNC	1
1 3/4"	5	90.0	36.0	240 134 UNC	1
2"	4.5	90.0	36.0	240 200 UNC	1



## Handgewindebohrer UNF ≈ DIN 2181



Auch einzeln lieferbar

Vorschneider: ca. 5 - 6 Gang Anschnitt Art.-Nr. 246 ..... **UNF1**  
 Fertigschneider: ca. 2 - 3 Gang Anschnitt Art.-Nr. 246 ..... **UNF3**

Gewinde: amerikanisches Feingewinde UNF  
 Flanken: hinterschliffen

Verpackung: Kunststoff  
 Satz besteht aus je 1x Vorschneider und 1x Fertigschneider

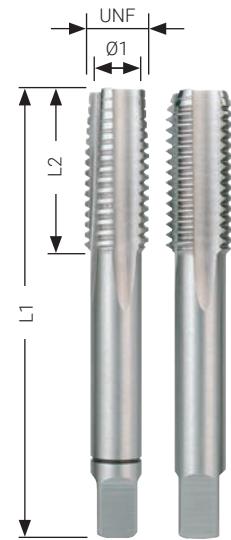

06

Nennmaß UNF	Gangzahl pro Zoll	Kernloch Ø1 mm	L1 mm	L2 mm	HSS	
Nr. 2	64	1.85	32.0	10.0	246 020 UNF	1
Nr. 3	56	2.15	32.0	10.0	246 030 UNF	1
Nr. 4	48	2.40	36.0	11.0	246 040 UNF	1
Nr. 5	44	2.70	36.0	11.0	246 050 UNF	1
Nr. 6	40	2.95	40.0	12.0	246 060 UNF	1
Nr. 8	36	3.50	40.0	12.0	246 080 UNF	1
Nr. 10	32	4.10	45.0	14.0	246 100 UNF	1
Nr. 12	28	4.60	50.0	14.0	246 120 UNF	1
1/4"	28	5.50	50.0	18.0	246 014 UNF	1
5/16"	24	6.90	56.0	22.0	246 516 UNF	1
3/8"	24	8.50	63.0	22.0	246 038 UNF	1

Nennmaß UNF	Gangzahl pro Zoll	Kernloch Ø1 mm	L1 mm	L2 mm	HSS	
7/16"	20	9.90	63.0	22.0	246 716 UNF	1
1/2"	20	11.50	75.0	24.0	246 012 UNF	1
9/16"	18	12.90	80.0	28.0	246 916 UNF	1
5/8"	18	14.50	80.0	28.0	246 058 UNF	1
3/4"	16	17.50	95.0	32.0	246 034 UNF	1
7/8"	14	20.50	100.0	36.0	246 078 UNF	1
1"	12	23.25	110.0	40.0	246 010 UNF	1
1 1/8"	12	22.00	110.0	50.0	246 118 UNF	1
1 1/4"	12	22.00	132.0	56.0	246 114 UNF	1
1 3/8"	12	28.00	132.0	56.0	246 138 UNF	1
1 1/2"	12	32.00	150.0	63.0	246 112 UNF	1



## Schneideisen UNF ≈ DIN EN 22568



Gewinde: amerikanisches Feingewinde UNF

Verpackung: Kunststoff

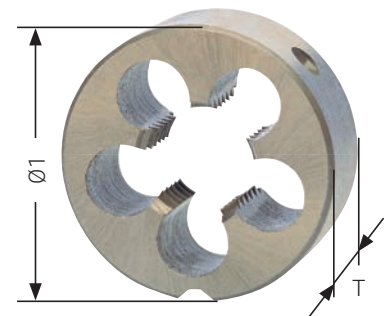

Nennmaß UNF	Gangzahl pro Zoll	Außen Ø1 mm	Dicke T mm	HSS	
Nr. 2	64	16.0	5.0	240 020 UNF	1
Nr. 3	56	16.0	5.0	240 030 UNF	1
Nr. 4	48	16.0	5.0	240 040 UNF	1
Nr. 5	44	20.0	5.0	240 050 UNF	1
Nr. 6	40	20.0	5.0	240 060 UNF	1
Nr. 8	36	20.0	7.0	240 080 UNF	1
Nr. 10	32	20.0	7.0	240 100 UNF	1
Nr. 12	28	20.0	7.0	240 120 UNF	1
1/4"	28	20.0	7.0	240 014 UNF	1
5/16"	24	25.0	9.0	240 516 UNF	1
3/8"	24	30.0	11.0	240 038 UNF	1

Nennmaß UNF	Gangzahl pro Zoll	Außen Ø1 mm	Dicke T mm	HSS	
7/16"	20	30.0	11.0	240 716 UNF	1
1/2"	20	38.0	10.0	240 012 UNF	1
9/16"	18	38.0	10.0	240 916 UNF	1
5/8"	18	45.0	14.0	240 058 UNF	1
3/4"	16	45.0	14.0	240 034 UNF	1
7/8"	14	55.0	16.0	240 078 UNF	1
1"	12	55.0	16.0	240 010 UNF	1
1 1/8"	12	65.0	18.0	240 118 UNF	1
1 1/4"	12	65.0	18.0	240 114 UNF	1
1 3/8"	12	65.0	18.0	240 138 UNF	1
1 1/2"	12	75.0	20.0	240 112 UNF	1



## Handgewindebohrer-Sätze HSS + HSSE-Co 5



245 001 RO

		HSSE-Co 5	HSS
<b>21</b> tlg./pcs.	Handgewindebohrer Satz M DIN 352 je ein 3-teiliger Satz M 3   M 4   M 5   M 6   M 8   M 10   M 12 in Kunststoffkassette	245 001 ERO	245 001 RO
<b>22</b> tlg./pcs.	Handgewindebohrer Satz M DIN 352 je ein 3-teiliger Satz M 3   M 4   M 5   M 6   M 8   M 10   M 12 1 Windeisen DIN 1814 Gr. 1 1/2 in Industriekassette	245 002 E	245 002



## Kombi-Handgewindebohrer- und Spiralbohrer-Sätze HSSE-Co 5



		HSSE-Co 5
<b>29</b> tlg./pcs.	Kombi Handgewindebohrer und Spiralbohrer Satz in Industriekassette  Handgewindebohrer M DIN 352 je ein 3-teiliger Satz M 3   M 4   M 5   M 6   M 8   M 10   M 12 7 Spiralbohrer DIN 338 Typ VA - Ø 2.5   3.3   4.2   5.0   6.8   8.5   10.2 mm 1 Windeisen DIN 1814 Gr. 1 1/2	245 003 E
<b>28</b> tlg./pcs.	Kombi Handgewindebohrer und Spiralbohrer Satz in Kunststoffkassette  Handgewindebohrer M DIN 352 je ein 3-teiliger Satz M 3   M 4   M 5   M 6   M 8   M 10   M 12 7 Spiralbohrer DIN 338 Typ VA - Ø 2.5   3.3   4.2   5.0   6.8   8.5   10.2 mm	245 003 ERO
<b>44</b> tlg./pcs.	Kombi Handgewindebohrer und Spiralbohrer Satz im Werkzeugmagazin  Handgewindebohrer M DIN 352 je ein 3-teiliger Satz M 3   M 4   M 5   M 6   M 8   M 10   M 12 7 Spiralbohrer DIN 338 Typ VA - Ø 2.5   3.3   4.2   5.0   6.8   8.5   10.2 mm 7 Schneideisen M DIN EN 22568 - M 3   M 4   M 5   M 6   M 8   M 10   M 12 5 Schneideisenhalter DIN 225 - 20.0 x 5.0   20.0 x 7.0   25.0 x 9.0   30.0 x 11.0   38.0 x 14.0 mm 2 Windeisen DIN 1814 Gr. 1 und Gr. 2 1 Schraubendreher 1 Gewindeschablone	245 030 E



## Kombi-Handgewindebohrer- und Spiralbohrer-Sätze HSS



		HSS
<b>29</b> tfg./pcs.	<p>Kombi Handgewindebohrer und Spiralbohrer Satz in Industriekassette</p> <p>Handgewindebohrer M DIN 352 je ein 3-teiliger Satz M 3   M 4   M 5   M 6   M 8   M 10   M 12 7 Spiralbohrer DIN 338 Typ N - Ø 2.5   3.3   4.2   5.0   6.8   8.5   10.2 mm 1 Windeisen DIN 1814 Gr. 1 1/2</p>	245 003
<b>28</b> tfg./pcs.	<p>Kombi Handgewindebohrer und Spiralbohrer Satz in Kunststoffkassette</p> <p>Handgewindebohrer M DIN 352 je ein 3-teiliger Satz M 3   M 4   M 5   M 6   M 8   M 10   M 12 7 Spiralbohrer DIN 338 Typ N - Ø 2.5   3.3   4.2   5.0   6.8   8.5   10.2 mm</p>	245 003 RO
<b>44</b> tfg./pcs.	<p>Kombi Handgewindebohrer und Spiralbohrer Satz in Industriekassette</p> <p>Handgewindebohrer M DIN 352 je ein 3-teiliger Satz M 3   M 4   M 5   M 6   M 8   M 10   M 12 7 Spiralbohrer DIN 338 Typ N - Ø 2.5   3.3   4.2   5.0   6.8   8.5   10.2 mm 7 Schneideisen M DIN EN 22568 - M 3   M 4   M 5   M 6   M 8   M 10   M 12 5 Schneideisenhalter DIN 225 - 20.0 x 5.0   20.0 x 7.0   25.0 x 9.0   30.0 x 11.0   38.0 x 14.0 mm 2 Windeisen DIN 1814 Gr. 1 und Gr. 2 1 Schraubendreher 1 Gewindeschablone</p>	245 030



245 003



245 003 RO



245 030



## Gewindeschneidwerkzeug-Sätze



		HSSE-Co 5	HSS
<b>31</b> tlg./pcs.	Gewindeschneidwerkzeug Hobbysatz je ein 3-teiliger Satz Handgewindebohrer M DIN 352 M 3   M 4   M 5   M 6   M 8   M 10   M 12 + 7 Schneideisen Ø 25.0 mm ≈ DIN EN 22568 M 3   M 4   M 5   M 6   M 8   M 10   M 12 + 1 Schneideisenhalter DIN 225 25.0 x 9.0 mm + 1 Windeisen DIN 1814 Gr. 1½ + 1 Schraubendreher	245 010 E	245 010
<b>37</b> tlg./pcs.	Gewindeschneidwerkzeug-Satz je ein 3-teiliger Satz Handgewindebohrer M DIN 352 M 3   M 4   M 5   M 6   M 8   M 10   M 12 + 7 Schneideisen M DIN EN 22568 M 3   M 4   M 5   M 6   M 8   M 10   M 12 + 5 Schneideisenhalter DIN 225 20.0 x 5.0   20.0 x 7.0   25.0 x 9.0   30.0 x 11.0   38.0 x 14.0 mm + 2 Windeisen DIN 1814 Gr. 1 und Gr. 2 + 1 Schraubendreher + 1 Gewindeschablone	245 020 E	245 020
<b>54</b> tlg./pcs.	Gewindeschneidwerkzeug-Satz je ein 3-teiliger Satz Handgewindebohrer M DIN 352 M 3   M 4   M 5   M 6   M 8   M 10   M 12   M 14   M 16   M 18   M 20 + 11 Schneideisen M DIN EN 22568 M 3   M 4   M 5   M 6   M 8   M 10   M 12   M 14   M 16   M 18   M 20 + 6 Schneideisenhalter DIN 225 20.0 x 5.0   20.0 x 7.0   25.0 x 9.0   30.0 x 11.0   38.0 x 14.0   45.0 x 18.0 mm + 2 Windeisen DIN 1814 Gr. 1 und Gr. 3 + 1 Schraubendreher + 1 Gewindeschablone	245 040 E	245 040
<b>43</b> tlg./pcs.	Gewindeschneidwerkzeug-Satz MF (metrisch fein) je ein 2-teiliger Satz Handgewindebohrer MF DIN 2181 MF 3   MF 4   MF 5   MF 6   MF 8   MF 10   MF 12   MF 14   MF 16   MF 18   MF 20 + 11 Schneideisen MF DIN 22568 MF 3   MF 4   MF 5   MF 6   MF 8   MF 10   MF 12   MF 14   MF 16   MF 18   MF 20 + 6 Schneideisenhalter DIN 225 20.0 x 5.0   20.0 x 7.0   25.0 x 9.0   30.0 x 11.0   38.0 x 10.0   45.0 x 14.0 mm + 2 Windeisen DIN 1814 Gr. 1 und Gr. 3 + 1 Schraubendreher + 1 Gewindeschablone	—	245 041



245 010 E



245 020



245 040

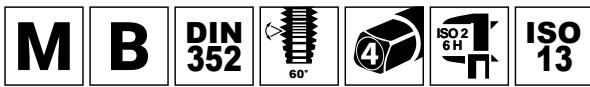

## Einschnittgewindebohrer M ≈ DIN 352

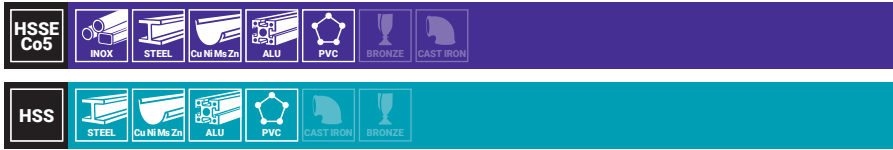

Gewindebohrer HSS für Durchgangsgewinde, in unlegierte und niedriglegierte Stähle bis 800 N/mm<sup>2</sup> und Gewindebohrer HSSE-Co 5 für Durchgangsgewinde, in unlegierte und legierte Stähle bis 1000 N/mm<sup>2</sup> Festigkeit, Temperguß und NE-Metalle. Das Gewinde kann von Hand und im Maschinengebrauch in einem Arbeitsgang geschnitten werden.

Gewinde: metrisch fein DIN ISO 13  
Flanken: hinterschliften

Verpackung: Kunststoff  
Satz besteht aus je 1x Vorschneider, 1x Mittelschneider und 1x Fertigschneider

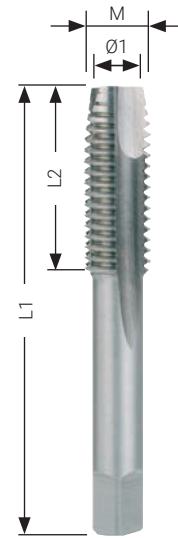

06

Nennmaß M	Steigung mm	Kernloch Ø1 mm	L1 mm	L2 mm	HSSE-Co 5	HSS	
M 3	0.50	2.50	40.0	10.0	231 030 E	231 030	1
M 4	0.70	3.30	45.0	12.0	231 040 E	231 040	1
M 5	0.80	4.20	50.0	13.0	231 050 E	231 050	1
M 6	1.00	5.00	50.0	15.0	231 060 E	231 060	1
M 8	1.25	6.80	56.0	18.0	231 080 E	231 080	1
M 9	1.25	7.80	67.0	22.0	—	231 090	1
M 10	1.50	8.50	70.0	24.0	231 100 E	231 100	1
M 12	1.75	10.20	75.0	29.0	231 120 E	231 120	1

## Einschnittgewindebohrer + ULTIMATECUT Spiralbohrer Typ FLOWSTEP®-Satz



		HSS
<b>15</b> tfg./pcs.	Einschnittgewindebohrer-Satz M ≈ DIN 352 HSS 7 Einschnittgewindebohrer M 3   M 4   M 5   M 6   M 8   M 10   M 12 + 7 ULTIMATECUT Spiralbohrer DIN 338 Typ FLOWSTEP® HSS Ø 2.5   3.3   4.2   5.0   6.8   8.5   10.2 mm + 1 Windeisen DIN 1814 Gr. 1 1/2	259 004 RO



## Einschnittgewindebohrer + Spiralbohrer-Satz DIN 338 Typ N

		HSS
<b>15</b> tfg./pcs.	Einschnittgewindebohrer-Satz M ≈ DIN 352 HSS 7 Einschnittgewindebohrer M 3   M 4   M 5   M 6   M 8   M 10   M 12 + 7 Spiralbohrer DIN 338 Typ N HSS Ø 2.5   3.3   4.2   5.0   6.8   8.5   10.2 mm + 1 Windeisen DIN 1814 Gr. 1 1/2	245 004 RO





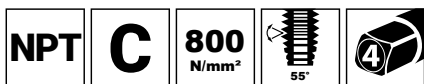

## Einschnittgewindebohrer NPT HSS



Für Durchgangsgewinde, in unlegierte und niedriglegierte Stähle bis 800 N/mm<sup>2</sup> Festigkeit, Temperguß und NE-Metalle. Das Gewinde kann von Hand und im Maschinengebrauch in einem Arbeitsgang geschnitten werden.

**Hinweis: Zylindrisch vorbohren!**

Gewinde: amerikanisches kegeliges Rohrgewinde nach ANSI B.1.20.1

Flanken: hinterschliffen

Kegel: 1:16

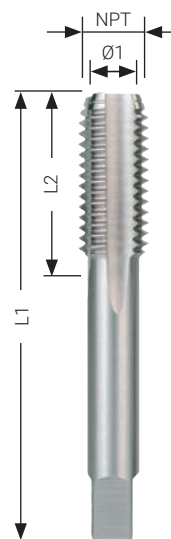

Verpackung: Kunststoff

Nennmaß NPT	Gangzahl pro Zoll	Kernloch Ø1 mm	Schnitttiefe in mm	L1 mm	L2 mm	HSS	
1/16"	27.0	6.00	12.00	65.0	19.0	231 116 NPT	1
1/8"	27.0	8.25	12.00	65.0	19.0	231 018 NPT	1
1/4"	18.0	10.70	17.50	70.0	25.0	231 014 NPT	1
3/8"	18.0	14.10	17.50	75.0	26.0	231 038 NPT	1
1/2"	14.0	17.40	22.90	80.0	31.0	231 012 NPT	1
3/4"	14.0	22.60	23.00	100.0	33.0	231 034 NPT	1
1"	11.5	28.50	27.40	110.0	38.0	231 010 NPT	1
1 1/4"	11.5	37.00	28.10	125.0	41.0	231 114 NPT	1
1 1/2"	11.5	43.50	28.40	140.0	42.0	231 112 NPT	1
2"	11.5	55.00	28.40	160.0	44.0	231 020 NPT	1

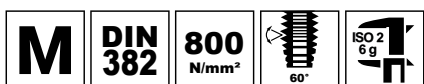

## Sechskant-Schneidmuttern M DIN 382 HSS



Gewinde: metrisch DIN ISO 13

Verpackung: Kunststoff

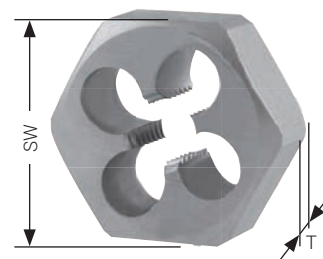

Nennmaß M	Steigung mm	Schlüssel- weite SW mm	Dicke T mm	HSS	
M 3	0.50	18.0	5.0	267 030	1
M 4	0.70	18.0	5.0	267 040	1
M 5	0.80	18.0	7.0	267 050	1
M 6	1.00	18.0	7.0	267 060	1
M 8	1.25	21.0	9.0	267 080	1
M 10	1.50	27.0	11.0	267 100	1
M 12	1.75	36.0	14.0	267 120	1
M 14	2.00	36.0	14.0	267 140	1

Nennmaß M	Steigung mm	Schlüssel- weite SW mm	Dicke T mm	HSS	
M 16	2.00	41.0	18.0	267 160	1
M 18	2.50	41.0	18.0	267 180	1
M 20	2.50	41.0	18.0	267 200	1
M 22	2.50	50.0	22.0	267 220	1
M 24	3.00	50.0	22.0	267 240	1
M 27	3.00	60.0	25.0	267 270	1
M 30	3.50	60.0	25.0	267 300	1



## Einschnittgewindebohrer G ≈ DIN 5157 HSS, geschliffen



Gewinde: DIN ISO 228 "G" (zylindrisches Rohrgewinde)  
 DIN 2999 "Rp" (Whitworth Rohrgewinde)  
 Flanken: hinterschliffen

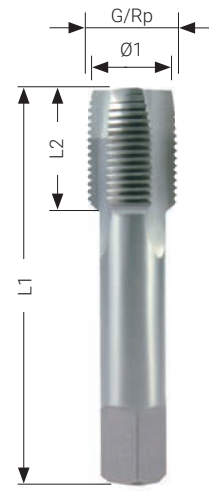

Verpackung: Kunststoff

Nennmaß G	Nennmaß Rp	Gangzahl pro Zoll	Kernloch Ø1 mm	L1 mm	L2 mm	HSS	
G 1/8"	Rp 1/8"	28	8.6	63.0	20.0	236 218	1
G 1/4"	Rp 1/4"	19	11.5	70.0	22.0	236 214	1
G 3/8"	Rp 3/8"	19	15.0	70.0	22.0	236 238	1
G 1/2"	Rp 1/2"	14	19.0	80.0	22.0	236 212	1
G 3/4"	Rp 3/4"	14	24.5	90.0	22.0	236 234	1
G 1"	Rp 1"	11	30.5	100.0	25.0	236 210	1

06



## Sechskant-Schneidmutter G DIN 382 HSS, geschliffen



Gewinde: DIN ISO 228 "G" (zylindrisches Rohrgewinde)

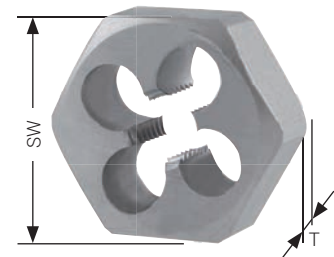

Verpackung: Kunststoff

Nennmaß G	Gangzahl pro Zoll	Schlüsselweite SW mm	Dicke T mm	HSS	
G 1/8"	28	27.0	11.0	267 618	1
G 1/4"	19	36.0	10.0	267 614	1
G 3/8"	19	41.0	14.0	267 638	1
G 1/2"	14	41.0	14.0	267 612	1
G 3/4"	14	50.0	16.0	267 634	1
G 1"	11	60.0	18.0	267 610	1



## Sanitär-Reparatur-Gewindeschneidwerkzeug-Satz HSS für zylindrisches Rohrgewinde



		HSS
<b>13</b> tfg./pcs.	<p>Sanitär-Reparatur-Gewindeschneidwerkzeug-Satz 6 Einschnittgewindebohrer G/Rp ≈ DIN 5157 HSS geschliffen G/Rp 1/8" x 28   G/Rp 1/4" x 19   G/Rp 3/8" x 19   G/Rp 1/2" x 14   G/Rp 3/4" x 14   G/Rp 1" x 11</p> <p>+ 6 Sechskant-Schneidmutter G DIN 382 HSS geschliffen G 1/8" x 28   G 1/4" x 19   G 3/8" x 19   G 1/2" x 14   G 3/4" x 14   G 1" x 11</p> <p>+ 1 Schneidpaste 40 ml</p>	245 059

## Gewindeschneidwerkzeug-Sätze HSS im Holzkoffer



245 004 RO

		HSS
<b>28</b> tfg./pcs.	<p>Gewindeschneidwerkzeug-Satz je ein 2-teiliger Satz Handgewindebohrer G DIN 5157 1/8"   1/4"   3/8"   1/2"   5/8"   3/4"   1"</p> <p>+ 7 Schneideisen G DIN EN 24231 1/8"   1/4"   3/8"   1/2"   5/8"   3/4"   1"</p> <p>+ 5 Schneideisenhalter DIN 225 30.0 x 11.0   38.0 x 10.0   45.0 x 14.0   55.0 x 16.0   65.0 x 18.0 mm</p> <p>+ 2 Windeisen DIN 1814 Gr. 3 und Gr. 5</p>	245 074
<b>35</b> tfg./pcs.	<p>Gewindeschneidwerkzeug-Satz je ein 2-teiliger Satz Handgewindebohrer UNF ≈ DIN 2181 1/4"   5/16"   3/8"   7/16"   1/2"   5/8"   3/4"   7/8"   1"</p> <p>+ 9 Schneideisen UNF ≈ DIN EN 22568 1/4"   5/16"   3/8"   7/16"   1/2"   5/8"   3/4"   7/8"   1"</p> <p>+ 6 Schneideisenhalter DIN 225 20.0 x 7.0   25.0 x 9.0   30.0 x 11.0   38.0 x 10.0   45.0 x 14.0   55.0 x 16.0 mm</p> <p>+ 2 Windeisen DIN 1814 Gr. 2 und Gr. 4</p>	245 073
<b>44</b> tfg./pcs.	<p>Gewindeschneidwerkzeug-Satz je ein 3-teiliger Satz Handgewindebohrer UNC ≈ DIN 352 1/4"   5/16"   3/8"   7/16"   1/2"   5/8"   3/4"   7/8"   1"</p> <p>+ 9 Schneideisen UNC ≈ DIN EN 22568 1/4"   5/16"   3/8"   7/16"   1/2"   5/8"   3/4"   7/8"   1"</p> <p>+ 6 Schneideisenhalter DIN 225 20.0 x 7.0   25.0 x 9.0   30.0 x 11.0   38.0 x 10.0   45.0 x 18.0   55.0 x 22.0 mm</p> <p>+ 2 Windeisen DIN 1814 Gr. 2 und Gr. 4</p>	245 072

## Schneideisen-Halter DIN 225

Zur Aufnahme geschlossener und geschlitzter Schneideisen nach DIN EN 24231.  
Mit Stahlgriffen, davon ein Griff abschraubbar und 5 Schrauben zur Befestigung des Schneideisens.

Ausführung: Gehäuse aus Zinkdruckguss

Verpackung: Kunststoff

Größe	Dicke mm	L1 mm	für Schneideisen			HSS	
			M + MF	Ww	G		
16	5.0	160.0	M 1 - M 2.6	1/16 - 3/32	—	242 165	1
20	5.0	175.0	M 3 - M 4	1/8 - 5/32	—	242 205	1
20	7.0	175.0	M 4.5 - M 6	3/16 - 1/4	—	242 207	1
25	9.0	210.0	M 7 - M 9	5/16	1/16	242 259	1
30	11.0	260.0	M 10 - M 11	3/8 - 7/16	1/8	242 3011	1
38	14.0	310.0	M 12 - M 14	1/2 - 9/16	—	242 3814	1
45	18.0	440.0	M 16 - M 20	5/8 - 3/4	—	242 4518	1
55	22.0	495.0	M 22 - M 24	7/8 - 1	—	242 5522	1
65	25.0	630.0	M 27 - M 36	1 1/8 - 1 3/8	—	242 6525	1
75	30.0	700.0	M 38 - M 42	1 1/2 - 1 5/8	—	242 7530	1
90	36.0	900.0	M 45 - M 52	1 3/4 - 2	—	242 9036	1
105	36.0	930.0	M 54 - M 63	2 1/4 - 2 3/4	—	242 10536	1

38	10.0	310.0	MF 12 - MF 14	—	1/4	242 3810	1
45	14.0	440.0	MF 16 - MF 20	—	3/8 - 1/2	242 4514	1
55	16.0	495.0	MF 22 - MF 24	—	5/8 - 3/4	242 5516	1
65	18.0	630.0	MF 27 - MF 36	—	7/8 - 1	242 6518	1
75	20.0	750.0	MF 38 - MF 42	—	1 1/8 - 1 1/4	242 7520	1
90	22.0	900.0	MF 45 - MF 52	—	1 3/8 - 1 5/8	242 9022	1
105	22.0	930.0	MF 54 - MF 63	—	1 3/4 - 2	242 10522	1

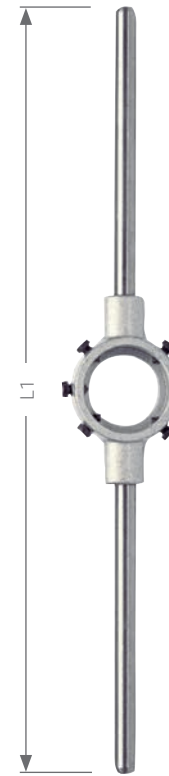

## Gewindebohrerverlängerung DIN 377

Zur Verlängerung von Handgewindebohrern.  
Gleich großer Innen- und Außenvierkant.

Ausführung: gehärtet und geschliffen  
Schaft: Vierkant nach DIN 10

Verpackung: Kunststoff

Vierkant mm	Länge mm	für Handgewindebohrer			HSS	
		M	Ww	G		
2.1	60.0	M 1 - M 2.6	1/16 - 3/32	—	241 021	1
2.7	80.0	M 3	—	—	241 027	1
3.4	95.0	M 4	5/32	—	241 034	1
4.9	110.0	M 5 - M 8	7/32 - 5/16	—	241 049	1
5.5	115.0	M 9 - M 10	3/8	1/8	241 055	1
7.0	125.0	M 12	1/2	—	241 070	1
9.0	135.0	M 13 - M 16	9/16 - 5/8	1/4	241 090	1
11.0	150.0	M 18	11/16 - 3/4	—	241 110	1
12.0	155.0	M 20	13/16	1/2	241 120	1
14.5	174.0	M 22 - M 24	7/8 - 15/16	5/8	241 145	1
16.0	185.0	M 27 - M 28	1	3/4	241 160	1
18.0	195.0	M 30 - M 32	1 1/8	7/8	241 180	1

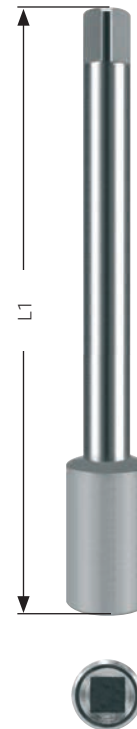

## Verstellbare Windeisen DIN 1814

Ideal zum Gewindeschneiden an schwer zugänglichen Stellen.  
Mit Zweiback-Spannfutter zum Spannen von Vierkantschäften.  
Mit Stahlgriffen, davon ein Griff abschraubbar.

Ausführung: Gehäuse aus Zinkdruckguss  
Spannbacken: gehärtet

Verpackung: Kunststoff

Größe	L1 mm	für Handgewindebohrer			G		
		M	Ww				
0	125.0	M 1 - M 8	1/16 - 5/16	—	241 100	1	
1	175.0	M 1 - M 10	1/8 - 3/8	—	241 101	1	
1 1/2	175.0	M 1 - M 12	1/8 - 1/2	1/8	241 112	1	
2	265.0	M 4 - M 12	3/16 - 5/8	1/8 - 3/8	241 102	1	
3	370.0	M 5 - M 20	1/4 - 3/4	1/8 - 1/2	241 103	1	
4	480.0	M 11 - M 27	1/2 - 1	1/8 - 3/4	241 104	1	
5	700.0	M 13 - M 32	5/8 - 1 1/4	1/4 - 1	241 105	1	
6	1000.0	M 18 - M 42	3/4 - 1 1/2	1/4 - 1 1/4	241 106	1	
7	1250.0	M 25 - M 52	7/8 - 2	5/8 - 2 1/4	241 107	1	

## Kugelwindeisen

Ideal zur schnellen Aufnahme von Gewindebohrern.

Ausführung: Gehäuse aus Zinkdruckguss  
Schaft: Vierkant nach DIN 10

Verpackung: Kunststoff

Größe	L1 mm	für Handgewindebohrer			G		
		M	Ww				
0	200.0	M 1 - M 4	1/16 - 5/32	—	241 200	1	
1	200.0	M 3.5 - M 8	5/32 - 5/16	—	241 201	1	
2	240.0	M 4 - M 10	5/32 - 3/8	—	241 202	1	
3	300.0	M 5 - M 12	7/32 - 1/2	—	241 203	1	
4	340.0	M 9 - M 16	3/8 - 5/8	—	241 204	1	
5	450.0	M 12 - M 20	1/2 - 13/16	—	241 205	1	
6	650.0	M 18 - M 27	11/16 - 1	—	241 206	1	

## Werkzeughalter mit Knarre

Ideal zum Gewindeschneiden an schwer zugänglichen Stellen.  
Mit Zweiback-Spannfutter zum Spannen von Vierkantschäften.

Ausführung: einstellbar links, rechts, fest  
Schaft: verschiebbarer Quergriff mit Rillen an beiden Enden  
Oberfläche: verchromt

Verpackung: Kunststoff

Größe	L1 mm	für Handgewindebohrer			G		
		M	Ww				
1	85.0	M 3 - M 10	1/8 - 3/8	—	241 001	1	
2	100.0	M 5 - M 12	7/32 - 1/2	1/8	241 002	1	
10	250.0	M 3 - M 10	1/8 - 3/8	—	241 010	1	
20	300.0	M 5 - M 12	7/32 - 1/2	1/8	241 020	1	

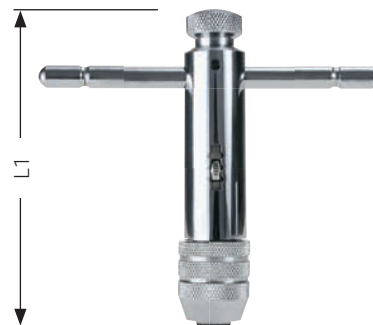
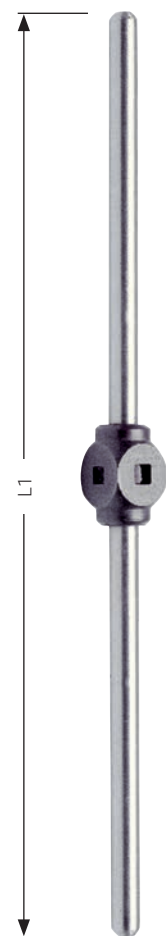
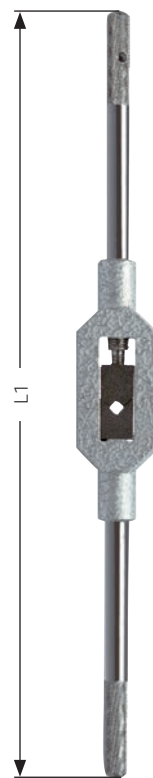

06



































# GEWINDEBOHRWERKZEUGE

## MASCHINENGWINDEBOHRER

Typen- und Anwendungsübersicht	150 – 153
Produktbeschreibung für Maschinengewindebohrer	154 – 155
ULTIMATECUT Kombi-Maschinengewindebohrer-Bit für Kernloch- und Durchgangsgewinde HSS + RUnATEC	158
Maschinengewindebohrer, metrisch, DIN 371 mit verstärktem Schaft für Durchgangsgewinde HSS + HSS TiN + HSSE-Co 5 + HSSE-Co 5 VAP + HSSE-Co 5 TiAlN	160
Maschinengewindebohrer, metrisch, DIN 371 mit verstärktem Schaft und Spiralnut 35° für Sacklochgewinde HSS + HSS TiN + HSSE-Co 5 + HSSE-Co 5 VAP + HSSE-Co 5 TiAlN	161
Maschinengewindebohrer, metrisch, DIN 376 mit Überlaufschaft für Durchgangsgewinde HSS + HSS TiN + HSSE-Co 5 + HSSE-Co 5 VAP + HSSE-Co 5 TiAlN	162
Maschinengewindebohrer, metrisch, DIN 376 mit Überlaufschaft und Spiralnut 35° für Sacklochgewinde HSS + HSS TiN + HSSE-Co 5 + HSSE-Co 5 VAP + HSSE-Co 5 TiAlN	163
Maschinengewindebohrer-Sätze, metrisch DIN 371/376 HSS + HSS TiN + HSSE-Co 5 + HSSE-Co 5 VAP + HSSE-Co 5 TiAlN	164
Maschinengewindebohrer- und Spiralbohrer-Satz, metrisch, HSS + HSSE-Co 5	164 – 165
Maschinengewindebohrer- und ULTIMATECUT Spiralbohrer Typ FLOWSTEP®-Satz HSS + HSSE-Co 5	166
Maschinengewindebohrer, metrisch, DIN 371 mit verstärktem Schaft für Durchgangsgewinde und ausgesetzten Zähnen HSS	167
Maschinengewindebohrer, metrisch, DIN 376 mit Überlaufschaft für Durchgangsgewinde, mit ausgesetzten Zähnen HSS	167
Maschinengewindebohrer, metrisch, DIN 371 mit verstärktem Schaft für Durchgangsgewinde HSSE-Co 5 TiCN	168
Maschinengewindebohrer, metrisch, Überlaufschaft für Durchgangsgewinde HSSE-Co 5 TiCN	168
Maschinengewindebohrer, metrisch fein, DIN 376 mit Überlaufschaft für Durchgangsgewinde HSSE-Co 5 TiCN	169
Maschinengewindebohrer, metrisch fein, DIN 374 mit Überlaufschaft und Rechtsspiralnuten 35° für Sacklochgewinde HSSE-Co 5	170
Maschinengewindebohrer UNC mit verstärktem Schaft für Durchgangsgewinde HSSE-Co 5	171
Maschinengewindebohrer UNC mit Überlaufschaft für Durchgangsgewinde HSSE-Co 5	171
Maschinengewindebohrer UNC mit verstärktem Schaft und Spiralnut 35° für Sacklochgewinde, HSSE-Co 5	172
Maschinengewindebohrer UNC mit Überlaufschaft und Spiralnut 35° für Sacklochgewinde, HSSE-Co 5	172
Maschinengewindebohrer UNF mit verstärktem Schaft für Durchgangsgewinde HSSE-Co 5	173
Maschinengewindebohrer UNF mit Überlaufschaft für Durchgangsgewinde HSSE-Co 5	173
Maschinengewindebohrer UNF mit verstärktem Schaft und Spiralnut 35° für Sacklochgewinde, HSSE-Co 5	174
Maschinengewindebohrer UNF mit Überlaufschaft und Spiralnut 35° für Sacklochgewinde, HSSE-Co 5	174
Maschinengewindebohrer PG DIN 40430 mit Überlaufschaft, für Durchgangsgewinde, HSS	175
Muttergewindebohrer, metrisch, DIN 357 zur Aufnahme mehrerer geschnittener Muttern HSS – lang	175
Gewindeformer DIN 2174 mit verstärktem Schaft für Durchgangsgewinde und Sacklochgewinde HSSE-Co 5 TiAlN	176
Kombi-Maschinengewindebohrer-Bit für Kernloch- und Durchgangsgewinde HSS + TiN – lang	177
Sechskantmagnethalter	177
Kombi-Maschinengewindebohrer-Bit für Kernloch- und Durchgangsgewinde HSS + TiN – kurz	178
Zubehört + Gewindeausdreh-Satz	179

# Typen- und Anwendungsübersicht

	Werkstoff	Oberfläche	DIN	Typ	Gewinde	Festigkeitsklassen	Sacklochbohrung / Durchgangslochbohrung	Nennmaß	Art.-Nr.	Seite/n
	HSS				M			M 3 – M 10	270 0xx	158
	HSS	RUNa TEC			M				270 0xx P	
	HSS	Blank	DIN 371	B	M	800 N/mm <sup>2</sup>		M 2 – M 10	232 xxx	160
	HSSE Co5	Blank	DIN 371	B	M	1000 N/mm <sup>2</sup>			232 xxx E	
	HSSE Co5	VAP	DIN 371	B	M	1000 N/mm <sup>2</sup>			232 xxx VA	
	HSS	TiN	DIN 371	B	M	900 N/mm <sup>2</sup>			232 xxx T	
	HSSE Co5	TiAlN	DIN 371	B	M	1200 N/mm <sup>2</sup>			232 xxx EF	
	HSS	TiN	DIN 371	B	M	900 N/mm <sup>2</sup>			232 xxx T	
	HSS	Blank	DIN 371	C	M	800 N/mm <sup>2</sup>		M 2 – M 10	234 xxx	161
	HSSE Co5	Blank	DIN 371	C	M	1000 N/mm <sup>2</sup>			234 xxx E	
	HSSE Co5	VAP	DIN 371	C	M	1000 N/mm <sup>2</sup>			234 xxx VA	
	HSS	TiN	DIN 371	C	M	900 N/mm <sup>2</sup>			234 xxx T	
	HSSE Co5	TiAlN	DIN 371	C	M	1200 N/mm <sup>2</sup>			234 xxx EF	
	HSS	Blank	DIN 376	B	M	800 N/mm <sup>2</sup>		M 12 – M 30	232 xxx	162
	HSSE Co5	Blank	DIN 376	B	M	1000 N/mm <sup>2</sup>		M 3 – M 30	232 xxx E	
	HSSE Co5	VAP	DIN 376	B	M	1000 N/mm <sup>2</sup>		M 3 – M 30	232 xxx VA	
	HSS	TiN	DIN 376	B	M	900 N/mm <sup>2</sup>		M 12 – M 30	232 xxx T	
	HSSE Co5	TiAlN	DIN 376	B	M	1200 N/mm <sup>2</sup>		M 3 – M 30	232 xxx EF	
	HSS	Blank	DIN 376	C	M	800 N/mm <sup>2</sup>		M 12 – M 30	233 xxx	163
	HSSE Co5	Blank	DIN 376	C	M	1000 N/mm <sup>2</sup>		M 3 – M 30	233 xxx E	
	HSSE Co5	VAP	DIN 376	C	M	1000 N/mm <sup>2</sup>		M 3 – M 30	233 xxx VA	
	HSS	TiN	DIN 376	C	M	900 N/mm <sup>2</sup>		M 12 – M 30	233 xxx T	
	HSSE Co5	TiAlN	DIN 376	C	M	1200 N/mm <sup>2</sup>		M 3 – M 30	233 xxx EF	
 	HSS	Blank	DIN 371	B AZ	M	800 N/mm <sup>2</sup>		M 3 – M 10	272 xxx	167
	HSS	Blank	DIN 376	B AZ	M	800 N/mm <sup>2</sup>		M 12 – M 24	272 xxx	





































Baustahl < 900 N/mm <sup>2</sup>	Inox < 1100 N/mm <sup>2</sup>	Hochfester Stahl < 1300 N/mm <sup>2</sup>	Messing	Bronze	Guss	Aluminium	Kunststoffe
●			●	○	○	●	○
●			●	●	○	●	○
●			●	○	○	●	○
●			●	○	○	●	○
●	●		●	○	○	●	○
●	○		●	○	○		○
●	●	●	●	●	●	●	○
●			●	○	○	●	○
●	●		●	○	○	●	○
●	●		●	○	○	●	○
●	○		●	○	○		○
●	●	●	●	●	●	●	○
●			●	○	○	●	○
●			●	○	○	●	○
●	●		●	○	○	●	○
●	○		●	○	○		○
●	●	●	●	●	●	●	○
●			●	○	○	●	○
●	●		●	○	○	●	○
●	○		●	○	○		○
●	●	●	●	●	●	●	○
○				●		●	○
○				●		●	○

● Hauptanwendung

○ Nebenanwendung

# Typen- und Anwendungsübersicht

	Werkstoff	Oberfläche	DIN	Typ	Gewinde	Festigkeitsklassen	Sacklochbohrung / Durchgangslochbohrung	Nennmaß	Art.-Nr.	Seite/n
	HSSE Co5	TiCN	DIN 371	C	M	800 N/mm²		M 3 – M 10	273 xxx ETC	168
	HSSE Co5	TiCN	DIN 376	C	M	1000 N/mm²		M 12 – M 24	273 xxx ETC	
	HSSE Co5	Blank	DIN 5156	B	MF	1000 N/mm²		MF 4 – 30	260 xxx E	169
	HSSE Co5	Blank	DIN 374	C	MF	1000 N/mm²		MF 4 – MF 30	261 xxx E	170
	HSSE Co5	Blank		B	UNC	1000 N/mm²		Nr. 4 – 12 1/4 – 3/8"	265 xxx UNC	171
	HSSE Co5	Blank		B	UNC	1000 N/mm²		7/16 – 1"	265 xxx UNC	
	HSSE Co5	Blank		C	UNC	1000 N/mm²		Nr. 4 – 12 1/4 – 3/8"	266 xxx UNC	172
	HSSE Co5	Blank		C	UNC	1000 N/mm²		7/16 – 1"	266 xxx UNC	
	HSSE Co5	Blank		B	UNF	1000 N/mm²		Nr. 4 – 12 1/4 – 3/8"	265 xxx UNF	173
	HSSE Co5	Blank		B	UNF	1000 N/mm²		7/16 – 1"	265 xxx UNF	
	HSSE Co5	Blank		C	UNF	1200 N/mm²		Nr. 4 – 12 1/4 – 3/8"	266 xxx UNF	174
	HSSE Co5	Blank		C	UNF	1000 N/mm²		7/16 – 1"	266 xxx UNF	
	HSS	Blank	DIN 40430	B	PG	800 N/mm²		PG 7 – 48	264 xxx	175
	HSS	Blank	DIN 357		M	800 N/mm²		M 3 – M 24	243 xxx	
	HSSE Co5	TiAlN	DIN 2174	D	M	1200 N/mm²		M 3 – M 12	271 0xx F	176
	HSS	Blank			M	600 N/mm²		M 3 – M 10	270 0xx	177
	HSS	TiN			M	900 N/mm²			270 0xx T	
	HSS	Blank			M	600 N/mm²		M 3 – M 10	R 270 0xx	178
	HSS	TiN			M	900 N/mm²			R 270 0xx T	



# Produktbeschreibung für Maschinengewindebohrer



Maschinengewindebohrer aus Schnellarbeitsstahl. Für Durchgangsgewinde und Sacklochgewinde, in unlegierte Stähle bis 800 N/mm<sup>2</sup> Festigkeit. Das Gewinde wird in einem Arbeitsgang geschnitten.

Schnellarbeitsstahl, vor allem bekannt als High Speed Steel (HSS), bezeichnet eine Gruppe legierter Werkzeugstähle mit bis zu 2,06 % Kohlenstoffgehalt und bis zu 30 % Anteil an Legierungselementen wie Wolfram, Molybdän, Vanadium, Kobalt, Nickel und Titan. HSS-Werkstoffe zeichnen sich durch große Härte, Verschleißfestigkeit und eine Warmfestigkeit bis 600 °C aus. Die HSS-Werkzeuge sind unempfindlicher gegen Stöße und Schwingungen, die bei den härteren Schneidwerkstoffen teils rasch zu Brüchen führen können.



06



Maschinengewindebohrer aus kobaltlegiertem Schnellarbeitsstahl. Durch die höhere Warmhärtebeständigkeit wird eine höhere Standzeit erreicht. Für Durchgangsgewinde und Sacklochgewinde, in unlegierte und legierte Stähle bis 1.000 N/mm<sup>2</sup> Festigkeit und NE-Metalle. Das Gewinde wird in einem Arbeitsgang geschnitten.

Wie Schnellarbeitsstahl mit einer Kobaltlegierung von 5 %. Dieser warmfeste Werkstoff wird für die Bearbeitung von Materialien mit höherer Festigkeit und bei langen Schnittkanälen mit entsprechend starker Erwärmung eingesetzt. Der Kobaltanteil von 5 % sorgt für eine höhere Warmfestigkeit, sowie für höhere Belastbarkeit.

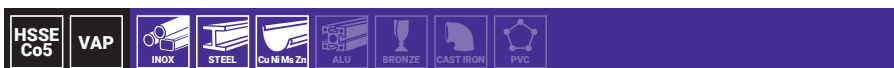

Maschinengewindebohrer aus kobaltlegiertem und vaporisiertem Schnellarbeitsstahl. Für Durchgangsgewinde und Sacklochgewinde, in unlegierte und legierte Stähle bis 1.000 N/mm<sup>2</sup> Festigkeit, VA-Metalle. Das Gewinde wird in einem Arbeitsgang geschnitten.

Mit "vaporisieren" ist das Aufdampfen einer nicht-metallischen Oxidschicht gemeint. Vaporisieren wirkt als Trennschicht und vermindert das Entstehen von Kaltaufschweißungen. Bei Kaltaufschweißungen handelt es sich um Werkstückspäne, die sich auf der Flanke des Gewindebohrers aufschweißen und das gefertigte Gewinde beschädigen. Folgen von Kaltaufschweißungen sind aufgerissene und unsaubere Gewindeflanken.

VAP verbessert die Haftung von Schmiermitteln an der Werkzeuoberfläche.





Maschinengewindebohrer aus Schnellarbeitsstahl mit Titan-Nitrid-Beschichtung. Universeller Einsatz für eine breite Werkstoffpalette durch Hartstoffschicht. Für Durchgangsgewinde und Sacklochgewinde, in unlegierte und legierte Stähle bis 900 N/mm<sup>2</sup> Festigkeit, VA-Metalle. Das Gewinde wird in einem Arbeitsgang geschnitten. Hinweis: Schnittgeschwindigkeiten ab 10 m/min.

Durch die TiN-Verschleißschutzbeschichtung erhöht sich die Oberflächenhärte auf ca. 2.500 HV. Titanitrid ist eine chemische Verbindung der beiden Elemente Titan und Stickstoff. TiN ist ein metallischer Hartstoff von typisch goldgelber Farbe. Vorteile: Höhere Härte, geringer Reibungskoeffizient, höhere Standzeit.

Kühlung ist nicht notwendig, wird aber empfohlen.



Maschinengewindebohrer aus Schnellarbeitsstahl. Für Durchgangsgewinde und Sacklochgewinde, in unlegierte, niedriglegierte, legierte Stähle bis 1.200 N/mm<sup>2</sup> Festigkeit und Guss. Das Gewinde wird in einem Arbeitsgang geschnitten.

Durch die TiAlN-Verschleißschutzbeschichtung erhöht sich die Oberflächenhärte auf ca. 3.500 HV. Titan-Aluminium-Nitrid ist eine chemische Verbindung der drei Elemente Titan, Aluminium und Stickstoff. TiAlN ist ein metallischer Hartstoff von typisch schwarz-violetter Farbe. Vorteile: Die TiAlN-Beschichtung ermöglicht die Trockenbearbeitung von Zerspanungswerkzeugen. Höhere Härte, sehr geringer Reibungskoeffizient, optimale Standzeiten.

Kühlung ist nicht notwendig.



## Technische Daten

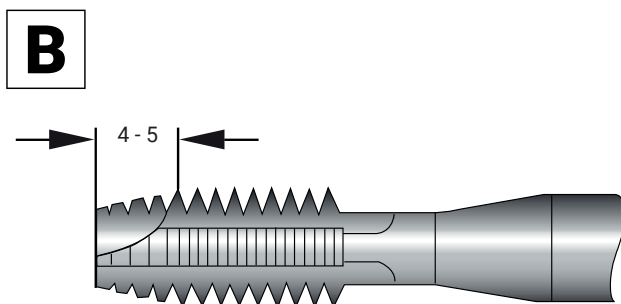

Form B ca. 4 - 5 Gänge mit Schälanschnitt

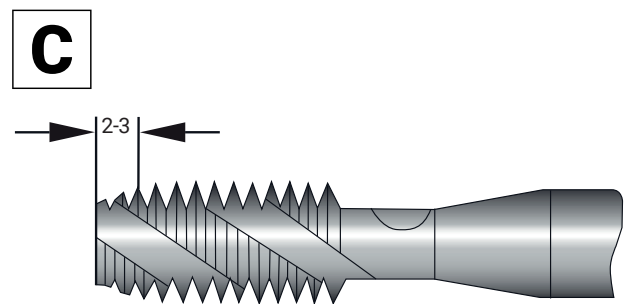

Form C / 35° RSP Rechtsspiralnut ca. 2 - 3 Gänge

**NEW** **ULTIMATECUT**®

# Kombi-Maschinengewindebohrer mit FLOWSTEP® Spitze

Er bleibt doppelt so lang für dich im Einsatz.  
Er macht dich 20 % schneller.  
Er spart dir Kraft.

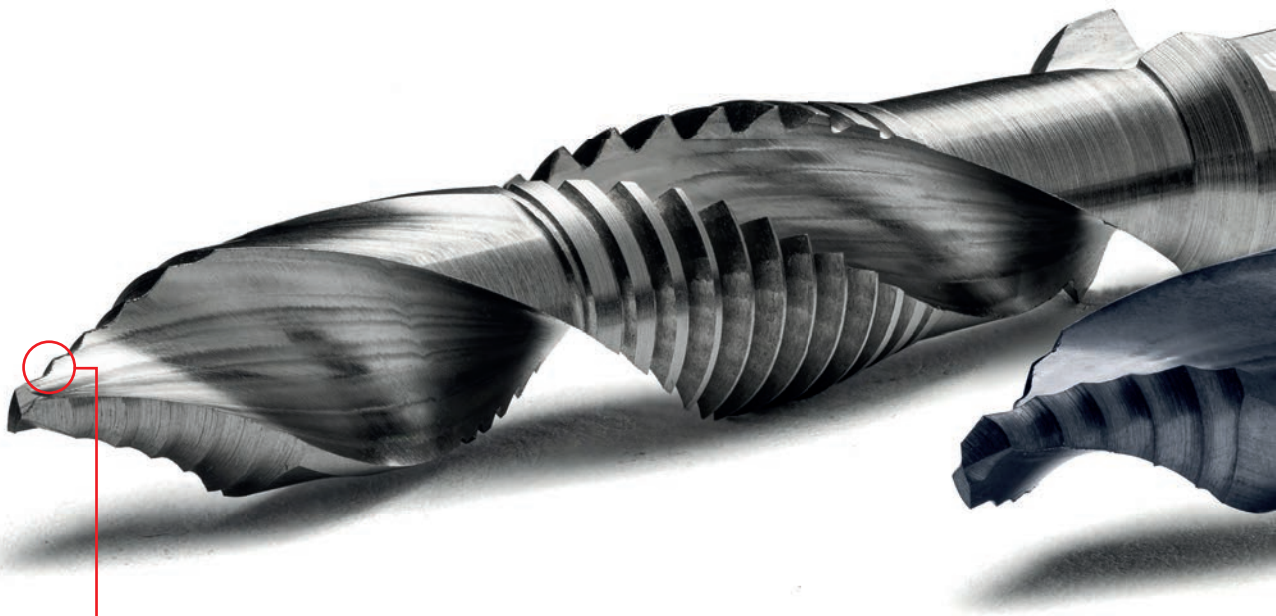

## **RUKO** FLOWSTEP® Spitze

Punktgenaues Zentrieren = kein Verrutschen beim Ansetzen.  
Zeitersparnis durch schnelleres Anbohren = mehr Bohrlöcher in derselben Zeit.  
Kräftesparendes Bohren = signifikant weniger Bohrerbruch.



### **RUKO** Bit-Schaft

Schneller Werkzeugwechsel = Effizientes Arbeiten

6 Flächen = Noch bessere Kraftübertragung und kein Durchrutschen

1/4"-Hexschaft = extrem flexibler Einsatz der Schaftaufnahme, kompatibel mit allen Hand- und Ständerbohrmaschinen mit 3-Backenfutter und allen gängigen Bit-Aufnahmen.



### **RUKO** 3-in-1-Power – Schneller, präziser, kräfteschonender

Bohren, Gewindeschneiden, Entgraten – ohne Werkzeugwechsel.  
3-fache Ersparnis – Zeit, Kosten und Gewicht.



**ULTIMATECUT®**

## ULTIMATECUT Kombi-Maschinengewindebohrer-Bit für Kernloch- und Durchgangsgewinde

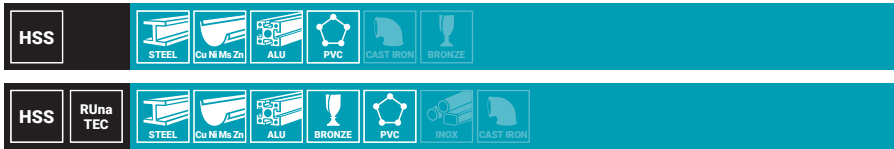

Der ULTIMATECUT Kombi-Maschinengewindebohrer eignet sich ideal für die Blechbearbeitung mit Rechts-/Linkslauf-Akkuschrauber. Die FLOWSTEP® Spitze ermöglicht eine perfekte Zentrierung ohne Anknörten.

Flanken: hinterschleifen  
 Schaft: 1/4" x 27,0 mm  
 Max. Materialstärke: 1 x M (z. B. M 10 = 10 mm Materialstärke)



**!** FLOWSTEP® Spitze ab M5, da aus technischer Anwendungssicht in den Größen kleiner M5 ohne Nutzenvorteil.

Verpackung: Kunststoff

06

Gewinde Nennmaß M	Steigung mm	L1 mm	Ø1 mm	HSS	HSS RUnaTEC	
M 3	0.50	51.00	2.5	270 614	270 614 P	1
M 4	0.70	54.00	3.3	270 615	270 615 P	1
M 5	0.80	57.00	4.2	270 616	270 616 P	1
M 6	1.00	63.00	5.0	270 617	270 617 P	1
M 8	1.25	72.00	6.8	270 618	270 618 P	1
M 10	1.50	80.00	8.5	270 619	270 619 P	1

		HSS	HSS RUnaTEC
<b>7</b> tfg./pcs.	ULTIMATECUT Kombi-Maschinengewindebohrer-Bit Satz  6 Kombi-Maschinengewindebohrer M 3   M 4   M 5   M 6   M 8   M 10 + 1 Sechskantmagnethalter	270 620 RO	270 620 PRO







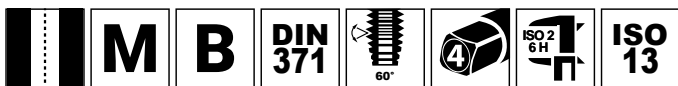

## Maschinengewindebohrer, metrisch, DIN 371 mit verstärktem Schaft für Durchgangsgewinde

HSSE Co5	TiAIN	HIGH STRENGTH	STEEL	INOX	STEEL	Cu Ni Ms Zn	ALU	PVC	CAST IRON	BRONZE	TITANIUM
HSSE Co5	VAP	INOX	STEEL	Cu Ni Ms Zn	ALU	PVC	BRONZE	CAST IRON			
HSSE Co5		INOX	STEEL	Cu Ni Ms Zn	ALU	PVC	BRONZE	CAST IRON			
HSS	TiN	STEEL	Cu Ni Ms Zn	PVC	INOX	CAST IRON	BRONZE				
HSS		STEEL	Cu Ni Ms Zn	ALU	PVC	CAST IRON	BRONZE				

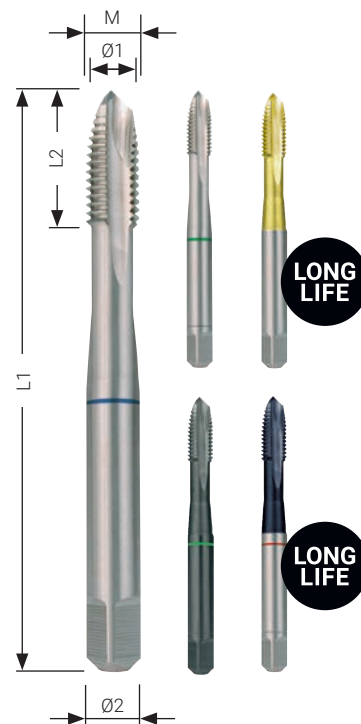

Anschnitt: Form B ca. 4 - 5 Gänge mit Schälanschnitt  
 Gewinde: metrisch DIN ISO 2  
 Flanken: hinterschliften

06

**!** Abbildung schematisch.  
 Kleinere Durchmesser können produktionsbedingt mit Spitze geliefert werden.

Verpackung: Kunststoff

Gewinde Nennmaß M	Steigung mm	Kernloch Ø1 mm	L1 mm	L2 max. mm	Ø2 mm
M 2	0.40	1.60	45.0	8.0	2.8
M 2.5	0.45	2.05	50.0	9.0	2.8
M 3	0.50	2.50	56.0	11.0	3.5
M 4	0.70	3.30	63.0	13.0	4.5
M 5	0.80	4.20	70.0	16.0	6.0
M 6	1.00	5.00	80.0	19.0	6.0
M 8	1.25	6.80	90.0	22.0	8.0
M 10	1.50	8.50	100.0	24.0	10.0

Ø2 mm	HSSE-Co 5 TiAIN	HSSE-Co 5 VAP	HSSE-Co 5	HSS TiN	HSS	
M 2	232 020 EF	232 020 VA	232 020 E	232 020 T	232 020	1
M 2.5	232 025 EF	232 025 VA	232 025 E	232 025 T	232 025	1
M 3	232 030 EF	232 030 VA	232 030 E	232 030 T	232 030	1
M 4	232 040 EF	232 040 VA	232 040 E	232 040 T	232 040	1
M 5	232 050 EF	232 050 VA	232 050 E	232 050 T	232 050	1
M 6	232 060 EF	232 060 VA	232 060 E	232 060 T	232 060	1
M 8	232 080 EF	232 080 VA	232 080 E	232 080 T	232 080	1
M 10	232 100 EF	232 100 VA	232 100 E	232 100 T	232 100	1

### **i** Anwendungstipp

Um die Standzeit zu erhöhen, Drehzahl reduzieren und RUKO Kühl- und Schmierstoffe verwenden.



## Maschinengewindebohrer, metrisch, DIN 371 mit verstärktem Schaft und Spiralnut 35° für Sacklochgewinde

HSSE Co5	TiAIN	STEEL	INOX	STEEL	Cu Ni Ms Zn	ALU	PVC	CAST IRON	BRONZE	TITANIUM
HSSE Co5	VAP	INOX	STEEL	Cu Ni Ms Zn	ALU	PVC	BRONZE	CAST IRON		
HSSE Co5		INOX	STEEL	Cu Ni Ms Zn	ALU	PVC	BRONZE	CAST IRON		
HSS	TiN	STEEL	Cu Ni Ms Zn	PVC	INOX	CAST IRON	BRONZE			
HSS		STEEL	Cu Ni Ms Zn	ALU	PVC	CAST IRON	BRONZE			



Anschnitt: Form C / 35° RSP ca. 2 - 3 Gänge

Gewinde: metrisch DIN ISO 13

Flanken: hinterschliffen

**!** **Abbildung schematisch.**  
**Kleinere Durchmesser können produktionsbedingt mit Spitze geliefert werden.**

Verpackung: Kunststoff

Gewinde Nennmaß M	Steigung mm	Kernloch Ø1 mm	L1 mm	L2 max. mm	Ø2 mm
M 2	0.40	1.60	45.0	8.0	2.8
M 2.5	0.45	2.05	50.0	9.0	2.8
M 3	0.50	2.50	56.0	11.0	3.5
M 4	0.70	3.30	63.0	13.0	4.5
M 5	0.80	4.20	70.0	16.0	6.0
M 6	1.00	5.00	80.0	19.0	6.0
M 8	1.25	6.80	90.0	22.0	8.0
M 10	1.50	8.50	100.0	24.0	10.0

Ø2 mm	HSSE-Co 5 TiAIN	HSSE-Co 5 VAP	HSSE-Co 5	HSS TiN	HSS	
M 2	234 020 EF	234 020 VA	234 020 E	234 020 T	234 020	1
M 2.5	234 025 EF	234 025 VA	234 025 E	234 025 T	234 025	1
M 3	234 030 EF	234 030 VA	234 030 E	234 030 T	234 030	1
M 4	234 040 EF	234 040 VA	234 040 E	234 040 T	234 040	1
M 5	234 050 EF	234 050 VA	234 050 E	234 050 T	234 050	1
M 6	234 060 EF	234 060 VA	234 060 E	234 060 T	234 060	1
M 8	234 080 EF	234 080 VA	234 080 E	234 080 T	234 080	1
M 10	234 100 EF	234 100 VA	234 100 E	234 100 T	234 100	1



## Maschinengewindebohrer, metrisch, DIN 376 mit Überlaufschaft für Durchgangsgewinde



Anschnitt: Form B ca. 4 - 5 Gänge mit Schälanschnitt  
 Gewinde: metrisch DIN ISO 13  
 Flanken: hinterschliffen

06

**!** Abbildung schematisch.  
 Kleinere Durchmesser können produktionsbedingt mit Spitze geliefert werden.

Verpackung: Kunststoff

Gewinde Nennmaß M	Steigung mm	Kernloch Ø1 mm	L1 mm	L2 max. mm	Ø2 mm
M 3	0.50	2.50	56.0	11.0	2.2
M 4	0.70	3.30	63.0	13.0	2.8
M 5	0.80	4.20	70.0	16.0	3.5
M 6	1.00	5.00	80.0	19.0	4.5
M 8	1.25	6.80	90.0	22.0	6.0
M 10	1.50	8.50	100.0	24.0	7.0
M 12	1.75	10.20	110.0	28.0	9.0
M 14	2.00	12.00	110.0	30.0	11.0
M 16	2.00	14.00	110.0	32.0	12.0
M 18	2.50	15.50	125.0	34.0	14.0
M 20	2.50	17.50	140.0	34.0	16.0
M 22	2.50	19.50	140.0	34.0	18.0
M 24	3.00	21.00	160.0	38.0	18.0
M 27	3.00	24.00	160.0	38.0	20.0
M 30	3.50	26.50	180.0	45.0	22.0

Ø2 mm	HSSE-Co 5 TiAlN	HSSE-Co 5 VAP	HSSE-Co 5	HSS TiN	HSS	
M 3	232 031 EF	232 031 VA	232 031 E	—	—	1
M 4	232 041 EF	232 041 VA	232 041 E	—	—	1
M 5	232 051 EF	232 051 VA	232 051 E	—	—	1
M 6	232 061 EF	232 061 VA	232 061 E	—	—	1
M 8	232 081 EF	232 081 VA	232 081 E	—	—	1
M 10	232 101 EF	232 101 VA	232 101 E	—	—	1
M 12	232 120 EF	232 120 VA	232 120 E	232 120 T	232 120	1
M 14	232 140 EF	232 140 VA	232 140 E	232 140 T	232 140	1
M 16	232 160 EF	232 160 VA	232 160 E	232 160 T	232 160	1
M 18	232 180 EF	232 180 VA	232 180 E	232 180 T	232 180	1
M 20	232 200 EF	232 200 VA	232 200 E	232 200 T	232 200	1
M 22	232 220 EF	232 220 VA	232 220 E	232 220 T	232 220	1
M 24	232 240 EF	232 240 VA	232 240 E	232 240 T	232 240	1
M 27	232 270 EF	232 270 VA	232 270 E	232 270 T	232 270	1
M 30	232 300 EF	232 300 VA	232 300 E	232 300 T	232 300	1



## Maschinengewindebohrer, metrisch, DIN 376 mit Überlaufschaft und Spiralnut 35° für Sacklochgewinde



Anschnitt: Form C / 35° RSP ca. 2 - 3 Gänge

Gewinde: metrisch DIN ISO 13

Flanken: hinterschleifen

**!** Abbildung schematisch.  
Kleinere Durchmesser können produktionsbedingt mit Spitze geliefert werden.

Verpackung: Kunststoff

Gewinde Nennmaß M	Steigung mm	Kernloch Ø1 mm	L1 mm	L2 max. mm	Ø2 mm
M 3	0.50	2.50	56.0	11.0	2.2
M 4	0.70	3.30	63.0	13.0	2.8
M 5	0.80	4.20	70.0	16.0	3.5
M 6	1.00	5.00	80.0	19.0	4.5
M 8	1.25	6.80	90.0	22.0	6.0
M 10	1.50	8.50	100.0	24.0	7.0
M 12	1.75	10.20	110.0	28.0	9.0
M 14	2.00	12.00	110.0	30.0	11.0
M 16	2.00	14.00	110.0	32.0	12.0
M 18	2.50	15.50	125.0	34.0	14.0
M 20	2.50	17.50	140.0	34.0	16.0
M 22	2.50	19.50	140.0	34.0	18.0
M 24	3.00	21.00	160.0	38.0	18.0
M 27	3.00	24.00	160.0	38.0	20.0
M 30	3.50	26.50	180.0	45.0	22.0

Ø2 mm	HSSE-Co 5 TiAlN	HSSE-Co 5 VAP	HSSE-Co 5	HSS TiN	HSS	
M 3	233 030 EF	233 030 VA	233 030 E	—	—	1
M 4	233 040 EF	233 040 VA	233 040 E	—	—	1
M 5	233 050 EF	233 050 VA	233 050 E	—	—	1
M 6	233 060 EF	233 060 VA	233 060 E	—	—	1
M 8	233 080 EF	233 080 VA	233 080 E	—	—	1
M 10	233 100 EF	233 100 VA	233 100 E	—	—	1
M 12	233 120 EF	233 120 VA	233 120 E	233 120 T	233 120	1
M 14	233 140 EF	233 140 VA	233 140 E	233 140 T	233 140	1
M 16	233 160 EF	233 160 VA	233 160 E	233 160 T	233 160	1
M 18	233 180 EF	233 180 VA	233 180 E	233 180 T	233 180	1
M 20	233 200 EF	233 200 VA	233 200 E	233 200 T	233 200	1
M 22	233 220 EF	233 220 VA	233 220 E	233 220 T	233 220	1
M 24	233 240 EF	233 240 VA	233 240 E	233 240 T	233 240	1
M 27	233 270 EF	233 270 VA	233 270 E	233 270 T	233 270	1
M 30	233 300 EF	233 300 VA	233 300 E	233 300 T	233 300	1



## Maschinengewindebohrer-Sätze, metrisch, DIN 371/376



245 057 RO

06

		HSSE-Co 5 TiAIN	HSSE-Co 5 VAP	HSSE-Co 5	HSS TiN	HSS
<b>7</b> Stk./pcs.	Maschinengewindebohrer M DIN 371 / 376 Form B mit Schälanschnitt M 3   M 4   M 5   M 6   M 8   M 10   M 12	245 068 RO	245 063 RO	245 061 RO	245 065 RO	245 057 RO
<b>7</b> Stk./pcs.	Maschinengewindebohrer M DIN 371 / 376 Form C / 35° RSP M 3   M 4   M 5   M 6   M 8   M 10   M 12	245 069 RO	245 064 RO	245 062 RO	245 066 RO	245 058 RO

## Maschinengewindebohrer- und Spiralbohrer-Satz, metrisch



		HSSE-Co 5
<b>21</b> Stk./pcs.	Maschinengewindebohrer M DIN 371 / 376 HSSE-Co 5 Form B mit Schälanschnitt M 3   M 4   M 5   M 6   M 8   M 10   M 12	245 054
	Maschinengewindebohrer M DIN 371 / 376 HSSE-Co 5 Form C / 35° RSP M 3   M 4   M 5   M 6   M 8   M 10   M 12	
	Spiralbohrer DIN 338 Typ VA, HSSE-Co 5 Ø 2.5   3.3   4.2   5.0   6.8   8.5   10.2 mm	



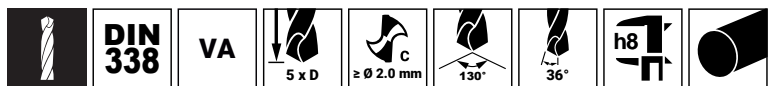
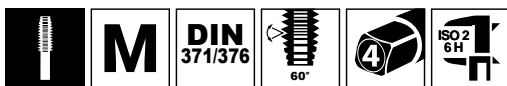

## Maschinengewindebohrer- und Spiralbohrer-Sätze, metrisch



		HSSE-Co 5
<b>14</b> tlg./pcs.	Maschinengewindebohrer M DIN 371 / 376 HSSE-Co 5 Form B mit Schälanschnitt M 3   M 4   M 5   M 6   M 8   M 10   M 12  Spiralbohrer DIN 338 Typ VA, HSSE-Co 5 Ø 2.5   3.3   4.2   5.0   6.8   8.5   10.2 mm	245 051 RO
<b>14</b> tlg./pcs.	Maschinengewindebohrer M DIN 371 / 376 HSSE-Co 5 Form C / 35° RSP M 3   M 4   M 5   M 6   M 8   M 10   M 12  Spiralbohrer DIN 338 Typ VA, HSSE-Co 5 Ø 2.5   3.3   4.2   5.0   6.8   8.5   10.2 mm	245 052 RO



245 052 RO

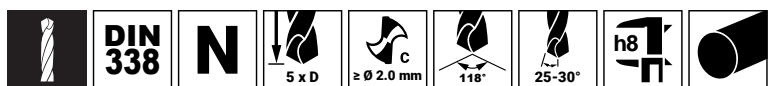

## Maschinengewindebohrer- und Spiralbohrer-Sätze, metrisch



		HSS
<b>14</b> tlg./pcs.	Maschinengewindebohrer M DIN 371 / 376 HSS Form B mit Schälanschnitt M 3   M 4   M 5   M 6   M 8   M 10   M 12  Spiralbohrer DIN 338 Typ N, HSS Ø 2.5   3.3   4.2   5.0   6.8   8.5   10.2 mm	245 048 RO
<b>14</b> tlg./pcs.	Maschinengewindebohrer M DIN 371 / 376 HSS Form C / 35° RSP M 3   M 4   M 5   M 6   M 8   M 10   M 12  Spiralbohrer DIN 338 Typ N, HSS Ø 2.5   3.3   4.2   5.0   6.8   8.5   10.2 mm	245 049 RO



245 048 RO

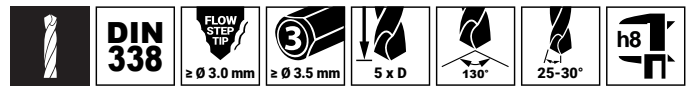
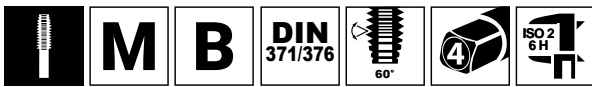

## Maschinengewindebohrer- und ULTIMATECUT Spiralbohrer Typ FLOWSTEP®-Satz

**ULTIMATECUT®**



		HSSE-Co 5
<b>14</b> tfg./pcs.	<p>Maschinengewindebohrer M DIN 371 / 376 HSSE-Co 5 Form B mit Schälanschnitt M 3   M 4   M 5   M 6   M 8   M 10   M 12</p> <p>ULTIMATECUT Spiralbohrer DIN 338 Typ FLOWSTEP® HSSE-Co 5, geschliffen Ø 2.5   3.3   4.2   5.0   6.8   8.5   10.2 mm</p>	259 048 ERO



06

## Maschinengewindebohrer- und ULTIMATECUT Spiralbohrer Typ FLOWSTEP®-Satz

**ULTIMATECUT®**



		HSS
<b>14</b> tfg./pcs.	<p>Maschinengewindebohrer M DIN 371 / 376 HSS Form B mit Schälanschnitt M 3   M 4   M 5   M 6   M 8   M 10   M 12</p> <p>ULTIMATECUT Spiralbohrer DIN 338 Typ FLOWSTEP® HSS, geschliffen Ø 2.5   3.3   4.2   5.0   6.8   8.5   10.2 mm</p>	259 048 RO







## Maschinengewindebohrer, metrisch, DIN 371 mit verstärktem Schaft für Durchgangsgewinde und ausgesetzten Zähnen



Anschnitt: Form B - AZ ca. 4 - 5 Gänge mit Schälanschnitt und ausgesetzten Zähnen  
 Gewinde: metrisch DIN ISO 13  
 Flanken: hinterschleifen

**!** **Abbildung schematisch.**  
 Kleinere Durchmesser können produktionsbedingt mit Spitze geliefert werden.

Verpackung: Kunststoff

Gewinde Nennmaß M	Steigung mm	Kernloch Ø1 mm	L1 mm	L2 max. mm	Ø2 mm	HSS	
M 3	0.50	2.50	56.0	11.0	3.5	272 030	1
M 4	0.70	3.30	63.0	13.0	4.5	272 040	1
M 5	0.80	4.20	70.0	16.0	6.0	272 050	1
M 6	1.00	5.00	80.0	19.0	6.0	272 060	1
M 8	1.25	6.80	90.0	22.0	8.0	272 080	1
M 10	1.50	8.50	100.0	24.0	10.0	272 100	1



## Maschinengewindebohrer, metrisch, DIN 376 mit Überlaufschaft für Durchgangsgewinde, mit ausgesetzten Zähnen



Anschnitt: Form B - AZ ca. 4 - 5 Gänge mit Schälanschnitt und ausgesetzten Zähnen  
 Gewinde: metrisch DIN ISO 13  
 Flanken: hinterschleifen

Verpackung: Kunststoff

Gewinde Nennmaß M	Steigung mm	Kernloch Ø1 mm	L1 mm	L2 max. mm	Ø2 mm	HSS	
M 12	1.75	10.20	110.0	28.0	9.0	272 120	1
M 14	2.00	12.00	110.0	30.0	11.0	272 140	1
M 16	2.00	14.00	110.0	32.0	12.0	272 160	1
M 18	2.50	15.50	125.0	34.0	14.0	272 180	1
M 20	2.50	17.50	140.0	34.0	16.0	272 200	1
M 22	2.50	19.50	140.0	34.0	18.0	272 220	1
M 24	3.00	21.00	160.0	38.0	18.0	272 240	1

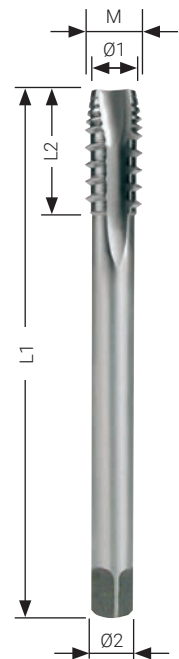



## Maschinengewindebohrer, metrisch, DIN 371 mit verstärktem Schaft für Durchgangsgewinde

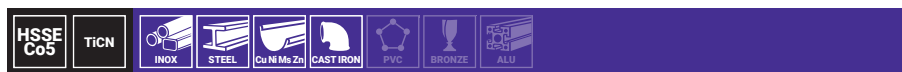

Anschnitt: Form C / ca. 2 - 3 Gänge  
 Gewinde: metrisch DIN ISO 13  
 Flanken: hinterschliffen

**!** **Abbildung schematisch.**  
**Kleinere Durchmesser können produktionsbedingt mit Spitze geliefert werden.**

Verpackung: Kunststoff



Gewinde Nennmaß M	Steigung mm	Kernloch Ø1 mm	L1 mm	L2 max. mm	Ø2 mm	HSSE-Co 5 TiCN	
M 3	0.50	2.50	56.0	11.0	3.5	273 030 ETC	1
M 4	0.70	3.30	63.0	13.0	4.5	273 040 ETC	1
M 5	0.80	4.20	70.0	16.0	6.0	273 050 ETC	1
M 6	1.00	5.00	80.0	19.0	6.0	273 060 ETC	1
M 8	1.25	6.80	90.0	22.0	8.0	273 080 ETC	1
M 10	1.50	8.50	100.0	24.0	10.0	273 100 ETC	1



## Maschinengewindebohrer, metrisch, DIN 376 mit Überlaufschaft für Durchgangsgewinde

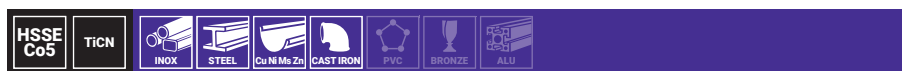

Anschnitt: Form C / ca. 2 - 3 Gänge  
 Gewinde: metrisch DIN ISO 13  
 Flanken: hinterschliffen

**!** **Abbildung schematisch.**  
**Kleinere Durchmesser können produktionsbedingt mit Spitze geliefert werden.**

Verpackung: Kunststoff



Gewinde Nennmaß M	Steigung mm	Kernloch Ø1 mm	L1 mm	L2 max. mm	Ø2 mm	HSSE-Co 5 TiCN	
M 12	1.75	10.20	110.0	28.0	9.0	273 120 ETC	1
M 14	2.00	12.00	110.0	30.0	11.0	273 140 ETC	1
M 16	2.00	14.00	110.0	32.0	12.0	273 160 ETC	1
M 18	2.50	15.50	125.0	34.0	14.0	273 180 ETC	1
M 20	2.50	17.50	140.0	34.0	16.0	273 200 ETC	1
M 22	2.50	19.50	140.0	34.0	18.0	273 220 ETC	1
M 24	3.00	21.00	160.0	38.0	18.0	273 240 ETC	1



# Maschinengewindebohrer, metrisch fein, DIN 374 mit Überlaufschaft für Durchgangsgewinde



Anschnitt: Form B ca. 4 - 5 Gänge mit Schälanschnitt  
 Gewinde: metrisch fein DIN ISO 13  
 Flanken: hinterschleifen

**! Abbildung schematisch. Kleinere Durchmesser können produktionsbedingt mit Spitze geliefert werden.**

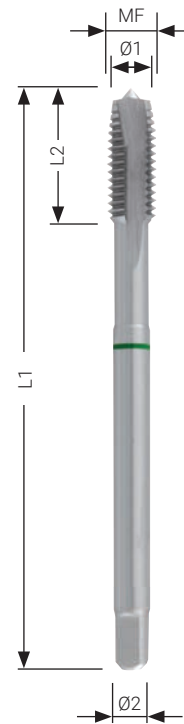

Verpackung: Kunststoff

Gewinde Nennmaß MF	Steigung mm	Kernloch Ø1 mm	L1 mm	L2 max. mm	Ø2 mm	HSSE-Co 5	
MF 4	0.50	3.50	63.0	10.0	2.8	260 041 E	1
MF 5	0.50	4.50	70.0	12.0	3.5	260 050 E	1
MF 6	0.75	5.20	80.0	14.0	4.5	260 060 E	1
MF 8	1.00	7.00	90.0	22.0	6.0	260 081 E	1
MF 10	1.00	9.00	90.0	20.0	7.0	260 100 E	1
MF 10	1.25	8.80	100.0	24.0	7.0	260 101 E	1
MF 12	1.00	11.00	100.0	20.0	9.0	260 122 E	1
MF 12	1.25	10.80	100.0	22.0	9.0	260 121 E	1
MF 12	1.50	10.50	100.0	22.0	9.0	260 120 E	1
MF 14	1.00	13.00	100.0	20.0	11.0	260 142 E	1
MF 14	1.25	12.80	100.0	22.0	11.0	260 143 E	1
MF 14	1.50	12.50	100.0	22.0	11.0	260 141 E	1
MF 16	1.00	15.00	100.0	20.0	12.0	260 161 E	1
MF 16	1.50	14.50	100.0	22.0	12.0	260 160 E	1
MF 18	1.00	17.00	110.0	25.0	14.0	260 181 E	1
MF 18	1.50	16.50	110.0	25.0	14.0	260 180 E	1
MF 18	2.00	16.00	125.0	34.0	14.0	260 182 E	1
MF 20	1.00	19.00	125.0	25.0	16.0	260 201 E	1
MF 20	1.50	18.50	125.0	25.0	16.0	260 200 E	1
MF 20	2.00	18.00	140.0	34.0	16.0	260 202 E	1
MF 22	1.50	20.50	125.0	25.0	18.0	260 220 E	1
MF 22	2.00	20.00	140.0	34.0	18.0	260 222 E	1
MF 24	1.00	23.00	140.0	28.0	18.0	260 242 E	1
MF 24	1.50	22.50	140.0	28.0	18.0	260 240 E	1
MF 24	2.00	22.00	140.0	28.0	18.0	260 241 E	1
MF 28	1.50	26.50	140.0	28.0	20.0	260 281 E	1
MF 28	2.00	26.00	140.0	28.0	20.0	260 282 E	1
MF 30	1.50	28.50	150.0	28.0	22.0	260 301 E	1
MF 30	2.00	28.00	150.0	28.0	22.0	260 302 E	1





# Maschinengewindebohrer, metrisch fein, DIN 374 mit Überlaufschaft und Rechtsspiralnuten 35° für Sacklochgewinde



Anschnitt: Form C / 35° RSP ca. 2 - 3 Gänge  
 Gewinde: metrisch fein DIN ISO 13  
 Flanken: hinterschleifen

**!** **Abbildung schematisch.**  
**Kleinere Durchmesser können produktionsbedingt mit Spitze geliefert werden.**

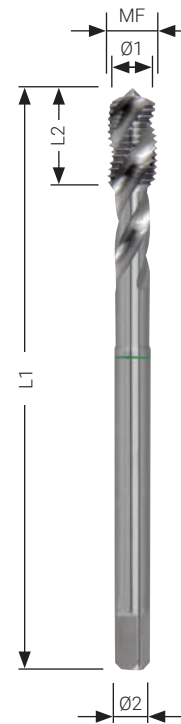

Verpackung: Kunststoff

Gewinde Nennmaß MF	Steigung mm	Kernloch Ø1 mm	L1 mm	L2 max. mm	Ø2 mm	HSSE-Co 5	
MF 4	0.50	3.50	63.0	10.0	2.8	261 041 E	1
MF 5	0.50	4.50	70.0	12.0	3.5	261 050 E	1
MF 6	0.75	5.20	80.0	14.0	4.5	261 060 E	1
MF 8	1.00	7.00	90.0	22.0	6.0	261 081 E	1
MF 10	1.00	9.00	90.0	20.0	7.0	261 100 E	1
MF 10	1.25	8.80	100.0	24.0	7.0	261 101 E	1
MF 12	1.00	11.00	100.0	20.0	9.0	261 122 E	1
MF 12	1.25	10.80	100.0	22.0	9.0	261 121 E	1
MF 12	1.50	10.50	100.0	22.0	9.0	261 120 E	1
MF 14	1.00	13.00	100.0	20.0	11.0	261 142 E	1
MF 14	1.25	12.80	100.0	22.0	11.0	261 143 E	1
MF 14	1.50	12.50	100.0	22.0	11.0	261 141 E	1
MF 16	1.00	15.00	100.0	20.0	12.0	261 161 E	1
MF 16	1.50	14.50	100.0	22.0	12.0	261 160 E	1
MF 18	1.00	17.00	110.0	25.0	14.0	261 181 E	1
MF 18	1.50	16.50	110.0	25.0	14.0	261 180 E	1
MF 18	2.00	16.00	125.0	34.0	14.0	261 182 E	1
MF 20	1.00	19.00	125.0	25.0	16.0	261 201 E	1
MF 20	1.50	18.50	125.0	25.0	16.0	261 200 E	1
MF 20	2.00	18.00	140.0	34.0	16.0	261 202 E	1
MF 22	1.50	20.50	125.0	25.0	18.0	261 220 E	1
MF 22	2.00	20.00	140.0	34.0	18.0	261 222 E	1
MF 24	1.00	23.00	140.0	28.0	18.0	261 242 E	1
MF 24	1.50	22.50	140.0	28.0	18.0	261 240 E	1
MF 24	2.00	22.00	140.0	28.0	18.0	261 241 E	1
MF 28	1.50	26.50	140.0	28.0	20.0	261 281 E	1
MF 28	2.00	26.00	140.0	28.0	20.0	261 282 E	1
MF 30	1.50	28.50	150.0	28.0	22.0	261 301 E	1
MF 30	2.00	28.00	150.0	28.0	22.0	261 302 E	1

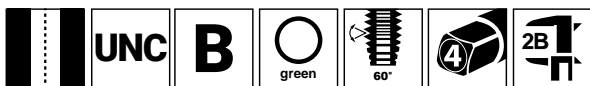

## Maschinengewindebohrer UNC mit verstärktem Schaft für Durchgangsgewinde



Anschnitt: Form B ca. 4 - 5 Gänge mit Schälanschnitt  
 Gewinde: amerikanisches Grobgewinde UNC  
 Flanken: hinterschleifen

**!** **Abbildung schematisch.**  
**Kleinere Durchmesser können produktionsbedingt mit Spitze geliefert werden.**

Verpackung: Kunststoff

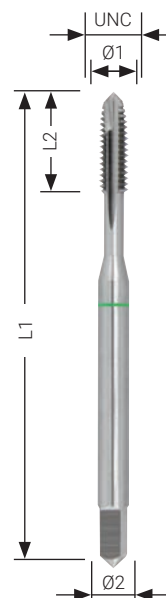

Nennmaß UNC	Gangzahl pro Zoll	Kernloch Ø1 mm	L1 mm	L2 mm	Ø2 mm	HSSE-Co 5	
Nr. 4	40	2.3	56.0	11.0	3.5	265 040 UNC	1
Nr. 5	40	2.6	56.0	11.0	3.5	265 050 UNC	1
Nr. 6	32	2.8	56.0	13.0	4.0	265 060 UNC	1
Nr. 8	32	3.5	63.0	13.0	4.5	265 080 UNC	1
Nr. 10	24	3.8	70.0	16.0	6.0	265 100 UNC	1
Nr. 12	24	4.5	70.0	16.0	6.0	265 120 UNC	1
1/4"	20	5.1	80.0	17.0	7.0	265 014 UNC	1
5/16"	18	6.5	90.0	20.0	8.0	265 516 UNC	1
3/8"	16	8.0	100.0	22.0	9.0	265 038 UNC	1



## Maschinengewindebohrer UNC mit Überlaufschaft für Durchgangsgewinde



Anschnitt: Form B ca. 4 - 5 Gänge mit Schälanschnitt  
 Gewinde: amerikanisches Grobgewinde UNC  
 Flanken: hinterschleifen

**!** **Abbildung schematisch.**  
**Kleinere Durchmesser können produktionsbedingt mit Spitze geliefert werden.**

Verpackung: Kunststoff

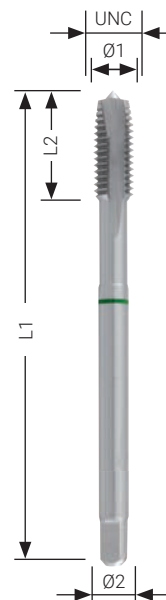

Nennmaß UNC	Gangzahl pro Zoll	Kernloch Ø1 mm	L1 mm	L2 mm	Ø2 mm	HSSE-Co 5	
7/16"	14	9.3	100.0	22.0	8.0	265 716 UNC	1
1/2"	13	10.8	110.0	25.0	9.0	265 012 UNC	1
9/16"	12	12.2	110.0	26.0	11.0	265 916 UNC	1
5/8"	11	13.5	110.0	27.0	12.0	265 058 UNC	1
3/4"	10	16.5	125.0	30.0	14.0	265 034 UNC	1
7/8"	9	19.3	140.0	32.0	18.0	265 078 UNC	1
1"	8	22.2	160.0	36.0	18.0	265 010 UNC	1

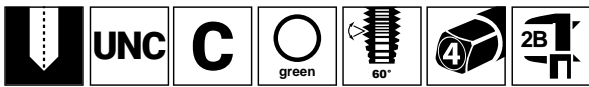

## Maschinengewindebohrer UNC mit verstärktem Schaft und Spiralnut 35° für Sacklochgewinde



Anschnitt: Form C / 35° RSP ca. 2 - 3 Gänge  
Gewinde: amerikanisches Grobgewinde UNC  
Flanken: hinterschleifen

**!** Abbildung schematisch.  
Kleinere Durchmesser können produktionsbedingt mit Spitze geliefert werden.

Verpackung: Kunststoff

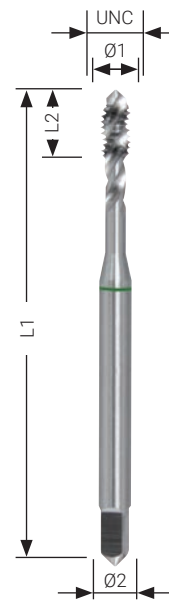

06

Nennmaß UNC	Gangzahl pro Zoll	Kernloch Ø1 mm	L1 mm	L2 mm	Ø2 mm	HSSE-Co 5	
Nr. 4	40	2.3	56.0	7.0	3.5	266 040 UNC	1
Nr. 5	40	2.6	56.0	7.0	3.5	266 050 UNC	1
Nr. 6	32	2.8	56.0	8.0	4.0	266 060 UNC	1
Nr. 8	32	3.5	63.0	8.0	4.5	266 080 UNC	1
Nr. 10	24	3.8	70.0	10.0	6.0	266 100 UNC	1
Nr. 12	24	4.5	70.0	10.0	6.0	266 120 UNC	1
1/4"	20	5.1	80.0	13.0	7.0	266 014 UNC	1
5/16"	18	6.5	90.0	14.0	8.0	266 516 UNC	1
3/8"	16	8.0	100.0	16.0	10.0	266 038 UNC	1

## Maschinengewindebohrer UNC mit Überlaufschaft und Spiralnut 35° für Sacklochgewinde



Anschnitt: Form C / 35° RSP ca. 2 - 3 Gänge  
Gewinde: amerikanisches Grobgewinde UNC  
Flanken: hinterschleifen

**!** Abbildung schematisch.  
Kleinere Durchmesser können produktionsbedingt mit Spitze geliefert werden.

Verpackung: Kunststoff

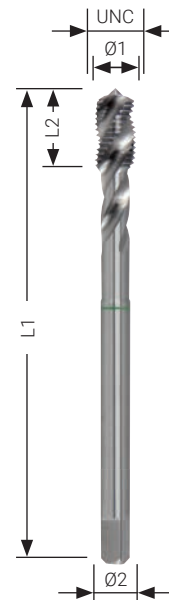

Nennmaß UNC	Gangzahl pro Zoll	Kernloch Ø1 mm	L1 mm	L2 mm	Ø2 mm	HSSE-Co 5	
7/16"	14	9.3	100.0	17.0	8.0	266 716 UNC	1
1/2"	13	10.8	110.0	20.0	9.0	266 012 UNC	1
9/16"	12	12.2	110.0	20.0	11.0	266 916 UNC	1
5/8"	11	13.5	110.0	22.0	12.0	266 058 UNC	1
3/4"	10	16.5	125.0	25.0	14.0	266 034 UNC	1
7/8"	9	19.3	140.0	27.0	18.0	266 078 UNC	1
1"	8	22.2	160.0	30.0	18.0	266 010 UNC	1

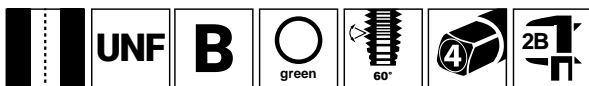

## Maschinengewindebohrer UNF mit verstärktem Schaft für Durchgangsgewinde



Anschnitt: Form B ca. 4 - 5 Gänge mit Schälanschnitt  
 Gewinde: amerikanisches Feingewinde UNF  
 Flanken: hinterschliffen

**!** Abbildung schematisch.  
 Kleinere Durchmesser können produktionsbedingt mit Spitze geliefert werden.

Verpackung: Kunststoff

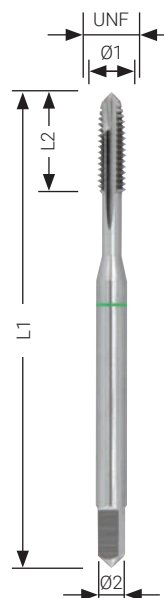

Nennmaß UNF	Gangzahl pro Zoll	Kernloch Ø1 mm	L1 mm	L2 mm	Ø2 mm	HSSE-Co 5	
Nr. 4	48	2.40	56.0	11.0	3.5	265 040 UNF	1
Nr. 5	44	2.70	56.0	11.0	3.5	265 050 UNF	1
Nr. 6	40	2.95	56.0	13.0	4.0	265 060 UNF	1
Nr. 8	36	3.50	63.0	13.0	4.5	265 080 UNF	1
Nr. 10	32	4.10	70.0	16.0	6.0	265 100 UNF	1
Nr. 12	28	4.60	70.0	16.0	6.0	265 120 UNF	1
1/4"	28	5.50	80.0	17.0	7.0	265 014 UNF	1
5/16"	24	6.60	90.0	17.0	8.0	265 516 UNF	1
3/8"	24	8.50	100.0	18.0	10.0	265 038 UNF	1



## Maschinengewindebohrer UNF mit Überlaufschaft für Durchgangsgewinde



Anschnitt: Form B ca. 4 - 5 Gänge mit Schälanschnitt  
 Gewinde: amerikanisches Feingewinde UNF  
 Flanken: hinterschliffen

**!** Abbildung schematisch.  
 Kleinere Durchmesser können produktionsbedingt mit Spitze geliefert werden.

Verpackung: Kunststoff

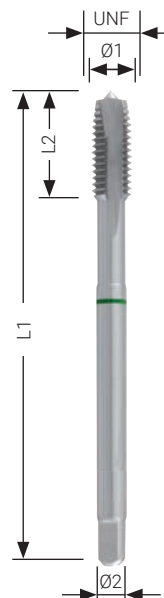

Nennmaß UNF	Gangzahl pro Zoll	Kernloch Ø1 mm	L1 mm	L2 mm	Ø2 mm	HSSE-Co 5	
7/16"	20	9.90	100.0	22.0	8.0	265 716 UNF	1
1/2"	20	11.50	100.0	22.0	9.0	265 012 UNF	1
9/16"	18	12.90	100.0	22.0	11.0	265 916 UNF	1
5/8"	18	14.50	100.0	22.0	12.0	265 058 UNF	1
3/4"	16	17.50	110.0	25.0	14.0	265 034 UNF	1
7/8"	14	20.50	140.0	26.0	18.0	265 078 UNF	1
1"	12	23.25	150.0	28.0	18.0	265 010 UNF	1

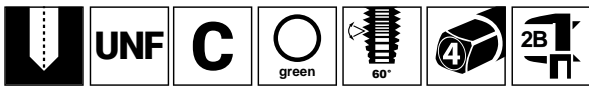

## Maschinengewindebohrer UNF mit verstärktem Schaft und Spiralnut 35° für Sacklochgewinde



Anschnitt: Form C / 35° RSP ca. 2 - 3 Gänge  
Gewinde: amerikanisches Feingewinde UNF  
Flanken: hinterschleifen

**!** Abbildung schematisch.  
Kleinere Durchmesser können produktionsbedingt mit Spitze geliefert werden.

Verpackung: Kunststoff

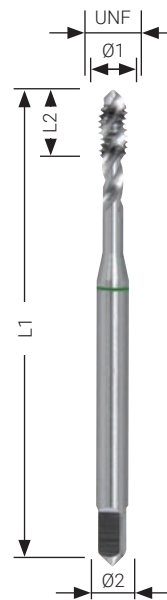

Nennmaß UNF	Gangzahl pro Zoll	Kernloch Ø1 mm	L1 mm	L2 mm	Ø2 mm	HSSE-Co 5	
Nr. 4	48	2.40	56.0	5.5	3.5	266 040 UNF	1
Nr. 5	44	2.70	56.0	6.0	3.5	266 050 UNF	1
Nr. 6	40	2.95	56.0	7.0	4.0	266 060 UNF	1
Nr. 8	36	3.50	63.0	7.5	4.5	266 080 UNF	1
Nr. 10	32	4.10	70.0	8.0	6.0	266 100 UNF	1
Nr. 12	28	4.60	70.0	9.0	6.0	266 120 UNF	1
1/4	28	5.50	80.0	10.0	7.0	266 014 UNF	1
5/16	24	6.90	90.0	10.0	8.0	266 516 UNF	1
3/8	24	8.50	100.0	10.0	10.0	266 038 UNF	1

## Maschinengewindebohrer UNF mit Überlaufschaft und Spiralnut 35° für Sacklochgewinde



Anschnitt: Form C / 35° RSP ca. 2 - 3 Gänge  
Gewinde: amerikanisches Feingewinde UNF  
Flanken: hinterschleifen

**!** Abbildung schematisch.  
Kleinere Durchmesser können produktionsbedingt mit Spitze geliefert werden.

Verpackung: Kunststoff

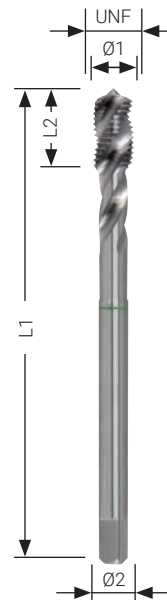

Nennmaß UNF	Gangzahl pro Zoll	Kernloch Ø1 mm	L1 mm	L2 mm	Ø2 mm	HSSE-Co 5	
7/16"	20	9.90	100.0	13.0	8.0	266 716 UNF	1
1/2"	20	11.50	100.0	13.0	9.0	266 012 UNF	1
9/16"	18	12.90	100.0	15.0	11.0	266 916 UNF	1
5/8"	18	14.50	100.0	15.0	12.0	266 058 UNF	1
3/4"	16	17.50	110.0	17.0	14.0	266 034 UNF	1
7/8"	14	20.50	140.0	17.0	18.0	266 078 UNF	1
1"	12	23.25	150.0	20.0	18.0	266 010 UNF	1





## Maschinengewindebohrer PG DIN 40430 mit Überlaufschaft, für Durchgangsgewinde



Anschnitt: Form B - AZ ca. 4 - 5 Gänge mit Schälanschnitt und ausgesetzten Zähnen  
 Gewinde: Stahlpanzerrohrgewinde DIN 40 430  
 Flanken: hinterschliffen

**Abbildung schematisch.**  
 Kleinere Durchmesser können produktionsbedingt mit Spitze geliefert werden.

Verpackung: Kunststoff

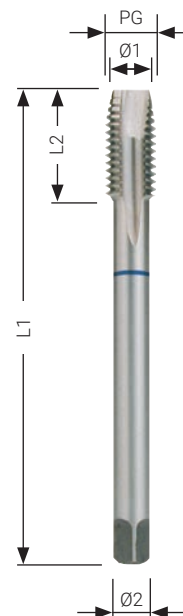

Nennmaß PG	Gangzahl pro Zoll	Kernloch Ø1 mm	L1 mm	L2 mm	Ø2 mm	HSS	
PG 7	20	11.35	70.0	22.0	9.0	264 007	1
PG 9	18	13.95	70.0	22.0	12.0	264 009	1
PG 11	18	17.35	80.0	22.0	14.0	264 011	1
PG 13.5	18	19.15	80.0	22.0	16.0	264 135	1
PG 16	18	21.25	80.0	22.0	18.0	264 016	1
PG 21	16	26.95	90.0	22.0	22.0	264 021	1
PG 29	16	35.60	100.0	25.0	28.0	264 029	1
PG 36	16	45.60	140.0	40.0	36.0	264 036	1
PG 42	16	52.60	140.0	40.0	40.0	264 042	1
PG 48	16	57.90	160.0	40.0	45.0	264 048	1

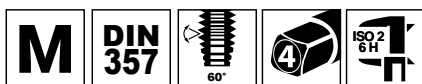

## Muttergewindebohrer, metrisch, DIN 357 zur Aufnahme mehrerer geschnittener Muttern – lang



Anschnitt: ca. 2/3 der Gewindelänge  
 Gewinde: metrisch DIN ISO 13  
 Flanken: hinterschliffen

Verpackung: Kunststoff

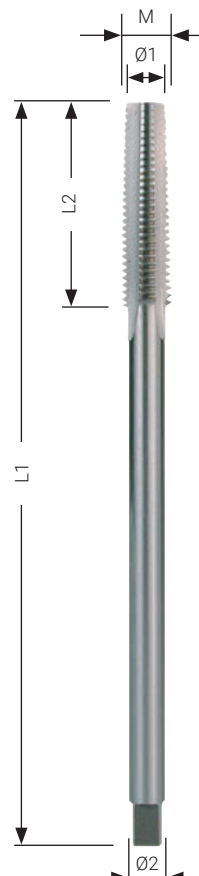

Nennmaß M	Steigung mm	Kernloch Ø1 mm	L1 mm	L2 mm	Ø2 mm	HSS	
M 3	0.50	2.5	70.0	22.0	2.2	243 030	1
M 4	0.70	3.3	90.0	25.0	2.8	243 040	1
M 5	0.80	4.2	100.0	28.0	3.5	243 050	1
M 6	1.00	5.0	110.0	32.0	4.5	243 060	1
M 8	1.25	6.8	125.0	40.0	6.0	243 080	1
M 10	1.50	8.5	140.0	45.0	7.0	243 100	1
M 12	1.75	10.2	180.0	50.0	9.0	243 120	1
M 14	2.00	12.0	200.0	56.0	11.0	243 140	1
M 16	2.00	14.0	200.0	63.0	12.0	243 160	1
M 18	2.50	15.5	220.0	63.0	14.0	243 180	1
M 20	2.50	17.5	250.0	70.0	16.0	243 200	1
M 22	2.50	19.5	280.0	80.0	18.0	243 220	1
M 24	3.00	21.0	280.0	80.0	18.0	243 240	1

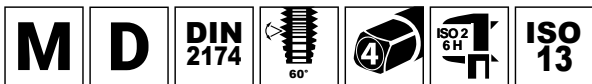

## Gewindeformer DIN 2174 mit verstärktem Schaft für Durchgangsgewinde und Sacklochgewinde

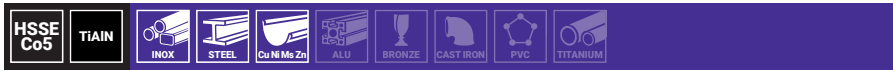

Gewindeformer aus kobaltlegiertem Schnellarbeitsstahl mit Titan-Aluminium-Nitrid-Beschichtung. Geeignet für unlegierte und legierte Stähle über 1000 N/mm<sup>2</sup> Festigkeit, hochchromlegierte Stähle wie V2A und NE-Metalle.

Anschnitt: Form D - ca. 4 - 6 Gänge  
 Gewinde: metrisch DIN ISO 13  
 Flanken: hinterschliften

Verpackung: Kunststoff



06

Gewinde Nennmaß M	Steigung mm	Kernloch Ø1 mm	L1 mm	L2 mm	Schaft-Ø2 mm	HSSE-Co 5 TiAlN	
M 3	0,50	2,80	56,0	11,0	3,5	271 003 F	1
M 4	0,70	3,70	63,0	13,0	4,5	271 004 F	1
M 5	0,80	4,65	70,0	16,0	6,0	271 005 F	1
M 6	1,00	5,55	80,0	19,0	6,0	271 006 F	1
M 8	1,25	7,45	90,0	22,0	8,0	271 008 F	1
M 10	1,50	9,35	100,0	24,0	10,0	271 010 F	1
M 12	1,75	11,20	110,0	28,0	9,0	271 012 F	1

i

### Unterschied zwischen Gewindeschneiden und Gewindeformen

Der Unterschied liegt darin, dass beim Gewindeformen durch spanloses Formen keine Unterbrechung des Faserverlaufs im Material verursacht wird. Durch die Verformung entstehen sehr steife Gewindegänge. Gleichbleibende Genauigkeit wird auch bei hoher Produktivität gewährleistet.

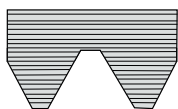

Gewindeschneiden

Faserverlauf beim Gewindeschneiden

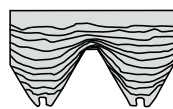

Gewindeformen

Faserverlauf beim Gewindeformen

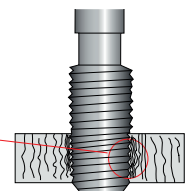



## Kombi-Maschinengewindebohrer-Bit für Kernloch- und Durchgangsgewinde – lang

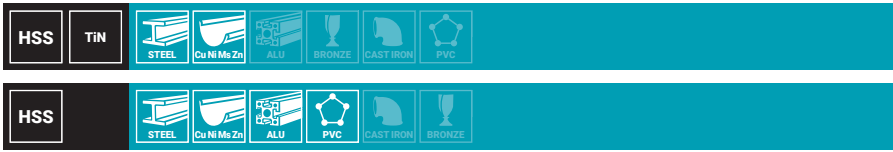

Der Kombi-Gewindebohrer eignet sich ideal für die Blechbearbeitung mit Rechts-/Linkslauf in Akkubohrmaschinen. Das Gewinde wird in einem Arbeitsgang geschnitten, ohne Werkzeugwechsel. Ein Spiralbohrer ist dem Gewinde vorgesetzt.

Flanken: hinterschliffen  
 Schaft: 1/4" x 27,0 mm  
 Max. Materialstärke: 1 x M (z. B. M 10 = 10 mm Materialstärke)

Verpackung: Kunststoff

Gewinde Nennmaß M	Steigung mm	L1 mm	Ø1 mm	HSS TiN	HSS	
M 3	0.50	51.0	2.5	270 014 T	270 014	1
M 4	0.70	54.0	3.3	270 015 T	270 015	1
M 5	0.80	57.0	4.2	270 016 T	270 016	1
M 6	1.00	60.0	5.0	270 017 T	270 017	1
M 8	1.25	68.0	6.8	270 018 T	270 018	1
M 10	1.50	75.0	8.5	270 019 T	270 019	1

		HSS TiN	HSS
<b>7</b> tlg./pcs.	Kombi-Maschinengewindebohrer- Bit Satz – lang  6 Kombi-Maschinengewindebohrer M 3   M 4   M 5   M 6   M 8   M 10 + 1 Sechskantmagnethalter	270 020 TRO	270 020 RO



## Magnethalter mit 1/4" Sechskantaufnahme

Verpackung: Kunststoff

Sechskantmagnethalter	270 013	1





## Kombi-Maschinengewindebohrer-Bit für Kernloch- und Durchgangsgewinde – kurz

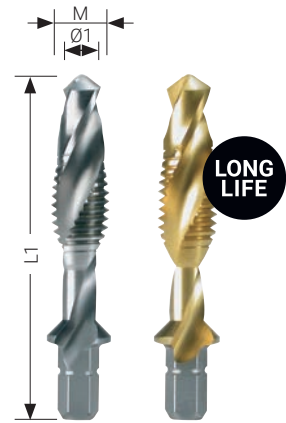
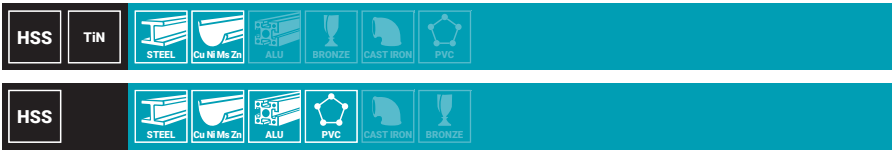

Der Kombi-Gewindebohrer eignet sich ideal für die Blechbearbeitung mit Rechts-/Linkslauf in Akkubohrmaschinen. Das Gewinde wird in einem Arbeitsgang geschritten, ohne Werkzeugwechsel. Ein Spiralbohrer ist dem Gewinde vorgesetzt.

Flanken: hinterschliften  
 Schaft: 1/4" x 27,0 mm  
 Max. Materialstärke: 1 x M (z. B. M 10 = 10 mm Materialstärke)

Verpackung: Kunststoff

06

Gewinde Nennmaß M	Steigung mm	L1 mm	Ø1 mm	HSS TiN		HSS	
M 3	0.50	36.0	2.5	R 270 014 T	R 270 014	1	
M 4	0.70	39.0	3.3	R 270 015 T	R 270 015	1	
M 5	0.80	41.0	4.2	R 270 016 T	R 270 016	1	
M 6	1.00	44.0	5.0	R 270 017 T	R 270 017	1	
M 8	1.25	51.0	6.8	R 270 018 T	R 270 018	1	
M 10	1.50	59.0	8.5	R 270 019 T	R 270 019	1	

		HSS TiN	HSS
<b>7</b> tlg./pcs.	Kombi-Maschinengewindebohrer- Bit Satz – kurz  6 Kombi-Maschinengewindebohrer M 3   M 4   M 5   M 6   M 8   M 10 + 1 Sechskantmagnethalter	R 270 021 TRO	R 270 020 RO



R 270 020 RO



### Anwendungstipp

#### In einem Arbeitsgang

- ✓ Kernlochbohren mit Spiralbohrer
- ✓ Gewinde schneiden
- ✓ Gewinde entgraten
- ✓ Gewinde säubern (beim Rücklauf)

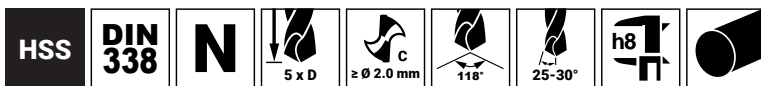

## 1 Spiralbohrer DIN 338 Typ N

geschliffene Ausführung, passgenau auf die Bohrbuchsen abgestimmt

Verpackung: Kunststoff

Ø mm	Ø Zoll	für Stiftgröße	L1 mm	HSS	
3.2	1/8"	1 - 4	65.0	214 032	1
4.8	3/16"	5 - 7	86.0	214 048	1
6.4	1/4"	8	101.0	214 064	1
8.0	5/16"	9	117.0	214 080	1
8.7	11/32"	10	125.0	214 087	1

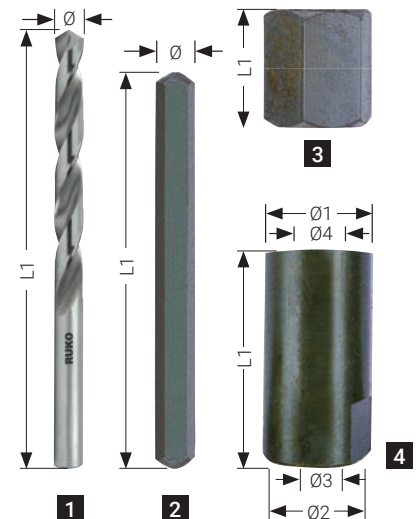

## 2 Ausdrehstift

aus Spezial-Profilstahl, gehärtet, brüniert

Größe	Gewinde Nennmaß M	Ø mm	Ø Zoll	L1 mm		
1	M 5 - M 6	3.2	1/8"	60.0	244 001	1
2	M 7 - M 8	4.8	3/16"	70.0	244 002	1
3	M 9 - M 10	6.4	1/4"	78.0	244 003	1
4	M 12	8.0	5/16"	83.0	244 004	1
5	M 14 - M 16	8.7	11/32"	94.0	244 005	1

## 3 Ausdrehmutter

mit Spezial-Innenprofil, gehärtet, brüniert

Größe	für Stiftgröße	SW mm	L1 mm		
1	1	10.0	16.0	244 032	1
2	2	11.0	16.0	244 046	1
3	3	13.0	16.0	244 064	1
4	4	14.0	16.0	244 080	1
5	5	17.0	16.0	244 087	1

## 4 Bohrbuchse

abgesetzt, gehärtet, brüniert, für tieferliegende Schraubenreste (Ø 1 + Ø 2), für hervorstehende Schraubenreste (Ø 4)

Größe	Ø 1 mm	Ø 2 mm	Ø 3 mm	Ø 4 mm	Ø 3 Zoll	Ø 4 Zoll	SW mm	L1 mm		
1	7.0	6.0	3.2	5.0	1/8"	3/16"	6.0	30.0	244 101	1
2	8.0	7.0	3.2	6.0	1/8"	—	7.0	30.0	244 102	1
3	9.0	—	3.2	7.0	1/8"	1/4"	8.0	30.0	244 103	1
4	10.0	—	3.2	8.0	1/8"	5/16"	9.0	30.0	244 104	1
5	11.0	—	4.8	8.0	3/16"	5/16"	9.0	30.0	244 105	1
6	12.0	—	4.8	9.0	3/16"	—	10.0	30.0	244 106	1
7	13.0	—	4.8	10.0	3/16"	1/8"	11.0	30.0	244 107	1
8	14.0	—	6.4	11.0	1/4"	7/16"	12.0	30.0	244 108	1
9	15.0	—	8.0	12.0	5/16"	—	13.0	30.0	244 109	1
10	17.0	16.0	8.7	14.0	11/32"	—	14.0	30.0	244 110	1

## Gewindeausdreh-Satz

<b>25</b> Stk./Pcs.	Gewindeausdreh-Satz 5 Spiralbohrer, 5 Ausdrehstifte, 5 Ausdrehmutter und 10 Bohrbuchsen	244 151



07

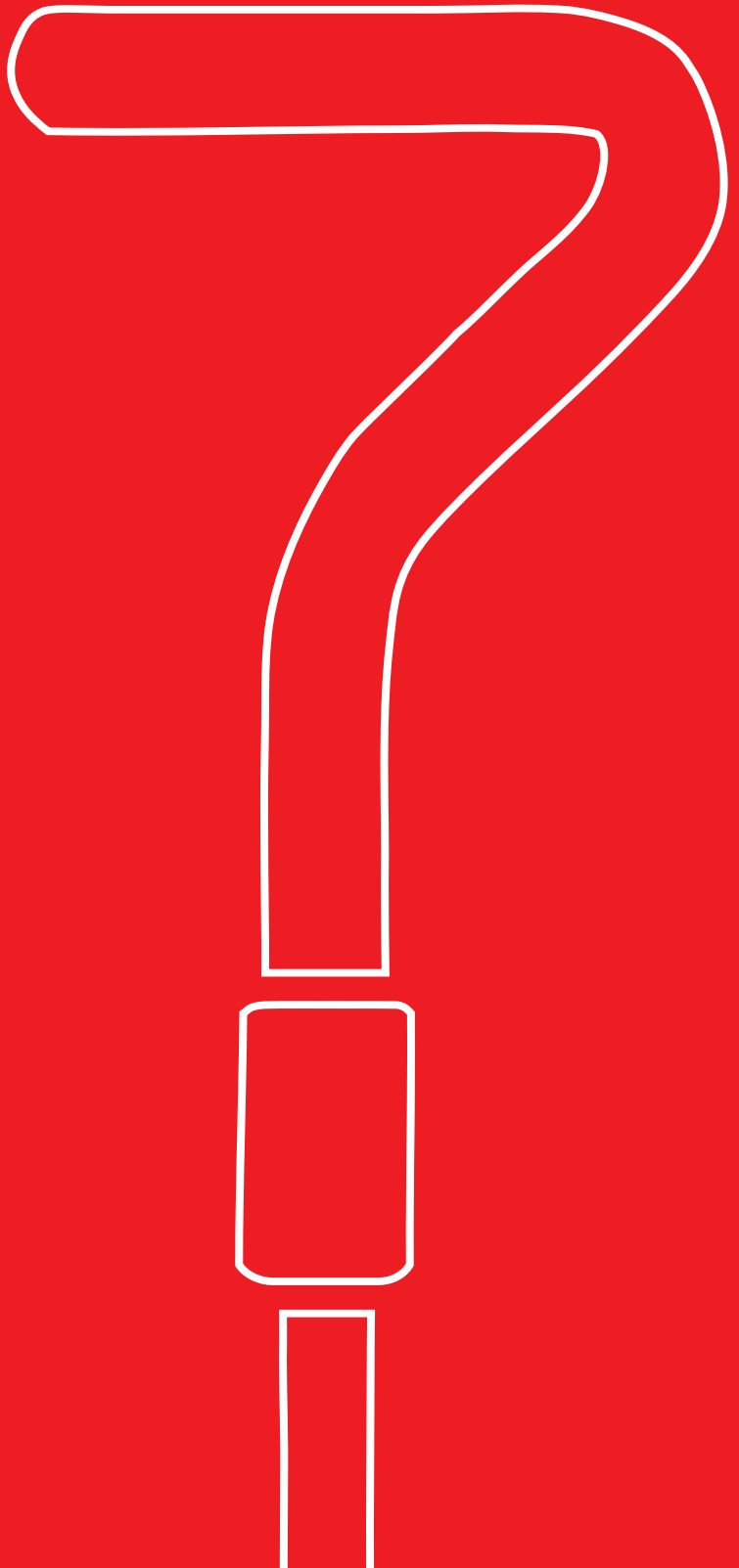

# GEWINDEREPARATUR- WERKZEUGE

Gewindeeinsätze	182
Zapfenbrecher	182
Einbauwerkzeug	182
ProCoil Gewindereparatur-Sortimente	183
ProCoil Gewindereparatur-Sätze	184
Zubehör: Spiralbohrer DIN 338 Typ N HSS-G + Einschnittgewindebohrer HSS für ProCoil	185

# Gewindeinsätze

Standardausführung, aus rostfreiem Stahl, frei durchlaufend.

Zur Gewindepanzerung von Werkstoffen geringer Scherfestigkeit, z. B. Aluminium- oder Magnesium-Legierungen sowie zur Gewindereparatur abgenutzter oder beschädigter Gewinde.

Verpackung: Kunststoff



Gewinde Nennmaß	Steigung mm	Höhe = Faktor x Ø		
M 3	0.50	1.0	244 303	50
M 4	0.70	1.0	244 304	50
M 5	0.80	1.0	244 305	50
M 6	1.00	1.0	244 306	50
M 8	1.25	1.0	244 308	50
M 10	1.50	1.0	244 310	50
M 12	1.75	1.0	244 312	25
M 14	2.00	1.0	244 314	25
MF 14	1.25	1.0	244 315	25

M 3	0.50	1.5	244 403	50
M 4	0.70	1.5	244 404	50
M 5	0.80	1.5	244 405	50
M 6	1.00	1.5	244 406	50
M 8	1.25	1.5	244 408	50
M 10	1.50	1.5	244 410	50
M 12	1.75	1.5	244 412	25
M 14	2.00	1.5	244 414	25
MF 14	1.25	1.5	244 415	25

M 3	0.50	2.0	244 503	50
M 4	0.70	2.0	244 504	50
M 5	0.80	2.0	244 505	50
M 6	1.00	2.0	244 506	50
M 8	1.25	2.0	244 508	50
M 10	1.50	2.0	244 510	50
M 12	1.75	2.0	244 512	25
M 14	2.00	2.0	244 514	25
MF 14	1.25	2.0	244 515	25

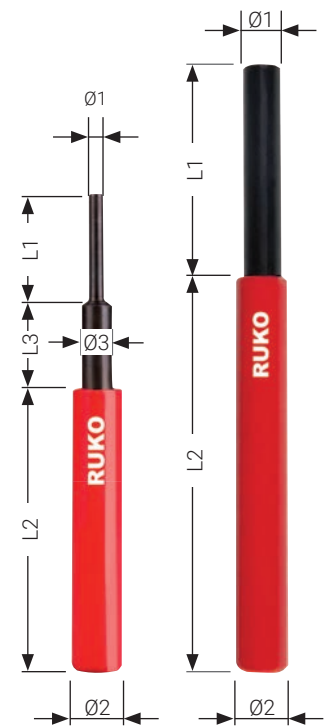

# Zapfenbrecher

Gewinde Nennmaß	Ø1 mm	Ø2 mm	Ø3 mm	L1 mm	L2 mm	L3 mm		
M 3	2.0	9.8	6.0	15.0	75.0	25.0	244 163	1
M 4	2.7	9.8	6.0	20.0	75.0	20.0	244 164	1
M 5	3.5	9.8	-	22.0	75.0	18.0	244 165	1
M 6	4.6	9.8	-	22.0	75.0	18.0	244 166	1
M 8	6.0	9.8	-	40.0	75.0	-	244 168	1
M 10	7.5	9.8	-	40.0	75.0	-	244 170	1
M 12	9.0	12.2	-	40.0	75.0	-	244 172	1
M 14	10.0	14.5	-	40.0	80.0	-	244 174	1

# Einbauwerkzeug

Gewinde Nennmaß	Ø mm	L1 mm		
M 3	2.0	60.0	244 183	1
M 4	2.8	60.0	244 184	1
M 5	3.5	60.0	244 185	1
M 6	4.8	60.0	244 186	1
M 8	6.0	80.0	244 188	1
M 10	7.5	80.0	244 190	1
M 12	9.5	80.0	244 192	1
M 14	11.2	80.0	244 194	1



7  
07



## ProCoil Gewindereparatur-Sortimente



Bild zeigt ProCoil Gewindereparatur-Satz 86-teilig (244 208).  
Weitere Ausführung siehe Tabelle.





		
<b>86</b> <small>Stk./Pcs.</small>	<p>Sortiment M 5 - M 12</p> <p>5 Spiralbohrer HSS Ø 5.2   6.2   8.3   10.3   12.4 mm                      + 5 Einschnittgewindebohrer DIN 352 HSS - M 5   M 6   M 8   M 10   M 12                      + 5 Einbauwerkzeuge M 5   M 6   M 8   M 10   M 12                      + 5 Zapfenbrecher Ø 3.5 - 4.6 - 6.0 - 7.5 - 9.0 mm                      + 60 Gewindeeinsätze M 5 - M 10 - je 5 x Ø 1.0 / 1.5 / 2.0: Höhe = 1.0 x Ø                      + 6 Gewindeeinsätze M 12 - je 2 x Ø 1.0 / 1.5 / 2.0: Höhe = 1.0 x Ø</p>	244 208
<b>77</b> <small>Stk./Pcs.</small>	<p>Sortiment M 6 - M 14 für Zündkerzengewinde</p> <p>5 Spiralbohrer HSS Ø 6.2   8.3   10.3   12.4   14.5 mm                      + 5 Einschnittgewindebohrer DIN 352 HSS - M 6   M 8   M 10   M 12   MF 14                      + 5 Einbauwerkzeuge M 6   M 8   M 10   M 12   MF 14                      + 5 Zapfenbrecher Ø 4.6   6.0   7.5   9.0   10.0 mm                      + 45 Gewindeeinsätze M 6 - M 10 - je 5 x Ø 1.0 / 1.5 / 2.0: Höhe = 1.0 x Ø                      + 12 Gewindeeinsätze M 12 - MF 14 - je 2 x Ø 1.0 / 1.5 / 2.0: Höhe = 1.0 x Ø</p>	244 209



## ProCoil Gewindereparatur-Sätze



Bild zeigt Gewindereparatur-Satz 19-teilig (244 206).  
Weitere Ausführungen siehe Tabelle.

	Satz M 3	1 Spiralbohrer Ø 3.1 mm + 1 Einschnittgewindebohrer DIN 352 HSS für Gewinde M 3 x 0.5 + 1 Einbauwerkzeug M 3 + 1 Zapfenbrecher Ø 2.0 mm + je 5 Gewindeeinsätze Höhe = 1.0 x Ø / Höhe = 1.5 x Ø / Höhe = 2.0 x Ø	244 200
	Satz M 4	1 Spiralbohrer Ø 4.1 mm + 1 Einschnittgewindebohrer DIN 352 HSS für Gewinde M 4 x 0.7 + 1 Einbauwerkzeug M 4 + 1 Zapfenbrecher Ø 2.7 mm + je 5 Gewindeeinsätze Höhe = 1.0 x Ø / Höhe = 1.5 x Ø / Höhe = 2.0 x Ø	244 201
	Satz M 5	1 Spiralbohrer Ø 5.2 mm + 1 Einschnittgewindebohrer DIN 352 HSS für Gewinde M 5 x 0.8 + 1 Einbauwerkzeug M 5 + 1 Zapfenbrecher Ø 3.5 mm + je 5 Gewindeeinsätze Höhe = 1.0 x Ø / Höhe = 1.5 x Ø / Höhe = 2.0 x Ø	244 202
	Satz M 6	1 Spiralbohrer Ø 6.2 mm + 1 Einschnittgewindebohrer DIN 352 HSS für Gewinde M 6 x 1.0 + 1 Einbauwerkzeug M 6 + 1 Zapfenbrecher Ø 4.6 mm + je 5 Gewindeeinsätze Höhe = 1.0 x Ø / Höhe = 1.5 x Ø / Höhe = 2.0 x Ø	244 203
	Satz M 8	1 Spiralbohrer Ø 8.3 mm + 1 Einschnittgewindebohrer DIN 352 HSS für Gewinde M 8 x 1.25 + 1 Einbauwerkzeug M 8 + 1 Zapfenbrecher Ø 6.0 mm + je 5 Gewindeeinsätze Höhe = 1.0 x Ø / Höhe = 1.5 x Ø / Höhe = 2.0 x Ø	244 204
	Satz M 10	1 Spiralbohrer Ø 10.3 mm + 1 Einschnittgewindebohrer DIN 352 HSS für Gewinde M 10 x 1.5 + 1 Einbauwerkzeug M 10 + 1 Zapfenbrecher Ø 7.5 mm + je 5 Gewindeeinsätze Höhe = 1.0 x Ø / Höhe = 1.5 x Ø / Höhe = 2.0 x Ø	244 205
	Satz M 12	1 Spiralbohrer Ø 12.4 mm + 1 Einschnittgewindebohrer DIN 352 HSS für Gewinde M 12 x 1.75 + 1 Einbauwerkzeug M 12 + 1 Zapfenbrecher Ø 9.0 mm + je 5 Gewindeeinsätze Höhe = 1.0 x Ø / Höhe = 1.5 x Ø / Höhe = 2.0 x Ø	244 206
	Satz M 14	1 Spiralbohrer Ø 14.5 mm + 1 Einschnittgewindebohrer DIN 352 HSS für Gewinde M 14 x 2.0 + 1 Einbauwerkzeug M 14 + 1 Zapfenbrecher Ø 10.0 mm + je 5 Gewindeeinsätze Höhe = 1.0 x Ø / Höhe = 1.5 x Ø / Höhe = 2.0 x Ø	244 207



## Zubehör

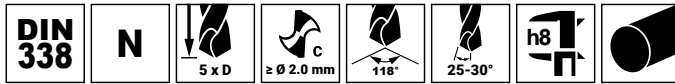

### Spiralbohrer DIN 338 Typ N HSS-G



Leistungsstarker, geschliffener Spiralbohrer aus Schnellarbeitsstahl. Der komplett geschliffene Spiralbohrer verfügt über eine erhöhte Rundlaufgenauigkeit. Einsatzgebiete: für Stahl, Stahlguss legiert und unlegiert (bis 900 N/mm<sup>2</sup> Festigkeit), Grau-, Temper-, Sphäro- und Druckguß, Sinterisen, Neusilber, Graphit, kurzspannende Aluminiumlegierungen, Messing und Bronze.

Verpackung: Kunststoff

Für Gewinde	Kernloch Ø1 mm	L1 mm	L2 mm	HSS	
M 3	3.10	65.0	36.0	214 031	10
M 4	4.10	75.0	43.0	214 041	10
M 5	5.20	86.0	52.0	214 052	10
M 6	6.20	101.0	63.0	214 062	10
M 8	8.30	117.0	75.0	214 083	10
M 10	10.30	133.0	87.0	214 103	10
M 12	12.40	151.0	101.0	214 124	5
M 14 + MF 14	14.50	169.0	114.0	214 145	5

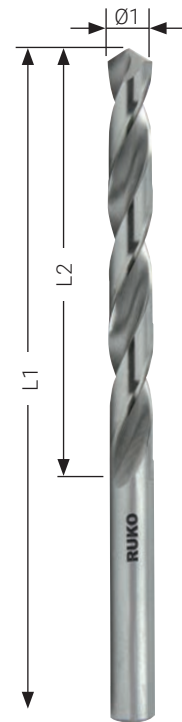

### Einschnittgewindebohrer HSS für ProCoil



Gewindebohrer HSS für Durchgangsgewinde, in unlegierte und niedriglegierte Stähle bis 800 N/mm<sup>2</sup> Festigkeit, Temperguss und NE-Metalle. Das Gewinde kann von Hand und im Maschinengebrauch in einem Arbeitsgang geschnitten werden.

Verpackung: Kunststoff

Für Gewinde	Kernloch Ø1 mm	M mm	L1 mm	L2 mm	HSS	
M 3	3.10	3.6	53.0	13.0	244 603	1
M 4	4.10	4.9	58.0	16.0	244 604	1
M 5	5.20	6.0	66.0	19.0	244 605	1
M 6	6.20	7.3	72.0	22.0	244 606	1
M 8	8.30	9.6	80.0	24.0	244 608	1
M 10	10.30	11.9	89.0	29.0	244 610	1
M 12	12.40	14.3	95.0	30.0	244 612	1
M 14	14.50	16.6	102.0	32.0	244 614	1
MF 14	14.50	15.6	102.0	32.0	244 615	1

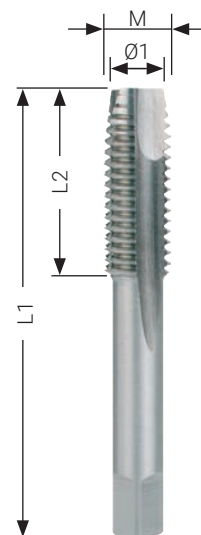

08











































# KERNBOHRTECHNIK

## KERNBOHRER

Typen- und Anwendungsübersicht	188 – 189
Technische Daten	190
Weiterentwicklung der Schneidengeometrie	191
Kleineres Zerspanvolumen – Deswegen sind Kernbohrer bei großen Bohrdurchmessern die bessere Alternative	191
Vollbohrer "Solid 3S" HSS mit Weldonschaft und 3 Schneiden, Schnitttiefe 30.0 mm	192
Kernbohrer HSS und HSSE-Co 5 mit Weldonschaft, Schnitttiefe 55.0 mm	193
Kernbohrer HSSE-Co 5 / HSS mit Weldonschaft, Schnitttiefe 30.0 mm	194 – 195
Kernbohrer HSS mit Weldonschaft Schnitttiefe 110.0 mm – extra lang	196
Kernbohrer HSSE-Co 5 mit Quick IN-Schaft, Schnitttiefe 35.0 mm	197
Kernbohrer mit Hartmetallschneiden und Weldonschaft, Schnitttiefe 50.0 mm	198
Kernbohrer mit Hartmetallschneiden und Quick IN-Schaft, Schnitttiefe 50.0 mm	199
Kernbohrer mit Hartmetallschneiden, Innengewinde, inklusive Adapter mit Quick IN-Schaft, Schnitttiefe 50.0 mm	200
Kernbohrer mit Hartmetallschneiden und Gewindeaufnahme, Schnitttiefe 50.0 mm	201
Kernbohrer mit Hartmetallschneiden und Weldonschaft für Eisenbahnschienen, Schnitttiefe 30.0 mm	202
Auswerferstifte für Kernbohrer HSS + HM	203
Drehzahlrichtwerte für Kernbohrer HSS	204
Drehzahlrichtwerte für Kernbohrer mit Hartmetallschneiden	205

# Typen- und Anwendungsübersicht

	Werkstoff	Oberfläche	Bohrtiefe	Schaft	Auswerferstift	RUKO Magnetbohrmaschine	Ø mm	Art.-Nr.	Seite/n
	HSS	Blank	 30 mm		-	A10 RU25 RU40	10,0 – 15,0	108 121x	192
	HSS	Blank	 55 mm		108 305		12,0 – 60,0	108 51xx	193
	HSSE Co5	Blank	 55 mm					108 5xx E	
	HSS	TiAlN	 55 mm					108 5xx F	
	HSS	Blank	 30 mm					108 304	
	HSSE Co5	Blank	 30 mm		108 2xx E				
	HSS	TiAlN	 30 mm		108 2xx F				
	HSS	Blank	 110 mm		108 2000		20,0 – 32,0	108 20xx	196
	HSS	TiAlN	 110 mm					108 20xx F	
	HSSE Co5	Blank	 55 mm		108 306		12,0 – 60,0	108 9xx E	197
	TC HM	Blank	 50 mm		108 305		12,0 – 50,0	108 7xx	198
	TC HM	Blank	 50 mm		108 305		12,0 – 32,0	108 11xx	199
	TC HM	Blank	 50 mm		108 305		33,0 – 80,0	108 11xx	200
	TC HM	Blank	 50 mm		108 110		12,0 – 80,0	108 0xx	201
	TC HM	Blank	 30 mm		108 1510	19,0 – 36,0	108 15xx	202	

Baustahl < 900 N/mm <sup>2</sup>	Inox < 1100 N/mm <sup>2</sup>	Hochfester Stahl < 1300 N/mm <sup>2</sup>	Messing	Bronze	Guss	Aluminium	Kunststoffe
●			●	○	○	●	○
●			●	○	○	●	○
●	●	○	●	○	○	●	○
●	●	○	●	○	○	●	○
●			●	○	○	●	○
●	●	○	●	○	○	●	○
●	●	○	●	○	○	●	○
●			●	○	○	●	○
●	●	○	●	○	○	●	○
●	●	○	●	○	○	●	○
●	●	●	●	●	○	●	○
●	●	●	●	●	○	●	○
●	●	●	●	●	○	●	○
●	●	●	●	●		●	○
●	●	●	●	●	○	●	○





### Vollbohrer mit Weldonschaft (3/4")

Einsetzbar in allen Säulen- und Magnetbohrmaschinen mit Morsekonus in Verbindung mit RUKO Aufnahmehalter Nr. 108 302-1, 108 303-1, 108 315, 108 316, der RUKO EasyLock Nr. 108 312-1, 108 313-1, 108 314 oder mit Weldonschaftdirektaufnahme wie z. B. RUKO Magnetbohrmaschine A10.

#### Handhabung bei Vollbohrern mit Weldonschaft

- Vollbohrer in den Aufnahmehalter schieben und die Innensechskantschrauben fest anziehen.
- Auf sauberen Sitz des Vollbohrers „Solid 3S“ im Aufnahmehalter achten.
- Bei der EasyLock Schnellspannaufnahme wird der Vollbohrer automatisch arretiert.
- Sofort auf Maß bohren, Ankörnen und Vorbohren entfallen.
- Die Schneidengeometrie des Vollbohrers ermöglicht eine schnelle Spanabfuhr nach oben.
- Drehzahltable beachten und Kühlmittel verwenden.



### Kernbohrer mit Weldonschaft (3/4")

Einsetzbar in allen Säulen- und Magnetbohrmaschinen mit Morsekonus in Verbindung mit RUKO Aufnahmehalter Nr. 108 302-1, 108 303-1, 108 315, 108 316, der RUKO EasyLock Nr. 108 312-1, 108 313-1, 108 314 oder mit Weldonschaftdirektaufnahme wie z. B. RUKO Magnetbohrmaschine A10.

#### Handhabung bei Kernbohrern mit Weldonschaft

- Auswerferstift in den Kernbohrer einstecken.
- Kernbohrer in den Aufnahmehalter schieben und die Innensechskantschrauben fest anziehen.
- Auf sauberen Sitz des Kernbohrers im Aufnahmehalter achten.
- Bei der EasyLock Schnellspannaufnahme wird der Kernbohrer automatisch arretiert.
- Sofort auf Maß bohren, Ankörnen und Vorbohren entfallen.
- Die Schneidengeometrie des Kernbohrers ermöglicht eine schnelle Spanabfuhr nach oben.
- Der federnd gelagerte Auswerferstift hilft die ausgeschnittenen Stücke zu lösen.
- Drehzahltable beachten und Kühlmittel verwenden.



### Kernbohrer mit Quick IN-Schaft

Einsetzbar in allen Säulen- und Magnetbohrmaschinen in Verbindung mit Aufnahmehalter Quick IN-System wie z. B. Fein KBM 32 Q.

#### Handhabung bei Kernbohrern mit Quick IN-Schaft

- Auswerferstift in den Kernbohrer einstecken.
- Kernbohrer in den Quick IN- Aufnahmehalter spannen.
- Sofort auf Maß bohren, Ankörnen und Vorbohren entfallen.
- Die Schneidengeometrie des Kernbohrers ermöglicht eine schnelle Spanabfuhr nach oben.
- Der federnd gelagerte Auswerferstift hilft die ausgeschnittenen Stücke zu lösen.
- Drehzahltable beachten und Kühlmittel verwenden.



### Kernbohrer mit Gewindeaufnahme

Einsetzbar in allen Säulen- und Magnetbohrmaschinen mit Morsekonus in Verbindung mit RUKO Aufnahmehalter Nr. 108 102-1, 108 103-1, 108 104, 108 105 oder mit Gewindedirektaufnahme wie z. B. Fein KBM 542 / KBM 65.

#### Handhabung bei Kernbohrern mit Gewindeaufnahme

- Kernbohrer auf Aufnahmehalter aufschrauben.
- Sofort auf Maß bohren, Ankörnen und Vorbohren entfallen.
- Die Schneidengeometrie des Kernbohrers ermöglicht eine schnelle Spanabfuhr nach oben.
- Der federnd gelagerte Auswerferstift hilft die ausgeschnittenen Stücke zu lösen.
- Drehzahltable beachten und Kühlmittel verwenden.



## Weiterentwicklung der Schneidengeometrie

Durch eine weiterentwickelte Schneidengeometrie konnte ein deutlich verbessertes Schneidverhalten erreicht werden, welches sich positiv auf die Schneidleistung und Standzeit auswirkt.

1. Optimierte Schneidengeometrie für erhöhte Zerspanleistung und verringerte Schnittkräfte.
2. Die Spanwinkel sind für den universellen Einsatz in verschiedenen Stahlsorten ausgelegt.
3. Verbesserte Spanabfuhr durch U-förmige Auslückung. Die spezielle Geometrie der Auslückung verringert die thermische Belastung des HSS-Kernbohrers, da die Wärme, welche bei der Zerspanung entsteht, weitestgehend mit dem Span abgeführt wird.
4. Reduktion der Reibung zwischen dem HSS-Kernbohrer und dem Werkstück durch optimierte, spiralförmig verlaufende Führungsfasen.

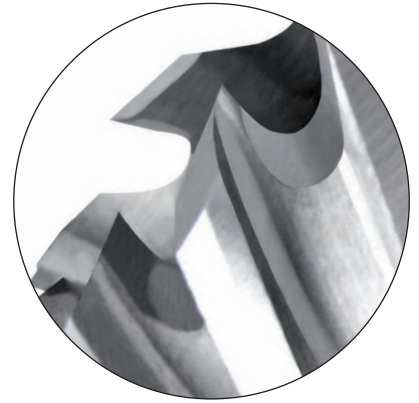

## Kleineres Zerspanvolumen – Deswegen sind Kernbohrer bei großen Bohrdurchmessern die bessere Alternative

RUKO Kernbohrer sparen enorme Kosten und Zeit, da sie nur einen Ring zerspanen und nicht den kompletten Bohrdurchmesser. Dadurch sind sie bei großen Bohrdurchmessern um ein Vielfaches schneller (s. Grafik). Das Zentrieren, Vor- und Aufbohren entfällt.

Kernbohrer zerspanen, anders als der Spiralbohrer, nur die Zahnbreite und der Bohrkern wird ausgeworfen:



Zerspanvolumen  
Kernbohrer



Zerspanvolumen  
Spiralbohrer

Neben dem geringeren Energiebedarf arbeiten die Kernbohrer mit geringerem Verschleiß und einer daraus resultierenden höheren Standzeit.



### Bohrzeitenvergleich

#### Kernbohrer HSS - Spiralbohrer HSS DIN 345

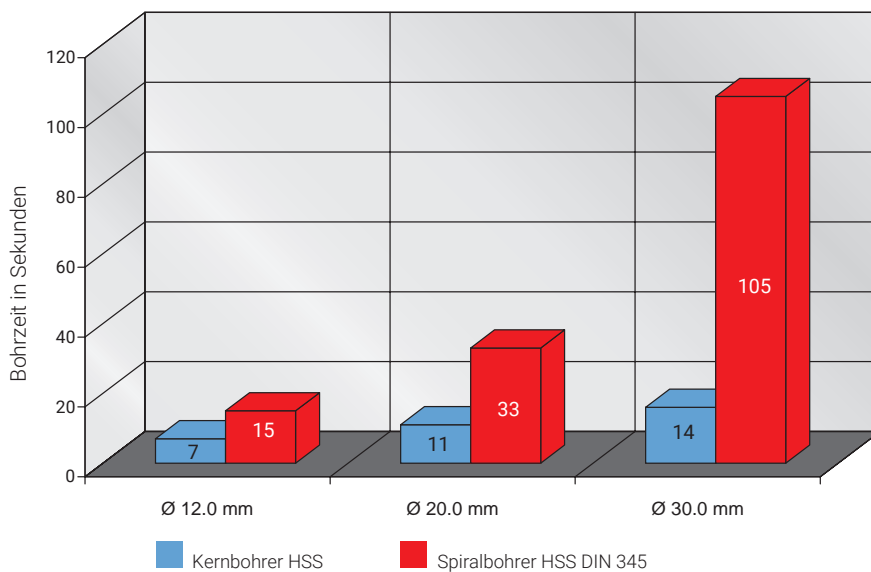

Werkstück: Stahlträger  
Material: allgemeiner Baustahl S235JR - gemäß DIN EN 10025  
Bohrtiefe: 12.0 mm

Maschine: RUKO Magnetbohrmaschine. Mit den Spiralbohrern wurde ohne vorzubohren ins volle Material gebohrt. Es wurde weder gekühlt noch geschmiert.



## Vollbohrer "Solid 3S" HSS mit Weldonschaft und 3 Schneiden, Schnitttiefe 30.0 mm



Die spiralgenutete 3-Schneidengeometrie sorgt für eine extrem hohe Stabilität des Vollbohrers „Solid 3S“ und verhindert dadurch die Bruchgefahr der Schneiden durch Überbeanspruchung oder Verkleben der Späne. Durch die hohe Stabilität wird die Standzeit des „Solid 3S“ deutlich erhöht. Dies reduziert die Einsatzkosten. Der „Solid 3S“ ermöglicht punktgenaues Anbohren ohne Ankörnen und Anreißen. Der Vollbohrer lässt sich einfacher Nachschleifen als Kernbohrer gleichen Durchmessers.



Verpackung: Kunststoff

Ø1 mm	Ø2 mm	L1 mm	Schnitttiefe mm	HSS	
10.0	19.0	64.0	30.0	108 1210	1
11.0	19.0	64.0	30.0	108 1211	1
12.0	19.0	64.0	30.0	108 1212	1
13.0	19.0	64.0	30.0	108 1213	1
14.0	19.0	64.0	30.0	108 1214	1
15.0	19.0	64.0	30.0	108 1215	1

08

	HSS
6 tlg.-pcs. Vollbohrer-Satz „Solid 3S“ HSS Ø 10.0   11.0   12.0   13.0   14.0   15.0 mm	108 830



### Anwendungstipp

Die Bruchgefahr des Vollbohrers bis Ø 15.0 mm ist deutlich geringer gegenüber Kernbohrern gleichen Durchmessers. Kühlung erforderlich.



## Kernbohrer HSS und HSSE-Co 5 mit Weldonschaft, Schnitttiefe 55.0 mm



Auswerferstift: Art.-Nr. 108 305 (Ø 6,35 x 102,0 mm)

Verpackung: Kunststoff

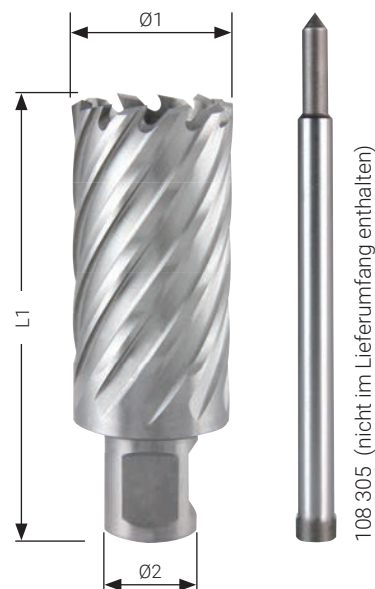

Ø1 mm	Ø2 mm	L1 mm	Schnitttiefe mm	HSSE-Co 5	HSS TiAIN	HSS	
12.0	19.0	88.0	55.0	108 512 E	108 512 F	108 512	1
13.0	19.0	88.0	55.0	108 513 E	108 513 F	108 513	1
14.0	19.0	88.0	55.0	108 514 E	108 514 F	108 514	1
15.0	19.0	88.0	55.0	108 515 E	108 515 F	108 515	1
16.0	19.0	88.0	55.0	108 516 E	108 516 F	108 516	1
17.0	19.0	88.0	55.0	108 517 E	108 517 F	108 517	1
18.0	19.0	88.0	55.0	108 518 E	108 518 F	108 518	1
19.0	19.0	88.0	55.0	108 519 E	108 519 F	108 519	1
20.0	19.0	88.0	55.0	108 520 E	108 520 F	108 520	1
21.0	19.0	88.0	55.0	108 521 E	108 521 F	108 521	1
22.0	19.0	88.0	55.0	108 522 E	108 522 F	108 522	1
23.0	19.0	88.0	55.0	108 523 E	108 523 F	108 523	1
24.0	19.0	88.0	55.0	108 524 E	108 524 F	108 524	1
25.0	19.0	88.0	55.0	108 525 E	108 525 F	108 525	1
26.0	19.0	88.0	55.0	108 526 E	108 526 F	108 526	1
27.0	19.0	88.0	55.0	108 527 E	108 527 F	108 527	1
28.0	19.0	88.0	55.0	108 528 E	108 528 F	108 528	1
29.0	19.0	88.0	55.0	108 529 E	108 529 F	108 529	1
30.0	19.0	88.0	55.0	108 555 E	108 555 F	108 555	1
31.0	19.0	88.0	55.0	108 531 E	108 531 F	108 531	1
32.0	19.0	88.0	55.0	108 532 E	108 532 F	108 532	1
33.0	19.0	88.0	55.0	108 533 E	108 533 F	108 533	1
34.0	19.0	88.0	55.0	108 534 E	108 534 F	108 534	1
35.0	19.0	88.0	55.0	108 535 E	108 535 F	108 535	1
36.0	19.0	88.0	55.0	108 536 E	108 536 F	108 536	1
37.0	19.0	88.0	55.0	108 537 E	108 537 F	108 537	1
38.0	19.0	88.0	55.0	108 538 E	108 538 F	108 538	1
39.0	19.0	88.0	55.0	108 539 E	108 539 F	108 539	1
40.0	19.0	88.0	55.0	108 540 E	108 540 F	108 540	1
41.0	19.0	88.0	55.0	108 541 E	108 541 F	108 541	1
42.0	19.0	88.0	55.0	108 542 E	108 542 F	108 542	1
43.0	19.0	88.0	55.0	108 543 E	108 543 F	108 543	1
44.0	19.0	88.0	55.0	108 544 E	108 544 F	108 544	1
45.0	19.0	88.0	55.0	108 545 E	108 545 F	108 545	1
46.0	19.0	88.0	55.0	108 546 E	108 546 F	108 546	1
47.0	19.0	88.0	55.0	108 547 E	108 547 F	108 547	1
48.0	19.0	88.0	55.0	108 548 E	108 548 F	108 548	1
49.0	19.0	88.0	55.0	108 549 E	108 549 F	108 549	1
50.0	19.0	88.0	55.0	108 550 E	108 550 F	108 550	1
51.0	19.0	88.0	55.0	108 551 E	108 551 F	108 551	1
52.0	19.0	88.0	55.0	108 552 E	108 552 F	108 552	1
53.0	19.0	88.0	55.0	108 553 E	108 553 F	108 553	1
54.0	19.0	88.0	55.0	108 554 E	108 554 F	108 554	1
55.0	19.0	88.0	55.0	108 555 E	108 555 F	108 555	1
56.0	19.0	88.0	55.0	108 556 E	108 556 F	108 556	1
57.0	19.0	88.0	55.0	108 557 E	108 557 F	108 557	1
58.0	19.0	88.0	55.0	108 558 E	108 558 F	108 558	1
59.0	19.0	88.0	55.0	108 559 E	108 559 F	108 559	1
60.0	19.0	88.0	55.0	108 560 E	108 560 F	108 560	1





## Kernbohrer HSSE-Co 5 / HSS mit Weldonschaft, Schnitttiefe 30.0 mm

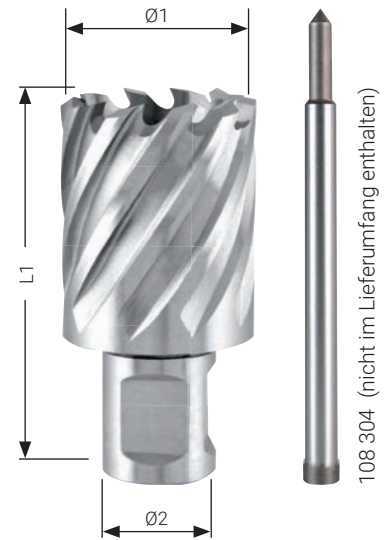
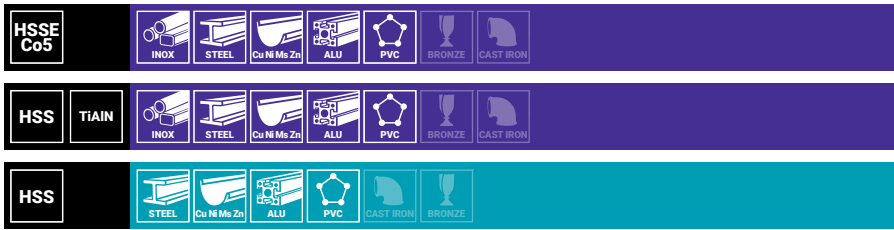

Auswerferstift: Art.-Nr. 108 304 (Ø 6.35 x 77.0 mm)

Verpackung: Kunststoff

Ø1 mm	Ø2 mm	L1 mm	Schnitttiefe mm	HSSE-Co 5	HSS TiAlN	HSS	
12.0	19.0	63.0	30.0	108 212 E	108 212 F	108 212	1
13.0	19.0	63.0	30.0	108 213 E	108 213 F	108 213	1
14.0	19.0	63.0	30.0	108 214 E	108 214 F	108 214	1
15.0	19.0	63.0	30.0	108 215 E	108 215 F	108 215	1
16.0	19.0	63.0	30.0	108 216 E	108 216 F	108 216	1
17.0	19.0	63.0	30.0	108 217 E	108 217 F	108 217	1
18.0	19.0	63.0	30.0	108 218 E	108 218 F	108 218	1
19.0	19.0	63.0	30.0	108 219 E	108 219 F	108 219	1
20.0	19.0	63.0	30.0	108 220 E	108 220 F	108 220	1
21.0	19.0	63.0	30.0	108 221 E	108 221 F	108 221	1
22.0	19.0	63.0	30.0	108 222 E	108 222 F	108 222	1
23.0	19.0	63.0	30.0	108 223 E	108 223 F	108 223	1
24.0	19.0	63.0	30.0	108 224 E	108 224 F	108 224	1
25.0	19.0	63.0	30.0	108 225 E	108 225 F	108 225	1
26.0	19.0	63.0	30.0	108 226 E	108 226 F	108 226	1
27.0	19.0	63.0	30.0	108 227 E	108 227 F	108 227	1
28.0	19.0	63.0	30.0	108 228 E	108 228 F	108 228	1
29.0	19.0	63.0	30.0	108 229 E	108 229 F	108 229	1
30.0	19.0	63.0	30.0	108 230 E	108 230 F	108 230	1
31.0	19.0	63.0	30.0	108 231 E	108 231 F	108 231	1
32.0	19.0	63.0	30.0	108 232 E	108 232 F	108 232	1
33.0	19.0	63.0	30.0	108 233 E	108 233 F	108 233	1
34.0	19.0	63.0	30.0	108 234 E	108 234 F	108 234	1
35.0	19.0	63.0	30.0	108 235 E	108 235 F	108 235	1
36.0	19.0	63.0	30.0	108 236 E	108 236 F	108 236	1
37.0	19.0	63.0	30.0	108 237 E	108 237 F	108 237	1
38.0	19.0	63.0	30.0	108 238 E	108 238 F	108 238	1
39.0	19.0	63.0	30.0	108 239 E	108 239 F	108 239	1
40.0	19.0	63.0	30.0	108 240 E	108 240 F	108 240	1
41.0	19.0	63.0	30.0	108 241 E	108 241 F	108 241	1
42.0	19.0	63.0	30.0	108 242 E	108 242 F	108 242	1
43.0	19.0	63.0	30.0	108 243 E	108 243 F	108 243	1
44.0	19.0	63.0	30.0	108 244 E	108 244 F	108 244	1
45.0	19.0	63.0	30.0	108 245 E	108 245 F	108 245	1
46.0	19.0	63.0	30.0	108 246 E	108 246 F	108 246	1
47.0	19.0	63.0	30.0	108 247 E	108 247 F	108 247	1
48.0	19.0	63.0	30.0	108 248 E	108 248 F	108 248	1
49.0	19.0	63.0	30.0	108 249 E	108 249 F	108 249	1
50.0	19.0	63.0	30.0	108 250 E	108 250 F	108 250	1
51.0	19.0	63.0	30.0	108 251 E	108 251 F	108 251	1
52.0	19.0	63.0	30.0	108 252 E	108 252 F	108 252	1
53.0	19.0	63.0	30.0	108 253 E	108 253 F	108 253	1
54.0	19.0	63.0	30.0	108 254 E	108 254 F	108 254	1
55.0	19.0	63.0	30.0	108 255 E	108 255 F	108 255	1
56.0	19.0	63.0	30.0	108 256 E	108 256 F	108 256	1
57.0	19.0	63.0	30.0	108 257 E	108 257 F	108 257	1
58.0	19.0	63.0	30.0	108 258 E	108 258 F	108 258	1
59.0	19.0	63.0	30.0	108 259 E	108 259 F	108 259	1
60.0	19.0	63.0	30.0	108 260 E	108 260 F	108 260	1



		HSSE-Co 5	HSS
<b>10</b> Stk./Pcs.	Kernbohrer-Satz Ø 12.0   14.0   16.0   18.0   20.0   22.0   24.0   26.0 mm + 1 Schneidpaste 40 ml   Art.-Nr. 101 021 + 1 Auswerferstift Ø 6.35 x 77.0 mm   Art.-Nr. 108 304	108 810 E	108 810



108 810 E

		HSS TiAIN	HSS
<b>7</b> Stk./Pcs.	Kernbohrer-Satz Ø 12.0   14.0   16.0   18.0   20.0   22.0 mm + 1 Auswerferstift Ø 6.35 x 77.0 mm   Art.-Nr. 108 304	108 820 F	108 820
<b>7</b> Stk./Pcs.	Kernbohrer-Satz 2x Ø 14.0 mm   2x Ø 18.0 mm   2x Ø 22.0 mm + 1 Auswerferstift Ø 6.35 x 77.0 mm   Art.-Nr. 108 304	108 840 F	108 840



108 840 F



108 840



## Kernbohrer HSS mit Weldonschaft, Schnitttiefe 110.0 mm – extra lang

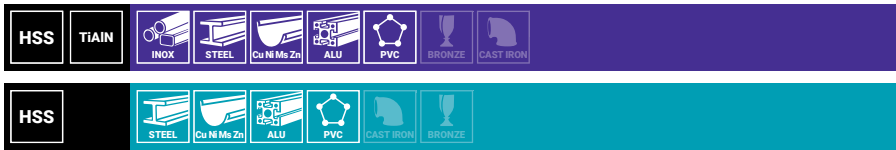

Auswerferstift: Art.-Nr. 108 2000 (Ø 8,0 x 155,0 mm)

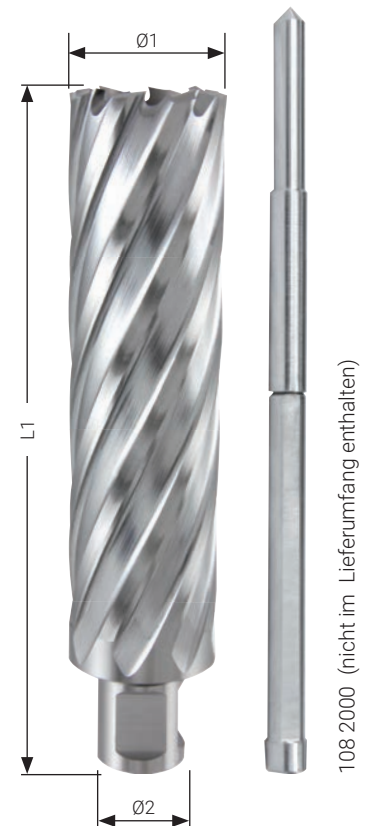

Verpackung: Kunststoff

Ø1 mm	Ø2 mm	L1 mm	Schnitttiefe mm	HSS TiAlN	HSS	
20.0	19.0	145.0	110.0	108 2020 F	108 2020	1
21.0	19.0	145.0	110.0	108 2021 F	108 2021	1
22.0	19.0	145.0	110.0	108 2022 F	108 2022	1
24.0	19.0	145.0	110.0	108 2024 F	108 2024	1
25.0	19.0	145.0	110.0	108 2025 F	108 2025	1
26.0	19.0	145.0	110.0	108 2026 F	108 2026	1
28.0	19.0	145.0	110.0	108 2028 F	108 2028	1
30.0	19.0	145.0	110.0	108 2030 F	108 2030	1
32.0	19.0	145.0	110.0	108 2032 F	108 2032	1

08



### Anwendungstipp

Kernbohrer aus dem Bohrloch fahren, die Späne, die sich im Bohrloch befinden, entfernen. Diesen Vorgang vermehrt wiederholen. Vermindert die Bruchgefahr und erhöht die Lebensdauer des Kernbohrers.



## Kernbohrer HSSE-Co 5 mit Quick IN-Schaft, Schnitttiefe 35.0 mm

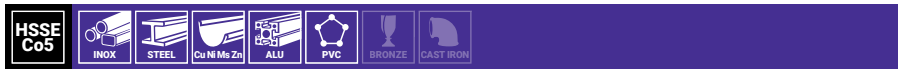

Auswerferstift: Art.-Nr. 108 306 (Ø 6.35 x 87.0 mm)  
 Maschine: mit Aufnahmehalter Quick IN-System

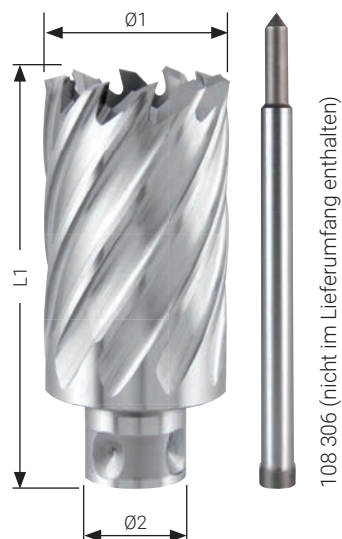

Verpackung: Kunststoff

Ø1 mm	Ø2 mm	L1 mm	Schnitttiefe mm	HSSE-Co 5	
12.0	18.0	77.0	35.0	108 912 E	1
13.0	18.0	77.0	35.0	108 913 E	1
14.0	18.0	77.0	35.0	108 914 E	1
15.0	18.0	77.0	35.0	108 915 E	1
16.0	18.0	77.0	35.0	108 916 E	1
17.0	18.0	77.0	35.0	108 917 E	1
18.0	18.0	77.0	35.0	108 918 E	1
19.0	18.0	77.0	35.0	108 919 E	1
20.0	18.0	77.0	35.0	108 920 E	1
21.0	18.0	77.0	35.0	108 921 E	1
22.0	18.0	77.0	35.0	108 922 E	1
23.0	18.0	77.0	35.0	108 923 E	1
24.0	18.0	77.0	35.0	108 924 E	1
25.0	18.0	77.0	35.0	108 925 E	1
26.0	18.0	77.0	35.0	108 926 E	1
27.0	18.0	77.0	35.0	108 927 E	1
28.0	18.0	77.0	35.0	108 928 E	1
29.0	18.0	77.0	35.0	108 929 E	1
30.0	18.0	77.0	35.0	108 930 E	1
32.0	18.0	77.0	35.0	108 932 E	1
35.0	18.0	77.0	35.0	108 935 E	1
36.0	18.0	77.0	35.0	108 936 E	1
40.0	18.0	77.0	35.0	108 940 E	1
45.0	18.0	77.0	35.0	108 945 E	1
50.0	18.0	77.0	35.0	108 950 E	1
55.0	18.0	77.0	35.0	108 955 E	1
60.0	18.0	77.0	35.0	108 960 E	1



		HSSE-Co 5
<b>10</b> tfg./pcs.	Kernbohrer -Satz HSSE-Co 5 Ø 12.0   14.0   16.0   18.0   20.0   22.0   24.0   26.0 mm + 1 Schneidpaste 40 ml   Art.-Nr. 101 021 + 1 Auswerferstift Ø 6.35 x 87.0 mm   Art.-Nr. 108 306	108 811 E





## Kernbohrer mit Hartmetallschneiden und Weldonschaft, Schnitttiefe 50.0 mm



Geeignet für Hardox / Weldox 400 Stähle

Auswerferstift: Ø 12.0 bis Ø 17.0 mm | Art.-Nr. 108 305 (Ø 6.35 x 102.0 mm)  
 Ø 18.0 bis Ø 50.0 mm | Art.-Nr. 108 701 (Ø 8.0 x 112.0 mm)

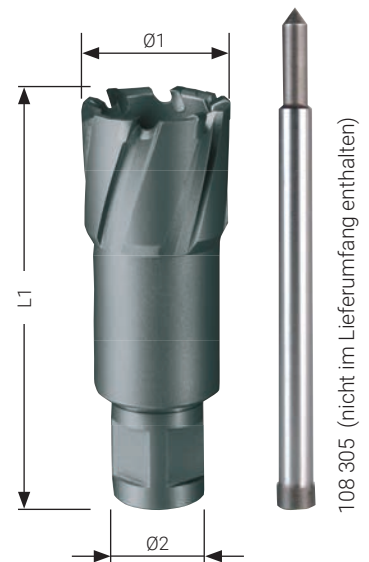

Verpackung: Kunststoff

Ø1 mm	Ø2 mm	L1 mm	Schnitttiefe mm	TC / HM	
12.0	19.0	84.0	50.0	108 712	1
13.0	19.0	84.0	50.0	108 713	1
14.0	19.0	84.0	50.0	108 714	1
15.0	19.0	84.0	50.0	108 715	1
16.0	19.0	84.0	50.0	108 716	1
17.0	19.0	84.0	50.0	108 717	1
18.0	19.0	84.0	50.0	108 718	1
19.0	19.0	84.0	50.0	108 719	1
20.0	19.0	84.0	50.0	108 720	1
21.0	19.0	84.0	50.0	108 721	1
22.0	19.0	84.0	50.0	108 722	1
23.0	19.0	84.0	50.0	108 723	1
24.0	19.0	84.0	50.0	108 724	1
25.0	19.0	84.0	50.0	108 725	1
26.0	19.0	84.0	50.0	108 726	1
27.0	19.0	84.0	50.0	108 727	1
28.0	19.0	84.0	50.0	108 728	1
29.0	19.0	84.0	50.0	108 729	1
30.0	19.0	84.0	50.0	108 730	1
31.0	19.0	84.0	50.0	108 731	1
32.0	19.0	84.0	50.0	108 732	1
33.0	19.0	84.0	50.0	108 733	1
34.0	19.0	84.0	50.0	108 734	1
35.0	19.0	84.0	50.0	108 735	1
36.0	19.0	84.0	50.0	108 736	1
37.0	19.0	84.0	50.0	108 737	1
38.0	19.0	84.0	50.0	108 738	1
39.0	19.0	84.0	50.0	108 739	1
40.0	19.0	84.0	50.0	108 740	1
41.0	19.0	84.0	50.0	108 741	1
42.0	19.0	84.0	50.0	108 742	1
43.0	19.0	84.0	50.0	108 743	1
44.0	19.0	84.0	50.0	108 744	1
45.0	19.0	84.0	50.0	108 745	1
46.0	19.0	84.0	50.0	108 746	1
47.0	19.0	84.0	50.0	108 747	1
48.0	19.0	84.0	50.0	108 748	1
49.0	19.0	84.0	50.0	108 749	1
50.0	19.0	84.0	50.0	108 750	1







## Kernbohrer mit Hartmetallschneiden und Quick IN-Schaft, Schnitttiefe 50.0 mm



Mit festem Schaft.

Maschine: mit Aufnahmehalter Quick IN-System

Auswerferstift: Art.-Nr. 108 305 (Ø 6.35 x 102.0 mm)

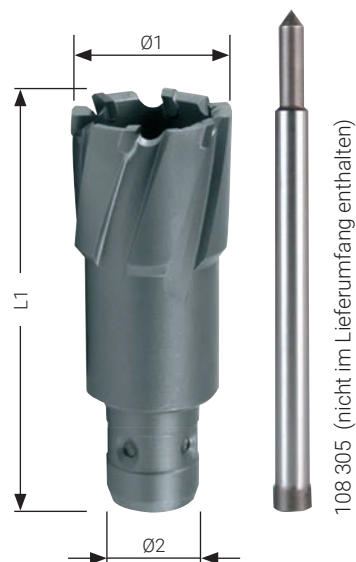

Verpackung: Kunststoff

Ø1 mm	Ø2 mm	L1 mm	Schnitttiefe mm	TC / HM	
12.0	18.0	83.0	50.0	108 1112	1
13.0	18.0	83.0	50.0	108 1113	1
14.0	18.0	83.0	50.0	108 1114	1
15.0	18.0	83.0	50.0	108 1115	1
16.0	18.0	83.0	50.0	108 1116	1
17.0	18.0	83.0	50.0	108 1117	1
18.0	18.0	83.0	50.0	108 1118	1
18.0	18.0	83.0	50.0	108 1118	1
20.0	18.0	83.0	50.0	108 1120	1
21.0	18.0	83.0	50.0	108 1121	1
22.0	18.0	83.0	50.0	108 1122	1
23.0	18.0	83.0	50.0	108 1123	1
24.0	18.0	83.0	50.0	108 1124	1
25.0	18.0	83.0	50.0	108 1125	1
26.0	18.0	83.0	50.0	108 1126	1
27.0	18.0	83.0	50.0	108 1127	1
28.0	18.0	83.0	50.0	108 1128	1
29.0	18.0	83.0	50.0	108 1129	1
30.0	18.0	83.0	50.0	108 1130	1
31.0	18.0	83.0	50.0	108 1131	1
32.0	18.0	83.0	50.0	108 1132	1



## Schneidpumpspraydose

Die RUKO Kühl- und Schmierstoffe zeigen eine hervorragende Trenn- und Kühlwirkung. Sie erzeugen eine hohe Oberflächengüte und erhöhen die Werkzeugstandzeiten auch bei harten und spröden Materialien.

<b>1</b> fig./pcs.	Hochleistungs-Schneidöl-Spray, 300 ml 100% reiner Wirkstoff - ohne Treibgas	101 012

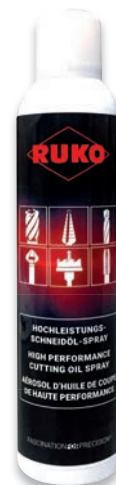



## Kernbohrer mit Hartmetallschneiden, Innengewinde, inklusive Adapter mit Quick IN-Schaft, Schnitttiefe 50.0 mm



Inklusive Adapter Quick IN-Schaft Art.-Nr. 108 111.  
 Maschine: mit Aufnahmehalter Quick IN-System  
 Auswerferstift: Ø 33.0 bis Ø 80.0 mm | Art.-Nr. 108 110 (Ø 6.35 x 123.0 mm)

Verpackung: Kunststoff

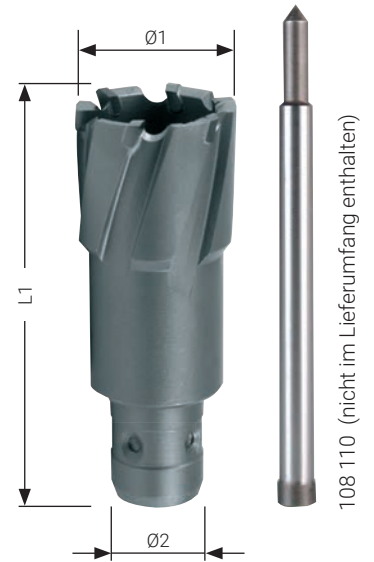

Ø1 mm	Ø2 mm	L1 mm	Schnitttiefe mm	TC / HM	
33.0	18.0	112.0	50.0	108 1133	1
34.0	18.0	112.0	50.0	108 1134	1
35.0	18.0	112.0	50.0	108 1135	1
36.0	18.0	112.0	50.0	108 1136	1
37.0	18.0	112.0	50.0	108 1137	1
38.0	18.0	112.0	50.0	108 1138	1
39.0	18.0	112.0	50.0	108 1139	1
40.0	18.0	112.0	50.0	108 1140	1
41.0	18.0	112.0	50.0	108 1141	1
42.0	18.0	112.0	50.0	108 1142	1
43.0	18.0	112.0	50.0	108 1143	1
44.0	18.0	112.0	50.0	108 1144	1
45.0	18.0	112.0	50.0	108 1145	1
46.0	18.0	112.0	50.0	108 1146	1
47.0	18.0	112.0	50.0	108 1147	1
48.0	18.0	112.0	50.0	108 1148	1
49.0	18.0	112.0	50.0	108 1149	1
50.0	18.0	112.0	50.0	108 1150	1
51.0	18.0	112.0	50.0	108 1151	1
52.0	18.0	112.0	50.0	108 1152	1
53.0	18.0	112.0	50.0	108 1153	1
54.0	18.0	112.0	50.0	108 1154	1
55.0	18.0	112.0	50.0	108 1155	1
60.0	18.0	112.0	50.0	108 1160	1
61.0	18.0	112.0	50.0	108 1161	1
63.0	18.0	112.0	50.0	108 1163	1
65.0	18.0	112.0	50.0	108 1165	1
68.0	18.0	112.0	50.0	108 1168	1
70.0	18.0	112.0	50.0	108 1170	1
71.0	18.0	112.0	50.0	108 1171	1
75.0	18.0	112.0	50.0	108 1175	1
80.0	18.0	112.0	50.0	108 1180	1





## Kernbohrer mit Hartmetallschneiden und Gewindeaufnahme, Schnitttiefe 50.0 mm



Auswerferstift: Art.-Nr. 108 110 (Ø 6.35 x 123.0 mm)  
 Aufnahme: Gewinde M18 x 6 P1,5

Verpackung: Kunststoff

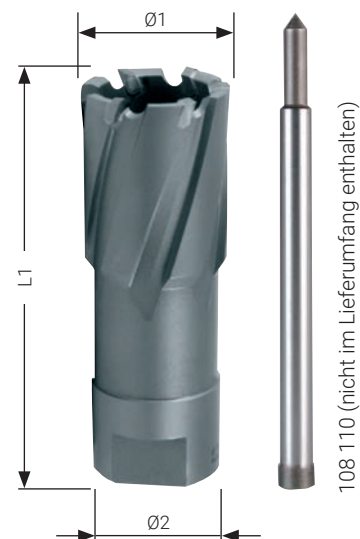

108 110 (nicht im Lieferumfang enthalten)

Ø1 mm	Ø2 mm	L1 mm	Schnitttiefe mm	TC / HM	
12.0	MK 2 / 3	84.0	50.0	108 012	1
13.0	MK 2 / 3	84.0	50.0	108 013	1
14.0	MK 2 / 3	84.0	50.0	108 014	1
15.0	MK 2 / 3	84.0	50.0	108 015	1
16.0	MK 2 / 3	84.0	50.0	108 016	1
17.0	MK 2 / 3	84.0	50.0	108 017	1
18.0	MK 2 / 3	84.0	50.0	108 018	1
19.0	MK 2 / 3	84.0	50.0	108 019	1
20.0	MK 2 / 3	84.0	50.0	108 020	1
21.0	MK 2 / 3	84.0	50.0	108 021	1
22.0	MK 2 / 3	84.0	50.0	108 022	1
23.0	MK 2 / 3	84.0	50.0	108 023	1
24.0	MK 2 / 3	84.0	50.0	108 024	1
25.0	MK 2 / 3	84.0	50.0	108 025	1
26.0	MK 2 / 3	84.0	50.0	108 026	1
27.0	MK 2 / 3	84.0	50.0	108 027	1
28.0	MK 2 / 3	84.0	50.0	108 028	1
29.0	MK 2 / 3	84.0	50.0	108 029	1
30.0	MK 2 / 3	84.0	50.0	108 030	1
31.0	MK 2 / 3	84.0	50.0	108 031	1
32.0	MK 2 / 3	84.0	50.0	108 032	1
33.0	MK 2 / 3	84.0	50.0	108 033	1
34.0	MK 2 / 3	84.0	50.0	108 034	1
35.0	MK 2 / 3	84.0	50.0	108 035	1
36.0	MK 2 / 3	84.0	50.0	108 036	1
37.0	MK 2 / 3	84.0	50.0	108 037	1
38.0	MK 2 / 3	84.0	50.0	108 038	1
39.0	MK 2 / 3	84.0	50.0	108 039	1
40.0	MK 2 / 3	84.0	50.0	108 040	1
41.0	MK 2 / 3	84.0	50.0	108 041	1
42.0	MK 2 / 3	84.0	50.0	108 042	1
43.0	MK 2 / 3	84.0	50.0	108 043	1
44.0	MK 2 / 3	84.0	50.0	108 044	1
45.0	MK 2 / 3	84.0	50.0	108 045	1
46.0	MK 2 / 3	84.0	50.0	108 046	1
47.0	MK 2 / 3	84.0	50.0	108 047	1
48.0	MK 2 / 3	84.0	50.0	108 048	1
49.0	MK 2 / 3	84.0	50.0	108 049	1
50.0	MK 2 / 3	84.0	50.0	108 050	1
51.0	MK 2 / 3	84.0	50.0	108 051	1
52.0	MK 2 / 3	84.0	50.0	108 052	1
53.0	MK 2 / 3	84.0	50.0	108 053	1
54.0	MK 2 / 3	84.0	50.0	108 054	1
55.0	MK 2 / 3	84.0	50.0	108 055	1
60.0	MK 2 / 3	84.0	50.0	108 060	1
61.0	MK 2 / 3	84.0	50.0	108 061	1
63.0	MK 2 / 3	84.0	50.0	108 063	1
65.0	MK 2 / 3	84.0	50.0	108 065	1
68.0	MK 2 / 3	84.0	50.0	108 068	1
70.0	MK 2 / 3	84.0	50.0	108 070	1
71.0	MK 2 / 3	84.0	50.0	108 071	1
75.0	MK 2 / 3	84.0	50.0	108 075	1
80.0	MK 2 / 3	84.0	50.0	108 080	1





## Kernbohrer mit Hartmetallschneiden und Weldonschaft für Eisenbahnschienen, Schnitttiefe 30.0 mm



Einsetzbar auf allen Schienenbohrgeräten. Die Schneidengeometrie ist besonders auf die Scher-  
 zerspannung von Eisenbahnschienen optimiert worden und macht dadurch einen wirtschaftlichen  
 Einsatz möglich.

Auswerferstift: Art.-Nr. 108 1510 (Ø 8.0 x 81.0 mm)

Verpackung: Kunststoff

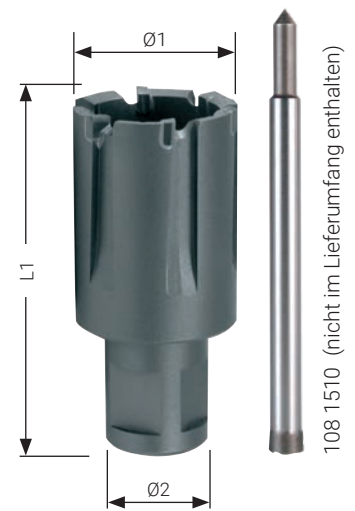

Ø1 mm	Ø2 mm	L1 mm	Schnitttiefe mm	TC / HM	
19.0	19.0	63.0	30.0	108 1519	1
20.0	19.0	63.0	30.0	108 1520	1
21.0	19.0	63.0	30.0	108 1521	1
22.0	19.0	63.0	30.0	108 1522	1
23.0	19.0	63.0	30.0	108 1523	1
24.0	19.0	63.0	30.0	108 1524	1
25.0	19.0	63.0	30.0	108 1525	1
26.0	19.0	63.0	30.0	108 1526	1
26.5	19.0	63.0	30.0	108 15265	1
27.0	19.0	63.0	30.0	108 1527	1
27.5	19.0	63.0	30.0	108 15275	1
28.0	19.0	63.0	30.0	108 1528	1
29.0	19.0	63.0	30.0	108 1529	1
30.0	19.0	63.0	30.0	108 1530	1
31.0	19.0	63.0	30.0	108 1531	1
32.0	19.0	63.0	30.0	108 1532	1
33.0	19.0	63.0	30.0	108 1533	1
34.0	19.0	63.0	30.0	108 1534	1
36.0	19.0	63.0	30.0	108 1536	1



## Auswerferstifte für Kernbohrer HSS

Verpackung: Kunststoff

	Schnitttiefe Kernbohrer mm	HSS	
Auswerferstift Ø 6.35 x 77.0 mm für Kernbohrer HSS mit Weldonschaft	30.0	108 304	1
Auswerferstift Ø 6.35 x 87.0 mm für Kernbohrer HSS / HM mit Quick IN-Schaft	35.0 / 50.0	108 306	1
Auswerferstift Ø 6.35 x 102.0 mm für Kernbohrer HSS / HM mit Weldonschaft	55.0	108 305	1
Auswerferstift Ø 8.0 x 155.0 mm für Kernbohrer HSS mit Weldonschaft	110.0	108 2000	1



## Auswerferstifte für Kernbohrer HM

Verpackung: Kunststoff

	Schnitttiefe Kernbohrer mm	HSS	
Auswerferstift Ø 8.0 x 81.0 mm für Kernbohrer HM mit Weldonschaft für Eisenbahnschienen	30.0	108 1510	1
Auswerferstift Ø 6.35 x 87.0 mm für Kernbohrer HSS / HM mit Quick IN-Schaft	35.0 / 50.0	108 306	1
Auswerferstift Ø 8.0 x 112.0 mm für Kernbohrer HM mit Weldonschaft	50.0	108 701	1
Auswerferstift Ø 6.35 x 123.0 mm für Kernbohrer HM mit Weldon- und Quick IN-Schaft	50.0 + Adapter	108 110	1
Auswerferstift Ø 6.35 x 102.0 mm für Kernbohrer HSS / HM mit Weldonschaft	55.0	108 305	1

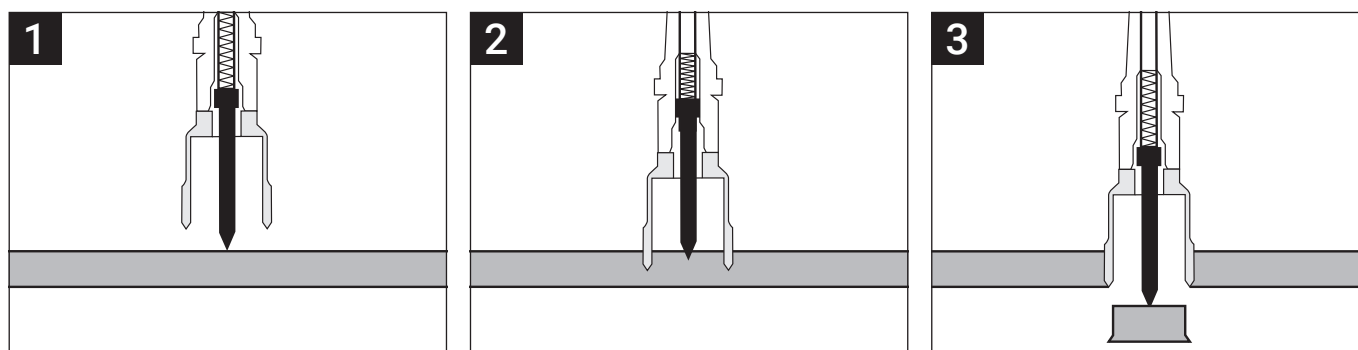

- 1 Zentrieren**  
Positionieren Sie den Auswerferstift mittig auf den Körner. Nun befindet sich die Maschine in der richtigen Bohrposition. Bitte schalten Sie den Magnet jetzt an.
- 2 Kühlmittelzufuhr**  
Das Schneidöl wird mittels der automatischen Innenschmierung über den Auswerferstift an diesem abgeführt und optimal dosiert an die Schneiden abgegeben.
- 3 Auswerfen**  
In der Endphase der Bohrung wird der Bohrkern durch den mit einer Feder vorgespannten Auswerferstift aus dem Bohrloch gedrückt.

# Drehzahlrichtwerte für Kernbohrer HSS

Material		unlegierter Baustahl bis 700 N/mm <sup>2</sup>	legierter Stahl bis 1000 N/mm <sup>2</sup>	Guss-eisen über 250 N/mm <sup>2</sup>	CuZn-Legierung spröde	CuZn-Legierung zäh	Aluminium-Legierung bis 11% Si	Thermo-plaste	Duro-plaste
Vc = m/min		30	20	10	60	35	30	20	15
Kühlschmierstoff		Schneidspray	Schneidspray	Druckluft	Druckluft	Druckluft	Schneidspray	Wasser	Druckluft
Ø mm	Ø Zoll	U/min	U/min	U/min	U/min	U/min	U/min	U/min	U/min
12.0	1/2	796	531	265	1592	929	796	531	398
13.0	3/8	735	490	245	1470	857	735	490	367
14.0	1/2	682	455	227	1365	796	682	455	341
15.0	9/16	637	425	212	1274	743	637	425	318
16.0	5/8	597	398	199	1194	697	597	398	299
17.0	3/4	562	375	187	1124	656	562	375	281
18.0	1/2	531	354	177	1062	619	531	354	265
19.0	3/4	503	335	168	1006	587	503	335	251
20.0	1/2	478	318	159	955	557	478	318	239
21.0	3/4	455	303	152	910	531	455	303	227
22.0	7/8	434	290	145	869	507	434	290	217
23.0	1/2	415	277	138	831	485	415	277	208
24.0	1/2	398	265	133	796	464	398	265	199
25.0	3/4	382	255	127	764	446	382	255	191
26.0	1 1/8	367	245	122	735	429	367	245	184
27.0	1 1/4	354	236	118	708	413	354	236	177
28.0	1 1/2	341	227	114	682	398	341	227	171
29.0	1 3/8	329	220	110	659	384	329	220	165
30.0	1 1/2	318	212	106	637	372	318	212	159
31.0	1 7/8	308	205	103	616	360	308	205	154
32.0	1 1/2	299	199	100	597	348	299	199	149
33.0	1 1/2	290	193	97	579	338	290	193	145
34.0	1 1/2	281	187	94	562	328	281	187	141
35.0	1 3/4	273	182	91	546	318	273	182	136
36.0	1 1/2	265	177	88	531	310	265	177	133
37.0	1 1/2	258	172	86	516	301	258	172	129
38.0	1 1/2	251	168	84	503	293	251	168	126
39.0	1 1/2	245	163	82	490	286	245	163	122
40.0	1 3/4	239	159	80	478	279	239	159	119
41.0	1 3/4	233	155	78	466	272	233	155	117
42.0	1 1/2	227	152	76	455	265	227	152	114
43.0	1 1/2	222	148	74	444	259	222	148	111
44.0	1 3/4	217	145	72	434	253	217	145	109
45.0	1 1/2	212	142	71	425	248	212	142	106
46.0	1 1/2	208	138	69	415	242	208	138	104
47.0	1 3/4	203	136	68	407	237	203	136	102
48.0	1 3/4	199	133	66	398	232	199	133	100
49.0	1 1/2	195	130	65	390	227	195	130	97
50.0	1 3/4	191	127	64	382	223	191	127	96
51.0	2	187	125	62	375	219	187	125	94
52.0	2 1/8	184	122	61	367	214	184	122	92
53.0	2 1/4	180	120	60	361	210	180	120	90
54.0	2 1/8	177	118	59	354	206	177	118	88
55.0	2 1/4	174	116	58	347	203	174	116	87
60.0	2 3/8	159	106	53	318	186	159	106	80



# Drehzahlrichtwerte für Kernbohrer mit Hartmetallschneiden

Material		unlegierter Baustahl bis 700 N/mm <sup>2</sup>	legierter Stahl bis 1000 N/mm <sup>2</sup>	Guss- eisen über 250 N/mm <sup>2</sup>	CuZn- Legierung spröde	CuZn- Legierung zäh	Aluminium- Legierung bis 11% Si	Thermo- plaste	Duro- plaste
V <sub>c</sub> = m/min		50	35	40	60	40	60	45	40
Kühlschmierstoff		Schneidspray	Schneidspray	Druckluft	Druckluft	Druckluft	Schneidspray	Wasser	Druckluft
Ø mm	Ø Zoll	U/min	U/min	U/min	U/min	U/min	U/min	U/min	U/min
12.0	15/32	1327	929	1062	1592	265	1592	1194	1062
13.0	33/64	1225	857	980	1470	245	1470	1102	980
14.0	35/64	1137	796	910	1365	227	1365	1024	910
15.0	19/32	1062	743	849	1274	212	1274	955	849
16.0	5/8	995	697	796	1194	199	1194	896	796
17.0	34/64	937	656	749	1124	187	1124	843	749
18.0	45/64	885	619	708	1062	177	1062	796	708
19.0	3/4	838	587	670	1006	168	1006	754	670
20.0	25/32	796	557	637	955	159	955	717	637
21.0	3/4	758	531	607	910	152	910	682	607
22.0	7/8	724	507	579	869	145	869	651	579
23.0	13/16	692	485	554	831	138	831	623	554
24.0	15/16	663	464	531	796	133	796	597	531
25.0	63/64	637	446	510	764	127	764	573	510
26.0	1 1/32	612	429	490	735	122	735	551	490
27.0	1 1/16	590	413	472	708	118	708	531	472
28.0	1 3/32	569	398	455	682	114	682	512	455
29.0	1 9/64	549	384	439	659	110	659	494	439
30.0	1 3/16	531	372	425	637	106	637	478	425
31.0	1 7/32	514	360	411	616	103	616	462	411
32.0	1 17/64	498	348	398	597	100	597	448	398
33.0	1 19/64	483	338	386	579	97	579	434	386
34.0	1 11/32	468	328	375	562	94	562	422	375
35.0	1 3/8	455	318	364	546	91	546	409	364
36.0	1 27/64	442	310	354	531	88	531	398	354
37.0	1 29/64	430	301	344	516	86	516	387	344
38.0	1 1/2	419	293	335	503	84	503	377	335
39.0	1 17/32	408	286	327	490	82	490	367	327
40.0	1 37/64	398	279	318	478	80	478	358	318
41.0	1 39/64	388	272	311	466	78	466	350	311
42.0	1 21/32	379	265	303	455	76	455	341	303
43.0	1 11/16	370	259	296	444	74	444	333	296
44.0	1 47/64	362	253	290	434	72	434	326	290
45.0	1 25/32	354	248	283	425	71	425	318	283
46.0	1 13/16	346	242	277	415	69	415	312	277
47.0	1 55/64	339	237	271	407	68	407	305	271
48.0	1 57/64	332	232	265	398	66	398	299	265
49.0	1 15/16	325	227	260	390	65	390	292	260
50.0	1 31/32	318	223	255	382	64	382	287	255
51.0	2	312	219	250	375	62	375	281	250
52.0	2 3/64	306	214	245	367	61	367	276	245
53.0	2 3/32	300	210	240	361	60	361	270	240
54.0	2 1/8	295	206	236	354	59	354	265	236
55.0	2 5/32	290	203	232	347	58	347	261	232
60.0	2 3/8	265	186	212	318	53	318	239	212
61.0	2 13/32	261	183	209	313	52	313	235	209
65.0	2 9/16	245	171	196	294	49	294	220	196
68.0	2 43/64	234	164	187	281	47	281	211	187
70.0	2 3/4	227	159	182	273	45	273	205	182
71.0	2 51/64	224	157	179	269	45	269	202	179
75.0	2 61/64	212	149	170	255	42	255	191	170
80.0	3 5/32	199	139	159	239	40	239	179	159
85.0	3 11/32	187	131	150	225	37	225	169	150
90.0	3 35/64	177	124	142	212	35	212	159	142
95.0	3 47/64	168	117	134	201	34	201	151	134
100.0	3 15/16	159	111	127	191	32	191	143	127



08

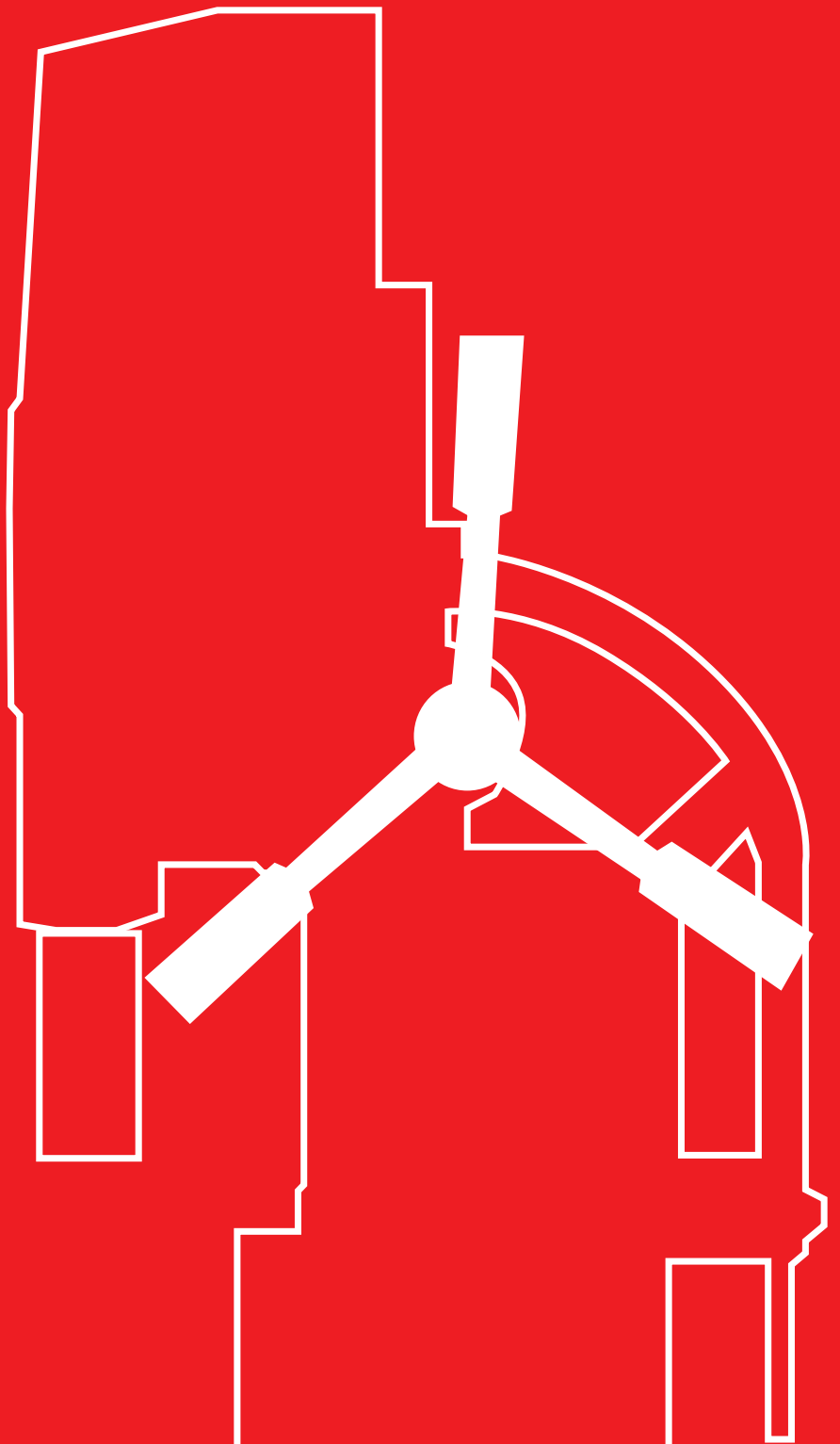



# KERNBOHRTECHNIK

## MAGNETBOHRMASCHINEN

Magnetbohrmaschine A10	210 – 211
Magnetbohrmaschine RU25	212 – 213
Magnetbohrmaschine RU40	214 – 215
Die RUKO Magnetbohrmaschinen im Überblick	216 – 217
Aufnahmehalter für Kernbohrer mit Weldonschaft	218
Aufnahmehalter mit Schnellspannaufnahme EasyLock für Kernbohrer mit Weldonschaft	218
Aufnahmehalter für Gewindebohrer M 27 + M 30	219
Aufnahmehalter für Schnellwechseleinsätze zum Gewindeschneiden	219
Schnellwechseleinsätze mit Sicherheitskupplung für Durchgangs- und Sacklochbohrungen	219
Übersicht Gewindebohrer Schaftdurchmesser	219
Adapter, Bohrfutter und Zubehör für Magnetbohrmaschinen	220
Magnetspäneheber	220

**Pure Kraft – damit jeder Durchbruch gelingt**





# A10

## Magnetbohrmaschine A10

Die Handliche

- 10.000 N Haftkraft
- Höhenverstellbare Antriebseinheit durch doppelte Schwalbenschwanzführung
- Sehr leicht / einfache Handhabung
- Automatische Kühlmittelzufuhr
- Leichtes Nachjustieren durch 50 % Magnethaftkraftreduzierung bei ausgeschaltetem Motor



## Technische Daten



08

	Magnetische Haftkraft: 10.000 N
	Leistungsaufnahme: 1.100 Watt
	Drehzahlen: 700 U/min
	Höhe: 400.0 – 580.0 mm
	Hub: 120.0 / 195.0 mm
	Aufstandsfläche: 160.0 x 80.0 mm

	Gewicht: 10.5 kg
	Aufnahme: Weldonschaft: 19.0 mm (3/4")
	Bohrfutter: Ø 1.0 - 13.0 mm mit Adapter 108 109
	Schnitttiefe Kernbohrer: bis 50.0 mm
	Anschlussspannung: 220 – 240 Volt
	Entspricht: VDE. CEE

	Kernbohrer: Ø 12.0 – 35.0 mm
	Spiralbohrer: DIN 338: max. Ø 13.0 mm
	–
	–

## Magnetbohrmaschine A10 im Transportkoffer

	1 Aufnahmehalter mit Weldonaufnahme 1 Sicherungsgurt 3 Innensechskantschlüssel 2.5 / 4 / 6 1 Kühlmittelflasche 1 Bedienungsanleitung	108 010 A



# Verwendung von Zubehör

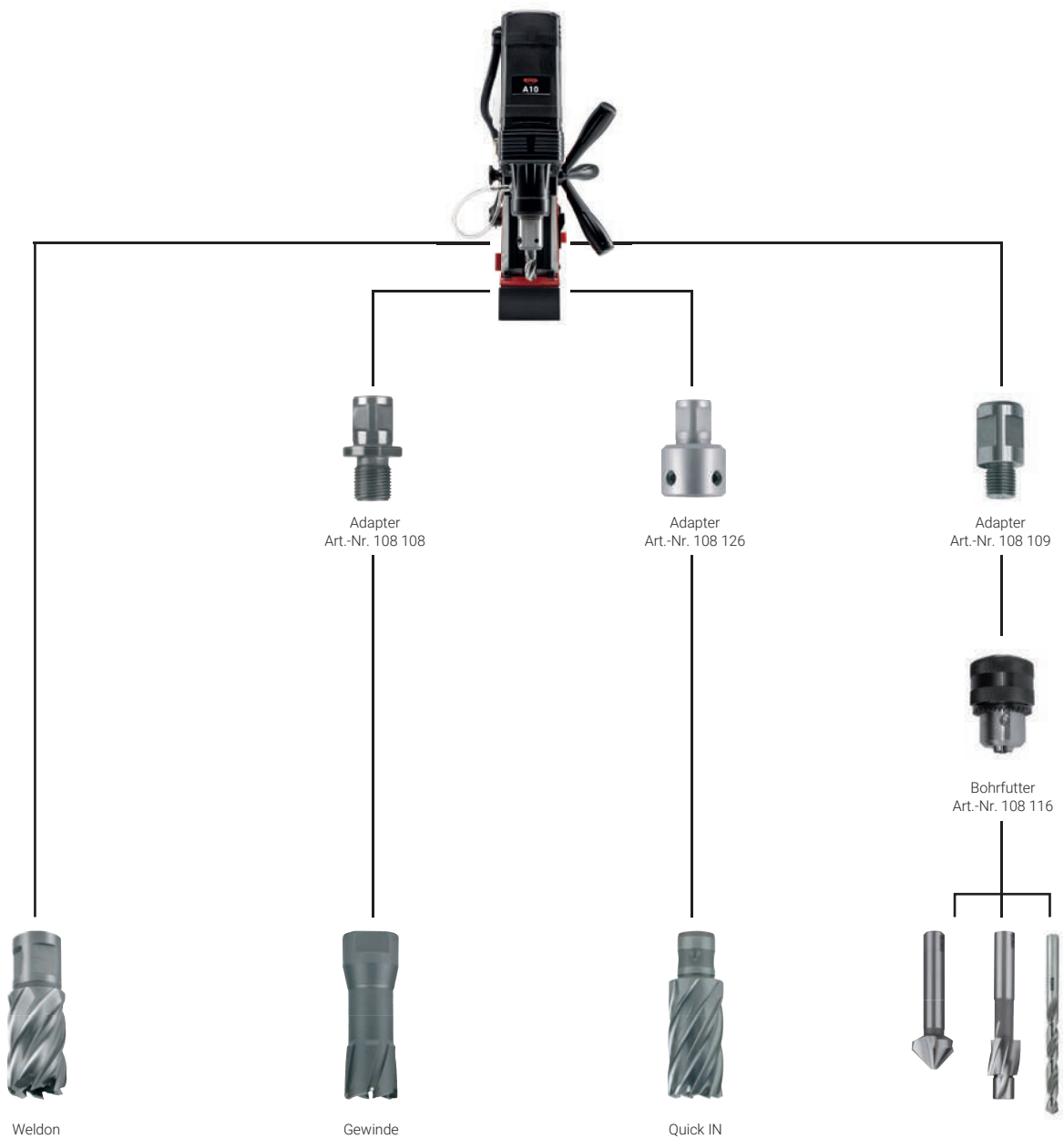

# RU25

## Magnetbohrmaschine RU25

Die Vielseitige

- 16.000 N Haftkraft
- Höhenverstellbare Antriebseinheit durch doppelte Schwalbenschwanzführung
- Rechts-/ Linkslauf
- 2-Gang-Getriebe
- Drehzahlregler
- Leistungsstarker Motor
- Leicht und handlich







## Technische Daten



08

	Magnetische Haftkraft: 16.000 N
	Leistungsaufnahme: 1.200 Watt
	Drehzahlen U/min: 100 – 250   180 - 450 U/min
	Höhe: 529.0 – 629.0 mm
	Hub: 170.0 mm
	Aufstandsfläche: 238.0 x 92.0 mm

	Gewicht: 16.0 kg
	Aufnahme: Morsekegel MK 2
	Bohrfutter: 3.0 – 16.0 mm
	Schnitttiefe Kernbohrer: bis 55.0 mm
	Anschlussspannung: 220 – 240 Volt
	Entspricht: VDE, CEE

	Kernbohrer: Ø 12.0 – 50.0 mm
	Kegelsenker: Ø 10.0 – 40.0 mm
	Spiralbohrer: DIN 338/1897: max. Ø 16.0 mm DIN 345: max. Ø 20.0 mm
	Gewinde: M 3 – M 20

## Magnetbohrmaschine RU25 im Transportkoffer

		
	1 Innensechskantschlüssel 2.5 / 6 1 Sicherheitsgurt 1 Bohrfutter Ø 1.0 - 16.0 mm 1 Aufnahmehalter mit MK 2 Aufnahme 1 Kühlmittelflasche 1 Spänehooken 1 Hochleistungs-Schneidöl-Spray 1 Bedienungsanleitung	108 025 RU



# Verwendung von Zubehör



Aufnahmehalter  
MK 2  
Art-Nr. 108 302-1



Aufnahmehalter  
EasyLock  
Art-Nr. 108 312-1



Aufnahmehalter  
MK 2  
Art-Nr. 108 102-1



Schnellspann-  
aufnahme MK 2  
Art-Nr. 108 163



Kegeldorn  
MK 2  
Art-Nr. 108 120



Adapter  
Art-Nr. 108 126



Adapter  
Art-Nr. 108 108



Schnellwechseleinsatz  
mit und ohne  
Sicherheitskupplung



Bohrfutter  
Art-Nr. 108 117



Quick IN



Gewinde



Weldon



Gewinde



08

# RU40

## Magnetbohrmaschine RU40

Die Leistungsstärke

- 20.000 N Haftkraft
- Höhenverstellbare Antriebseinheit durch doppelte Schwalbenschwanzführung
- Rechts- / Linkslauf
- 4-Gang-Getriebe
- Drehzahlregler
- Leistungsstarker Motor
- Serienmäßige Feinverstellung gedämpft
- Verschiebbarkeit: +/-10,0 mm
- Schwenkbereich: +/- 30°







## Technische Daten



08

	Magnetische Haftkraft: 20.000 N
	Leistungsaufnahme: 1.800 Watt
	Drehzahlen U/min: 50 - 110   75 - 175 U/min 105 - 245   165 - 385 U/min
	Höhe: 642.0 - 702.0 mm
	Hub: 190.0 mm
	Aufstandsfläche: 238.0 x 92.0 mm

	Gewicht: 22.0 kg
	Aufnahme: Morsekegel MK 3
	Bohrfutter: 3.0 - 16.0 mm
	Schnitttiefe Kernbohrer: bis 110.0 mm
	Anschlussspannung: 220 - 240 Volt
	Entspricht: VDE. CEE

	Kernbohrer: Ø 12.0 - 80.0 mm
	Kegelsenker: Ø 10.0 - 55.0 mm
	Spiralbohrer: DIN 338/1897: max. Ø 16.0 mm DIN 345: max. Ø 32.0 mm
	Gewinde: M 3 - M 30

## Magnetbohrmaschine RU40 im Transportkoffer

		
	<ul style="list-style-type: none"> <li>1 Innensechskantschlüssel 2.5 / 6</li> <li>1 Sicherheitsgurt</li> <li>1 Bohrfutter Ø 1.0 - 16.0 mm</li> <li>1 Aufnahmehalter mit MK 3 Aufnahme</li> <li>1 Kühlmittelflasche</li> <li>1 Spänehook</li> <li>1 Hochleistungs-Schneidöl-Spray</li> <li>1 Bedienungsanleitung</li> </ul>	108 040 RU





# Verwendung von Zubehör

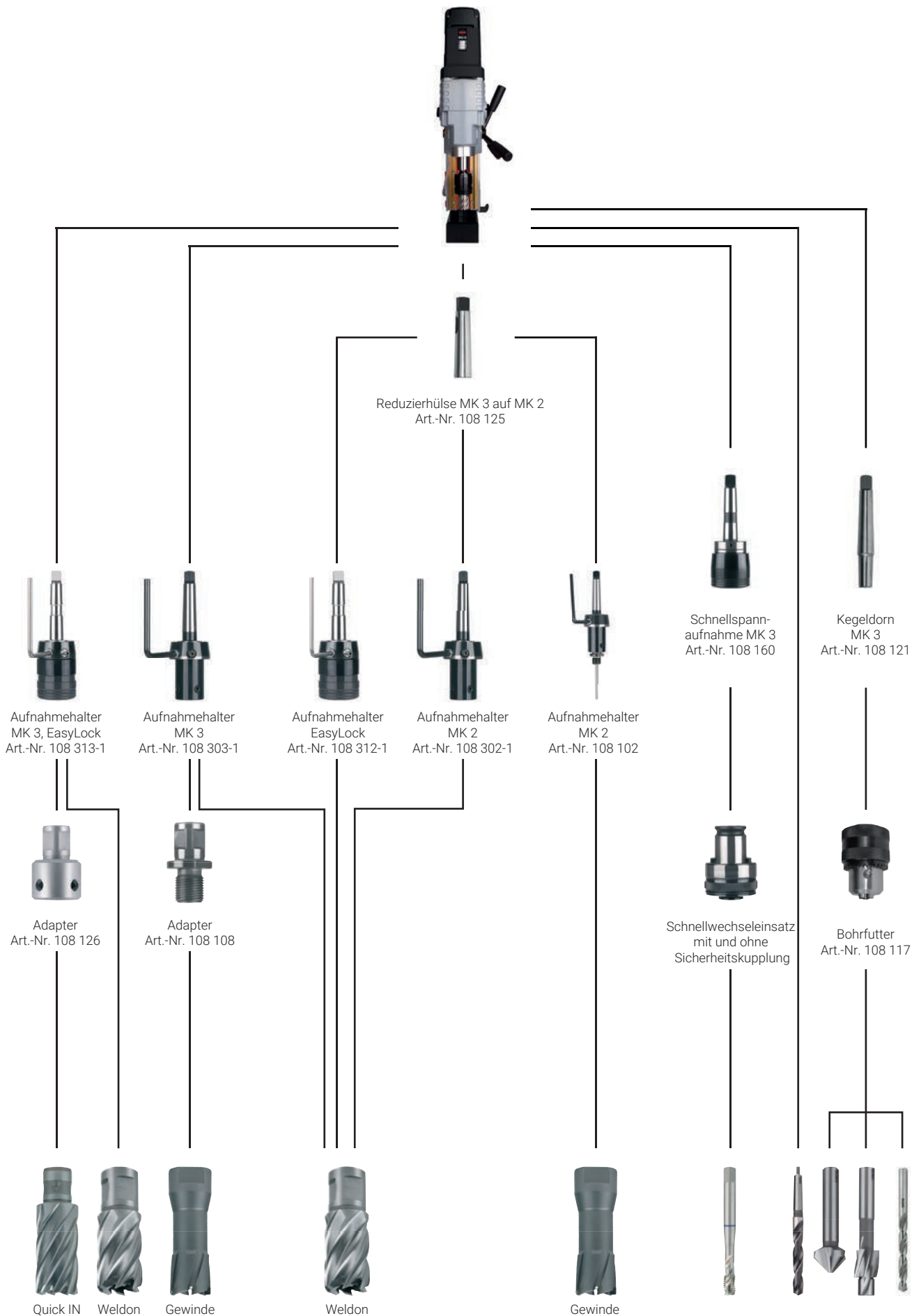























# Die RUKO Magnetbohrmaschinen im Überblick

## Technische Daten

# A 10

Art.-Nr. 108 010 A

	Magnetische Haftkraft	10.000 N
	Leistungsaufnahme	1.100 Watt
	Gänge	1 Gang
	Drehzahlen U/min	700 U/min
	Drehzahlregler	–
	Rechts-/ Linkslauf	–
	Höhe	400.0 – 580.0 mm
	Aufstandsfläche	160.0 x 80.0 mm
	Gewicht	10.5 kg
	Hub	120.0 / 195.0 mm
	Aufnahme	Weldonschaft 19.0 mm (3/4")
	Kernbohrer	12.0 – 35.0 mm
	Bohrfutter	3.0 – 16.0 mm
	Spiralbohrer DIN 338/1897	max. Ø 13.0 mm
	Spiralbohrer DIN 345	–
	Kegelsenker	–
	Schnitttiefe Kernbohrer	max. 50.0 mm
	Anschlussspannung	220 – 240 V
	Entspricht	VDE. CEE
	Verschiebbarkeit	–
	Schwenkbereich	–
	Gewindeschneiden	–
	Gewinde	–

Transportkoffer aus Kunststoff
Aufnahmehalter mit Weldonaufnahme
Innensechskantschlüssel 2.5 / 4 / 6
Sicherheitsgurt
Bohrfutter 1.0 – 13.0 mm mit Adapter 108 109
Kühlmittelflasche
–
–
Bedienungsanleitung



## RU 25 Art.-Nr. 108 025 RU

16.000 N
1.200 Watt
2 Gänge
100 – 250   180 – 450 U/min
✓
✓
529.0 – 629.0 mm
238.0 x 92.0 mm
16.0 kg
170.0 mm
Morsekegel MK 2
Ø 12.0 – 50.0 mm
1.0 – 16.0 mm
max. Ø 16.0 mm
max. Ø 20.0 mm
Ø 10.0 – 40.0 mm
max. 55.0 mm
220 – 240 V
VDE. CEE
–
–
✓
M 3 – M 20

Transportkoffer aus Kunststoff
Aufnahmehalter mit MK 2 Aufnahme
Innensechskantschlüssel 2.5 / 6
Sicherheitsgurt
Bohrfutter 3.0 – 16.0 mm
Kühlmittelflasche
Spänehooken
Hochleistungs-Schneidöl-Spray
Bedienungsanleitung

## RU 40 Art.-Nr. 108 040 RU

20.000 N
1.800 Watt
4 Gänge
50 – 110   75 – 175   105 – 245   165 – 385 U/min
✓
✓
642.0 – 702.0 mm
238.0 x 92.0 mm
22.0 kg
190.0 mm
Morsekegel MK 3
Ø 12.0 – 80.0 mm
1.0 – 16.0 mm
max. Ø 16.0 mm
max. Ø 32.0 mm
Ø 10.0 – 55.0 mm
max. 110.0 mm
220 – 240 V
VDE. CEE
+/- 10.0 mm
+/- 30°
✓
M 3 – M 30



Transportkoffer aus Kunststoff
Aufnahmehalter mit MK 3 Aufnahme
Innensechskantschlüssel 2.5 / 6
Sicherheitsgurt
Bohrfutter 3.0 – 16.0 mm
Kühlmittelflasche
Spänehooken
Hochleistungs-Schneidöl-Spray
Bedienungsanleitung



08

## Aufnahmehalter für Kernbohrer mit Weldonschaft

Verpackung: Kunststoff



		
Aufnahmehalter mit MK 2 Schaft für Kernbohrer Ø 10.0 - 60.0 mm	<b>RU 25</b>	108 302-1 1
Aufnahmehalter mit MK 3 Schaft für Kernbohrer Ø 10.0 - 100.0 mm	<b>RU 40</b>	108 303-1 1



## Aufnahmehalter mit Schnellspannaufnahme EasyLock für Kernbohrer mit Weldonschaft

Die Schnellspannaufnahme EasyLock ermöglicht einen sehr schnellen Werkzeugwechsel ohne Zusatzwerkzeuge. Mit einer Hand bedienbar.

Verpackung: Kunststoff

		
EasyLock mit MK 2 Schaft für Kernbohrer Ø 10.0 - 60.0 mm	<b>RU 25</b>	108 312-1 1
EasyLock mit MK 3 Schaft für Kernbohrer Ø 10.0 - 100.0 mm	<b>RU 40</b>	108 313-1 1



**i**



### Anwendungstipp

- 1** Schieben Sie den Arretierungsring nach oben, bis dieser festsetzt.
- 2** Stecken Sie den Kernbohrer in die EasyLock. Dieser arretiert mit einem lauten "Klick". Der Arretierungsring schnappt nach unten.
- 3** Der Kernbohrer steckt in der EasyLock. Die Maschine ist nun betriebsbereit.
- 4** Um den Kernbohrer zu lösen, schieben Sie den Arretierungsring nach oben.
- 5** Achtung! Der Kernbohrer fällt aus der EasyLock.



## Aufnahmehalter für Gewindebohrer



Verpackung: Kunststoff

			
Aufnahmehalter mit MK 3 Schaft für Gewindebohrer M 27	<b>RU 40</b>	108 161	1
Aufnahmehalter mit MK 3 Schaft für Gewindebohrer M 30		108 162	1



## Schnellspannaufnahme für Schnellwechseleinsätze





Verpackung: Kunststoff

			
Schnellspannaufnahme mit MK 2 Schaft und Längenausgleich -5,0/+10,0 mm für Schnellwechseleinsätze	<b>RU 25</b>	108 163	1
Schnellspannaufnahme mit MK 3 Schaft und Längenausgleich +/-10,0 mm für Schnellwechseleinsätze	<b>RU 40</b>	108 160	1



## Schnellwechseleinsätze mit Sicherheitskupplung für Durchgangs- und Sacklochbohrungen

Verpackung: Kunststoff

Gewindebohrer Ø-Schaft mm			Gewindebohrer Ø-Schaft mm		
6.0	108 166	1	11.0	108 171	1
7.0	108 167	1	12.0	108 172	1
8.0	108 168	1	14.0	108 173	1
9.0	108 169	1	16.0	108 174	1
10.0	108 170	1	18.0	108 175	1





## Übersicht Gewindebohrer Schaftdurchmesser

Ø-Schaft mm	DIN 352	DIN 357 / DIN 376	DIN 371	UNC / UNF ≈ DIN 371	DIN 374	UNC / UNF ≈ DIN 376	DIN 5156	DIN 40433
6.0	M 4.5 - M 8	M 8	M 5 / M 6	Nr. 10/12 / 1/4"	MF 8		G 1/8"	PG 7
7.0	M 9 / M 10	M 9 / M 10	M 7		MF 10			
8.0	M 11	M 11	M 8	5/16"		7/16"		
9.0	M 12	M 12	M 9		MF 12	1/2"		PG 9
10.0			M 10	3/8"				
11.0	M 14	M 14			MF 14	9/16"	G 1/4"	PG 11
12.0	M 16	M 16			MF 16	5/8"	G 3/8"	PG 13.5
14.0	M 18	M 18			MF 18	3/4"		
16.0	M 20	M 20			MF 20		G 1/2"	
18.0	M 22 / M 24	M 22 / M 24			MF 22 / MF 24	7/8" / 1"		PG 21

# Adapter, Bohrfutter und Zubehör für Magnetbohrmaschinen

Verpackung: Kunststoff



			
Adapter mit Weldonschaft 3/4" für Kernbohrer mit Gewindeaufnahme M18 x 6 P1,5	<b>A10   RU25   RU40</b>	108 108	1
Adapter mit Weldonschaft 3/4" für Kernbohrer mit Quick IN-Schaft	<b>A10   RU25   RU40</b>	108 126	1
Adapter mit Quick IN-Schaft für Kernbohrer mit Gewindeaufnahme M18 x 6 P1,5	mit Quick IN-Aufnahme	108 111	1
Adapter mit Quick IN-Schaft für Kernbohrer mit Weldonenschaft 3/4"	mit Quick IN-Aufnahme	108 118	1
Bohrfutter mit Gewindeaufnahme 1/2" UNF für Ø 1,0 - 13,0 mm	<b>A10</b>	108 116	1
Bohrfutter mit Kegelaufnahme B16 für Spannbereich Ø 3,0 - 16,0 mm	<b>RU25   RU40</b>	108 117	1
Adapter mit Weldonenschaft 1/2" für Bohrfutter Art.-Nr. 108 116	<b>A10</b>	108 109	1
Kegeldorn mit MK 2 Schaft für Bohrfutter Art.-Nr. 108 117	<b>RU25</b>	108 120	1
Kegeldorn mit MK 3 Schaft für Bohrfutter Art.-Nr. 108 117	<b>RU40</b>	108 121	1
Reduzierhülse MK 3 auf MK 2	<b>RU40</b>	108 125	1
Reduzierhülse MK 3 auf MK 1	<b>RU40</b>	108 124	1

## Magnetspäneheber

Der RUKO Magnetspäneheber zieht durch seinen haftstarken Magneten Metallspäne an. Durch Zurückziehen des Magneten im Gehäuse werden die Späne wieder fallen gelassen. Ideal zum Entfernen der Späne an schwer zugänglichen Stellen.

Verpackung: Kunststoff

		
Magnetspäneheber Länge 400.0 mm	108 202	1





09













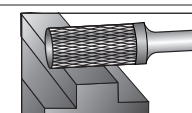

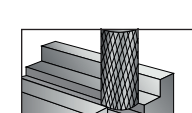

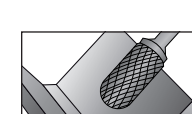







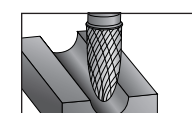

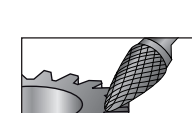

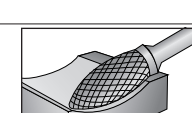

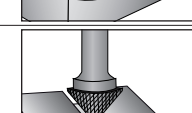
# FRÄSSTIFTE

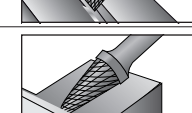
Typen- und Anwendungsübersicht	224 – 226
Form A Zylinder (ZYA) HM + TiCN – ohne Stirnverzahnung	228
Form B Zylinder (ZYAS) HM + TiCN – mit Stirnverzahnung	228
Form C Walzenrund (WRC) HM + TiCN	229
Form D Kugel (KUD) HM + TiCN	229
Form E Tropfen (TRE) HM	230
Form F Rundbogen (RBF) HM + TiCN	230
Form G Spitzbogen (SPG) HM + TiCN	231
Form H Flamme (FLH) HM	232
Form K Kegel 90° (KSK) HM	232
Form L Rundkegel (KEL) HM	232
Form M Spitzkegel (SKM) HM + TiCN	233
Form N Winkel (WKN) HM	233
Hartmetall-Frässtift-Module HM + TiCN	234
Hartmetall-Frässtift-Sätze HM + TiCN	234 – 235
Drehzahlrichtwerte für Hartmetallfrässtifte – nach Durchmesser	235
Druckluftschleifer – kurz	236
Druckluftschleifer – 90° Winkelkopf	237
Druckluftschleifer – 115° Winkelkopf	238
Druckluftschleifer – lang	239
Druckluftschleifer und Frässtifte-Satz	240
Zubehör für Druckluftschleifer-Satz	240
Drehzahlrichtwerte für Hartmetallfrässtifte – nach Werkstoffgruppen	241

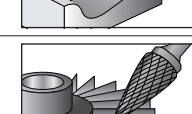
# Typen- und Anwendungsübersicht

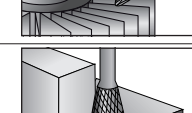
	Spitze	Anwendung	Beschreibung	Ø mm	Art.-Nr.	Seite/n
			Form A Zylinder (ZYA) – ohne Stirnverzahnung	3,0 – 16,0	116 xxx TC 116 xxx	228
			Form B Zylinder (ZYAS) – mit Stirnverzahnung	3,0 – 16,0 6,0 / 12,0	116 xxx TC 116 xxx 116 xxx A	228
			Form C Walzenrund (WRC)	3,0 – 16,0 6,0 / 12,0	116 xxx TC 116 xxx 116 xxx A	229
			Form D Kugel (KUD)	3,0 – 16,0 6,0 / 12,0	116 xxx TC 116 xxx 116 xxx A	229
			Form E Tropfen (TRE)	3,0 – 16,0	116 xxx	230
			Form F Rundbogen (RBF)	3,0 – 16,0 6,0 / 12,0	116 xxx TC 116 xxx 116 xxx A	230
			Form G Spitzbogen (SPG)	3,0 – 16,0 6,0 / 12,0	116 xxx TC 116 xxx 116 xxx A	231
			Form H Flamme (FLH)	3,0 – 16,0	116 xxx	231
			Form K Kegel 90° (KSK)	3,0 – 16,0	116 xxx	232
			Form L Rundkegel (KEL)	3,0 – 16,0 6,0 / 10,0 / 12,0	116 xxx 116 xxx A	232
			Form M Spitzkegel (SKM)	6,0 – 16 3,0 – 16,0	116 xxx TC 116 xxx	233
			Form N Winkel (WKN)	3,0 – 16,0	116 xxx	233



# Typenübersicht

	Beschreibung	Drehzahl U/min	Art.-Nr.	Seite/n
	<p>Druckluftschleifer inklusive Anschlussadapter zum Entgraten und Polieren und zur Schweißnahtbearbeitung – kurz</p>	25.000	116 100 L	236
	<p>Druckluftschleifer inklusive Anschlussadapter zum Entgraten und Polieren und zur Schweißnahtbearbeitung – 90° Winkelkopf</p>	20.000	116 110 L	237
	<p>Druckluftschleifer inklusive Anschlussadapter zum Entgraten und Polieren und zur Schweißnahtbearbeitung – 115° Winkelkopf</p>	20.000	116 120 L	238
	<p>Druckluftschleifer inklusive Anschlussadapter zum Entgraten und Polieren und zur Schweißnahtbearbeitung – lang</p>	25.000	116 130 L	239

09





## Hartmetall-Frässtifte Form A Zylinder (ZYA) – ohne Stirnverzahnung

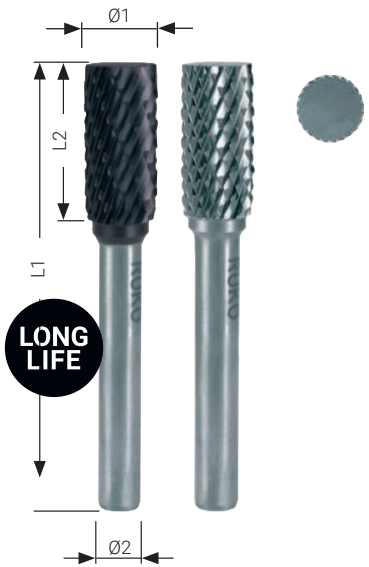

Verpackung: Kunststoff

Ø mm	L2 mm	L1 mm	L2 mm	TC / HM TiCN, CT 4		TC / HM CT 4	
3.0	14.0	38.0	3.0	—	1	116 046	1
6.0	18.0	58.0	6.0	116 010 TC	1	116 010	1
8.0	18.0	60.0	6.0	116 011 TC	1	116 011	1
10.0	20.0	60.0	6.0	116 012 TC	1	116 012	1
12.0	25.0	65.0	6.0	116 013 TC	1	116 013	1
16.0	25.0	65.0	6.0	116 014 TC	1	116 014	1

09

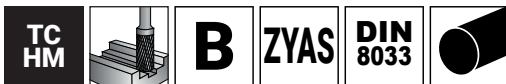

## Hartmetall-Frässtifte Form B Zylinder (ZYAS) – mit Stirnverzahnung

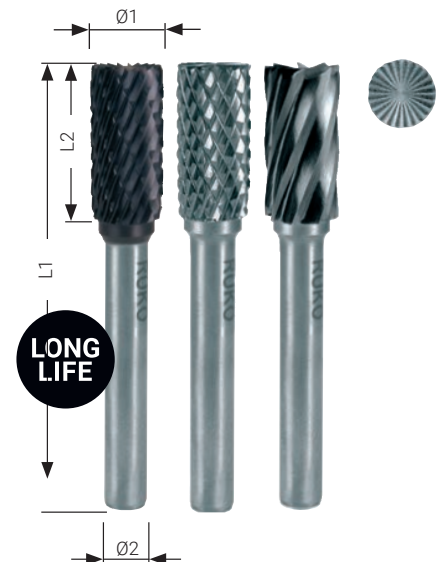
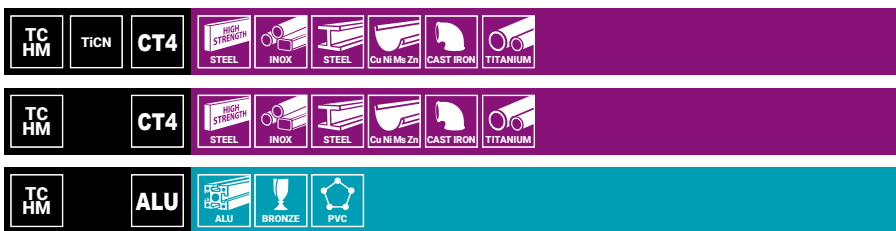

Verpackung: Kunststoff

Ø mm	L2 mm	L1 mm	L2 mm	TC / HM TiCN, CT 4		TC / HM CT 4		TC / HM ALU	
3.0	14.0	38.0	3.0	—	1	116 047	1	—	—
6.0	18.0	58.0	6.0	116 015 TC	1	116 015	1	116 015 A	1
8.0	18.0	60.0	6.0	116 016 TC	1	116 016	1	—	—
10.0	20.0	60.0	6.0	116 017 TC	1	116 017	1	—	—
12.0	25.0	65.0	6.0	116 018 TC	1	116 018	1	116 018 A	1
16.0	25.0	65.0	6.0	116 019 TC	1	116 019	1	—	—



## Hartmetall-Frässtifte Form C Walzenrund (WRC)

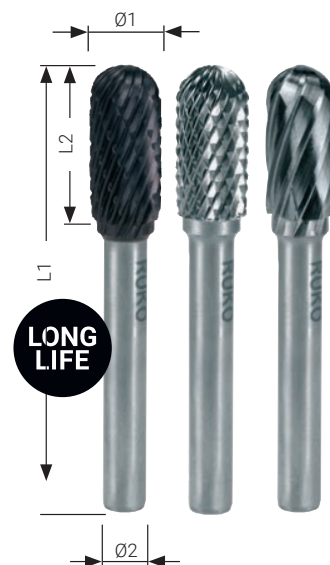
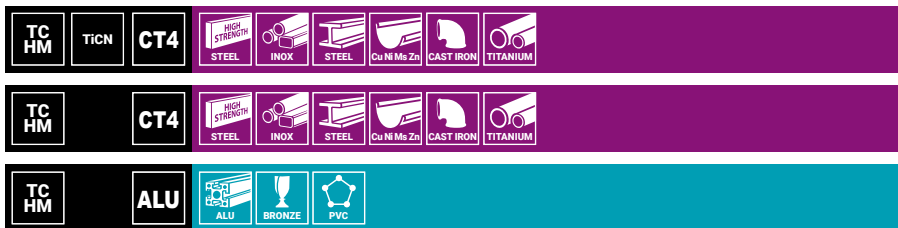

Verpackung: Kunststoff

Ø mm	L2 mm	L1 mm	L2 mm	TC / HM	📦	TC / HM	📦	TC / HM	📦
				TiCN, CT 4		CT 4		ALU	
3.0	14.0	43.0	3.0	—		116 048	1	—	
6.0	16.0	56.0	6.0	116 020 TC	1	116 020	1	116 020 A	1
8.0	16.0	56.0	6.0	116 021 TC	1	116 021	1	—	
10.0	20.0	60.0	6.0	116 022 TC	1	116 022	1	—	
12.0	25.0	65.0	6.0	116 023 TC	1	116 023	1	116 023 A	1
16.0	25.0	65.0	6.0	116 024 TC	1	116 024	1	—	



## Hartmetall-Frässtifte Form D Kugel (KUD)

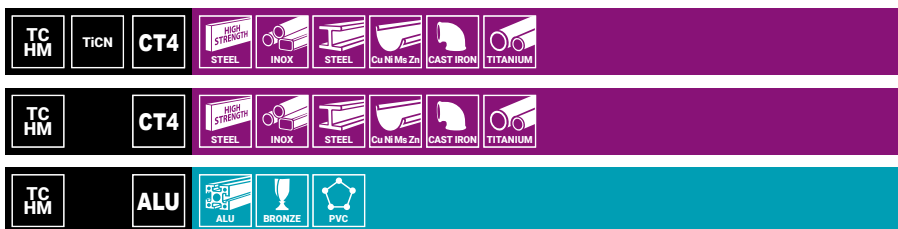

Verpackung: Kunststoff

Ø mm	L2 mm	L1 mm	L2 mm	TC / HM	📦	TC / HM	📦	TC / HM	📦
				TiCN, CT 4		CT 4		ALU	
3.0	2.7	33.0	3.0	—		116 052	1	—	
6.0	5.4	45.0	6.0	116 041 TC	1	116 041	1	116 041 A	1
8.0	7.2	47.0	6.0	116 042 TC	1	116 042	1	—	
10.0	9.0	49.0	6.0	116 043 TC	1	116 043	1	—	
12.0	11.0	51.0	6.0	116 044 TC	1	116 044	1	116 044 A	1
16.0	14.4	54.0	6.0	116 045 TC	1	116 045	1	—	



## Hartmetall-Frässtifte Form E Tropfen (TRE)



Verpackung: Kunststoff

Ø mm	L2 mm	L1 mm	L2 mm	TC / HM CT 4	
3.0	7.0	37.0	3.0	116 210	1
6.0	10.0	50.0	6.0	116 211	1
8.0	13.0	53.0	6.0	116 212	1
10.0	16.0	56.0	6.0	116 213	1
12.0	20.0	60.0	6.0	116 214	1
16.0	25.0	65.0	6.0	116 215	1

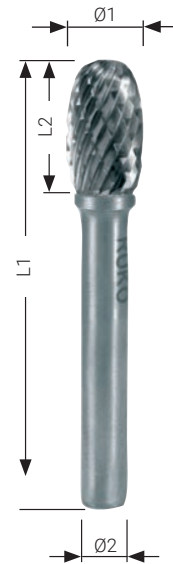

09



## Hartmetall-Frässtifte Form F Rundbogen (RBF)

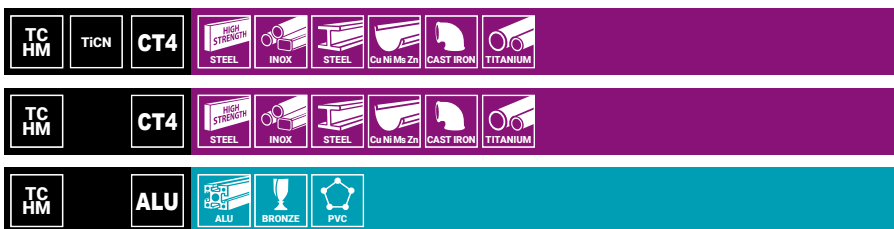

Verpackung: Kunststoff

Ø mm	L2 mm	L1 mm	L2 mm	TC / HM TiCN, CT 4	
3.0	7.0	37.0	3.0	—	
6.0	18.0	58.0	6.0	116 030 TC	1
8.0	18.0	60.0	6.0	116 031 TC	1
10.0	20.0	60.0	6.0	116 032 TC	1
12.0	25.0	65.0	6.0	116 033 TC	1
16.0	30.0	70.0	6.0	116 034 TC	1



TC / HM CT 4	
116 050	1
116 030	1
116 031	1
116 032	1
116 033	1
116 034	1

TC / HM ALU	
—	
116 030 A	1
—	
—	
116 033 A	1
—	





## Hartmetall-Frässtifte Form G Spitzbogen (SPG)

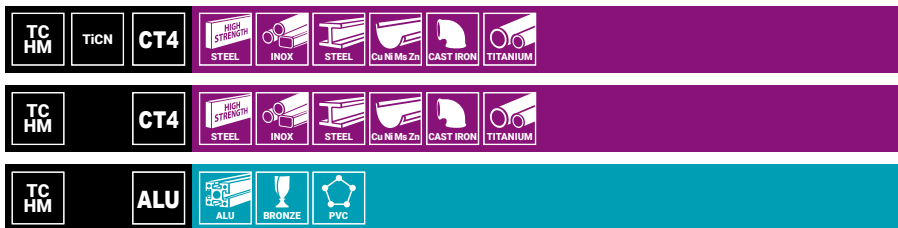

Verpackung: Kunststoff

Ø mm	L2 mm	L1 mm	L2 mm	TC / HM TiCN, CT 4	
3.0	13.0	38.0	3.0	—	
6.0	18.0	58.0	6.0	116 025 TC	1
8.0	18.0	60.0	6.0	116 026 TC	1
10.0	20.0	60.0	6.0	116 027 TC	1
12.0	25.0	65.0	6.0	116 028 TC	1
16.0	25.0	70.0	6.0	116 029 TC	1

TC / HM CT 4	
116 049	1
116 025	1
116 026	1
116 027	1
116 028	1
116 029	1

TC / HM ALU	
—	
116 025 A	1
—	
—	
116 028 A	1
—	



## Hartmetall-Frässtifte Form H Flamme (FLH)

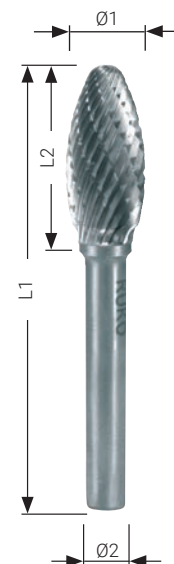

Verpackung: Kunststoff

Ø mm	L2 mm	L1 mm	L2 mm	TC / HM CT 4	
3.0	14.0	38.0	3.0	116 216	1
6.0	13.0	50.0	6.0	116 217	1
8.0	20.0	65.0	6.0	116 218	1
10.0	20.0	65.0	6.0	116 219	1
12.0	30.0	75.0	6.0	116 220	1
16.0	35.0	80.0	6.0	116 221	1





## Hartmetall-Frässtifte Form K Kegel 90° (KSK)



Verpackung: Kunststoff

Ø mm	L2 mm	L1 mm	L2 mm	TC / HM CT 4	
3.0	3.0	38.0	3.0	116 227	1
6.0	5.0	50.0	6.0	116 228	1
10.0	5.0	50.0	6.0	116 229	1
12.0	8.0	53.0	6.0	116 230	1
16.0	8.0	53.0	6.0	116 231	1

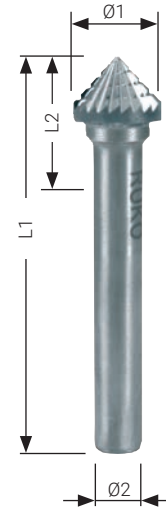

09



## Hartmetall-Frässtifte Form L Rundkegel (KEL)



Verpackung: Kunststoff

Ø mm	L2 mm	L1 mm	L2 mm	TC / HM CT 4		TC / HM ALU	
3.0	12.0	38.0	3.0	116 232	1		
6.0	18.0	52.0	6.0	116 233	1	116 233 A	1
8.0	20.0	60.0	6.0	116 234	1		
10.0	20.0	60.0	6.0	116 235	1	116 235 A	1
12.0	30.0	70.0	6.0	116 236	1	116 236 A	1
16.0	30.0	70.0	6.0	116 237	1		

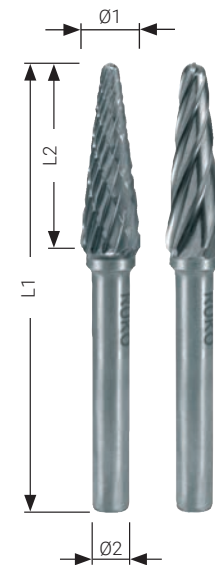



## Hartmetall-Frässtifte Form M Spitzkegel (SKM)



Verpackung: Kunststoff

Ø mm	L2 mm	L1 mm	L2 mm	TC / HM TiCN, CT 4		TC / HM CT 4	
3.0	11.0	41.0	3.0			116 051	1
6.0	18.0	58.0	6.0	116 035 TC	1	116 035	1
8.0	20.0	60.0	6.0	116 036 TC	1	116 036	1
10.0	20.0	60.0	6.0	116 037 TC	1	116 037	1
12.0	25.0	65.0	6.0	116 038 TC	1	116 038	1
16.0	25.0	65.0	6.0	116 039 TC	1	116 039	1



## Hartmetall-Frässtifte Form N Winkel (WKN)



Verpackung: Kunststoff

Ø mm	L2 mm	L1 mm	L2 mm	TC / HM CT 4	
3.0	7,0	37,0	3,0	116 238	1
6.0	7,0	47,0	6,0	116 239	1
10.0	13,0	53,0	6,0	116 240	1
12.0	13,0	53,0	6,0	116 241	1
16.0	13,0	53,0	6,0	116 242	1

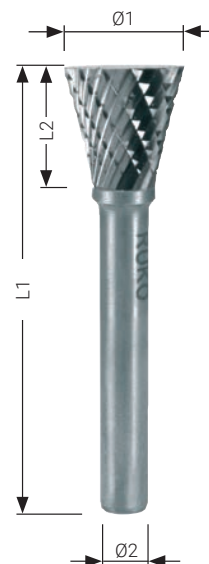



## Hartmetall-Frässtift-Module



116 008 TC



		TC / HM TiCN, CT 4	TC / HM CT 4
<b>35</b> tfg./pcs.	<p>Hartmetall-Frässtifte-Modul je 1x Ø D1 6.0 mm   8.0 mm   10.0 mm   12.0 mm   16.0 mm</p> <p>5 Frässtifte Form A Zylinder (ZYA) ohne Stirnverzahnung 5 Frässtifte Form B Zylinder (ZYAS) mit Stirnverzahnung 5 Frässtifte Form C Walzenrund (WRC) 5 Frässtifte Form G Spitzbogen (SPG) 5 Frässtifte Form F Rundbogen (RBF) 5 Frässtifte Form M Spitzkegel (SKM) 5 Frässtifte Form D Kugel (KUD)</p>	116 008 TC	116 008

## Hartmetall-Frässtift-Sätze



116 003 RO



		TC / HM TiCN, CT 4	TC / HM CT 4	TC / HM ALU
<b>10</b> tfg./pcs.	<p>Hartmetall-Frässtifte-Sätze</p> <p>2 x Form A Zylinder (ZYA) ohne Stirnverzahnung Ø D1 10.0 / 12.0 mm 2 x Form C Walzenrund (WRC) Ø D1 10.0 / 12.0 mm 2 x Form G Spitzbogen (SPG) Ø D1 10.0 / 12.0 mm 2 x Form F Rundbogen (RBF) Ø D1 10.0 / 12.0 mm 1 x Form M Spitzkegel (SKM) Ø D1 12.0 mm 1 x Form D Kugel (KUD) Ø D1 12.0 mm</p>	116 003 TCRO	116 003 RO	
<b>10</b> tfg./pcs.	<p>Hartmetall-Frässtift-Satz für Aluminiumanwendungen</p> <p>2 x Form B Zylinder (ZYAS) mit Stirnverzahnung Ø D1 6.0 / 12.0 mm 2 x Form C Walzenrund (WRC) Ø D1 6.0 / 12.0 mm 2 x Form G Spitzbogen (SPG) Ø D1 6.0 / 12.0 mm 2 x Form F Rundbogen (RBF) Ø D1 6.0 / 12.0 mm 2 x Form D Kugel (KUD) Ø D1 6.0 / 12.0 mm</p>			116 103 ARO

09

## Hartmetall-Frässtifte-Sätze



		TC / HM
<b>3</b> Stk./pcs.	Hartmetall-Frässtifte-Satz je 1x Ø 10.0 mm  1 Frässtift Form B, Zylinder (ZYAS) mit Stirnverzahnung 1 Frässtift Form G, Spitzbogen (SPG) 1 Frässtift Form D, Kugel (KUD)	116 001
<b>10</b> Stk./pcs.	Hartmetall-Frässtifte-Satz je 1x Ø 6.0 + 12.0 mm  2 Frässtifte Form B, Zylinder (ZYAS) mit Stirnverzahnung 2 Frässtifte Form C, Walzenrund (WRC) 2 Frässtifte Form G, Spitzbogen (SPG) 2 Frässtifte Form F, Rundbogen (RBF) 2 Frässtifte Form D, Kugel (KUD)	116 002
<b>5</b> Stk./pcs.	Hartmetall-Frässtifte-Satz je 1x Ø 10.0 mm  1 Frässtift Form B, Zylinder (ZYAS) mit Stirnverzahnung 1 Frässtift Form C, Walzenrund (WRC) 1 Frässtift Form G, Spitzbogen (SPG) 1 Frässtift Form F, Rundbogen (RBF) 1 Frässtift Form D, Kugel (KUD)	116 004
<b>5</b> Stk./pcs.	Hartmetall-Frässtifte-Satz je 1x Ø 12.0 mm  1 Frässtift Form B, Zylinder (ZYAS) mit Stirnverzahnung 1 Frässtift Form C, Walzenrund (WRC) 1 Frässtift Form G, Spitzbogen (SPG) 1 Frässtift Form F, Rundbogen (RBF) 1 Frässtift Form D, Kugel (KUD)	116 005



## Drehzahlrichtwerte für Hartmetallfrässtifte – nach Durchmesser

Schnittgeschwindigkeit V <sub>c</sub> = m/min	250	300	350	400	450	500	600	900
Ø mm	U/min	U/min	U/min	U/min	U/min	U/min	U/min	U/min
3.0	27.000	32.000	37.000	44.000	48.000	54.000	64.000	95.000
4.0	20.000	24.000	28.000	32.000	36.000	40.000	48.000	72.000
6.0	13.000	16.000	19.000	21.000	24.000	27.000	32.000	48.000
8.0	10.000	12.000	14.000	16.000	18.000	20.000	24.000	36.000
10.0	8.000	10.000	11.000	13.000	14.000	16.000	19.000	29.000
12.0	7.000	8.000	9.000	11.000	12.000	13.000	16.000	24.000
16.0	5.000	6.000	7.000	8.000	9.000	10.000	12.000	18.000

# Druckluftschleifer inklusive Anschlussadapter zum Entgraten und Polieren und zur Schweißnahtbearbeitung – kurz

Der RUKO Druckluftschleifer verfügt über einen gummierten, rutschfesten Handgriff, der Vibrationen dämpft und den Anwender vor dem Abrutschen während des Arbeitens schützt. Die Drehzahl ist durch einen Regler oben am Werkzeug einstellbar. Er verfügt über eine Werkzeugaufnahme aus gehärtetem Stahl. Die Abluft wird durch den Handgriff mittels 360° Rotationsprinzip nach hinten abgeführt.

Der RUKO Druckluftschleifer verfügt über einen integrierten Luftfilter, der den Motor vor Verunreinigungen schützt, die mit der Druckluft ins Innere gelangen könnten.



<b>2</b> Stk./pcs.	Druckluftschleifer (kurz)	116 100 L

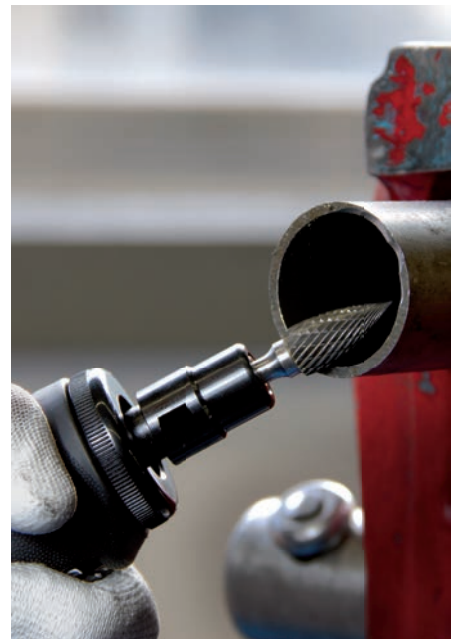

**09**

	Drehzahl: 25.000 U/min		Schlauchgröße: 3/8"
	Werkzeugaufnahme: Ø 6.0 mm		Lautstärke: 77 dB(A)
	Ø - Luftverbrauch: 113 L/Min		Gesamtlänge: 157.0 mm
	Druckluftaufnahme: G 1/4"		Gewicht: 0.57 kg
	Luftdruck: 6.2 bar		

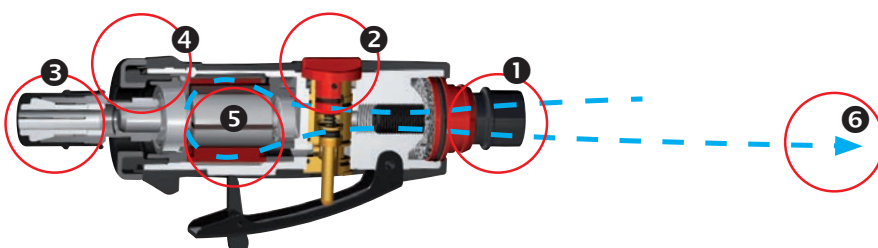

- ❶ Luftfilter
- ❷ Drehzahlregler
- ❸ Aufnahme / HMe aus gehärtetem Stahl
- ❹ Gummierter, rutschfester Handgriff
- ❺ Leistungsstarker Lamellenmotor
- ❻ Abluftführung durch den Handgriff mittels 360° Rotationsprinzip

## Druckluftschleifer inklusive Anschlussadapter zum Entgraten und Polieren und zur Schweißnahtbearbeitung – 90° Winkelkopf

Der RUKO Druckluftschleifer verfügt über einen gummierten, rutschfesten Handgriff, der Vibrationen dämpft und den Anwender vor dem Abrutschen während des Arbeitens schützt. Die Drehzahl ist durch einen Regler oben am Werkzeug einstellbar. Er verfügt über eine Werkzeugaufnahme aus gehärtetem Stahl. Die Abluft wird durch den Handgriff mittels 360° Rotationsprinzip nach hinten abgeführt.

Der RUKO Druckluftschleifer verfügt über einen integrierten Luftfilter, der den Motor vor Verunreinigungen schützt, die mit der Druckluft ins Innere gelangen könnten. Der 90° Winkelkopf erleichtert das Arbeiten an engen und schwer zugänglichen Stellen.



<b>2</b> tkt./pcs.	Druckluftschleifer (90°)	116 110 L

	Drehzahl: 20.000 U/min		Schlauchgröße: 3/8"
	Werkzeugaufnahme: Ø 6.0 mm		Lautstärke: 77 dB(A)
	Ø - Luftverbrauch: 113 L/Min		Gesamtlänge: 162.0 mm
	Druckluftaufnahme: G 1/4"		Gewicht: 0.60 kg
	Luftdruck: 6.2 bar		

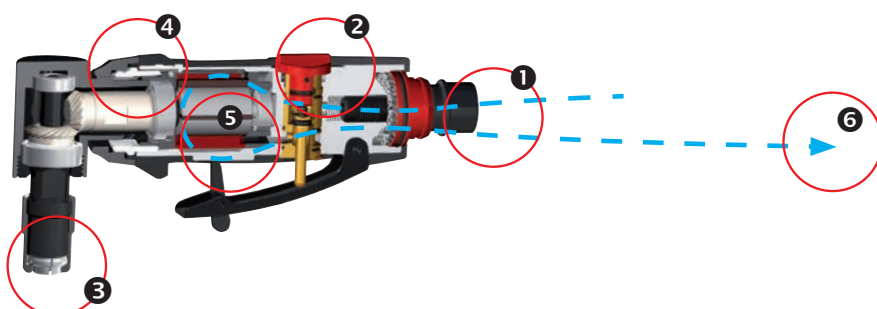
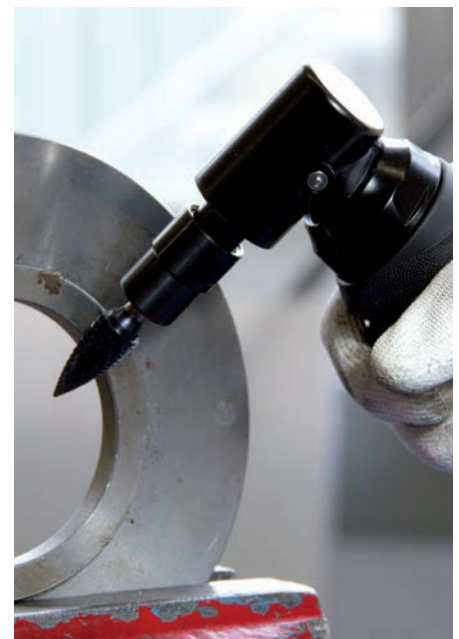

- 1 Luftfilter
- 2 Drehzahlregler
- 3 Aufnahme / HMe aus gehärtetem Stahl
- 4 Gummierter, rutschfester Handgriff
- 5 Leistungsstarker Lamellenmotor
- 6 Abluftführung durch den Handgriff mittels 360° Rotationsprinzip

## Druckluftschleifer inklusive Anschlussadapter zum Entgraten und Polieren und zur Schweißnahtbearbeitung – 115° Winkelkopf

Der RUKO Druckluftschleifer verfügt über einen gummierten, rutschfesten Handgriff, der Vibrationen dämpft und den Anwender vor dem Abrutschen während des Arbeitens schützt. Die Drehzahl ist durch einen Regler oben am Werkzeug einstellbar. Er verfügt über eine Werkzeugaufnahme aus gehärtetem Stahl. Die Abluft wird durch den Handgriff mittels 360° Rotationsprinzip nach hinten abgeführt.

Der RUKO Druckluftschleifer verfügt über einen integrierten Luftfilter, der den Motor vor Verunreinigungen schützt, die mit der Druckluft ins Innere gelangen könnten. Der 115° Winkelkopf erleichtert das Arbeiten an engen und schwer zugänglichen Stellen.



<b>2</b> Stk./pcs.	Druckluftschleifer (115°)	116 120 L

	Drehzahl: 20.000 U/min		Schlauchgröße: 3/8"
	Werkzeugaufnahme: Ø 6.0 mm		Lautstärke: 77 dB(A)
	Ø - Luftverbrauch: 113 L/Min		Gesamtlänge: 201.0 mm
	Druckluftaufnahme: G 1/4"		Gewicht: 0.70 kg
	Luftdruck: 6.2 bar		

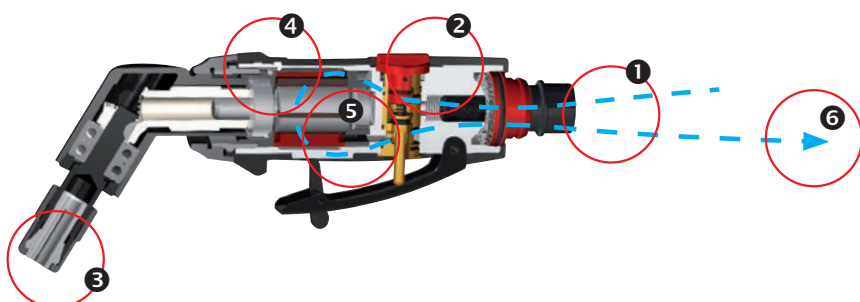

- ❶ Luftfilter
- ❷ Drehzahlregler
- ❸ Aufnahme / HMe aus gehärtetem Stahl
- ❹ Gummierter, rutschfester Handgriff
- ❺ Leistungsstarker Lamellenmotor
- ❻ Abluftführung durch den Handgriff mittels 360° Rotationsprinzip



## Druckluftschleifer inklusive Anschlussadapter zum Entgraten und Polieren und zur Schweißnahtbearbeitung – lang

Der RUKO Druckluftschleifer verfügt über einen gummierten, rutschfesten Handgriff, der Vibrationen dämpft und den Anwender vor dem Abrutschen während des Arbeitens schützt. Die Drehzahl ist durch einen Regler oben am Werkzeug einstellbar. Er verfügt über eine Werkzeugaufnahme aus gehärtetem Stahl. Die Abluft wird durch den Handgriff mittels 360° Rotationsprinzip nach hinten abgeführt.

Der RUKO Druckluftschleifer verfügt über einen integrierten Luftfilter, der den Motor vor Verunreinigungen schützt, die mit der Druckluft ins Innere gelangen könnten. Die Werkzeugverlängerung ermöglicht das Arbeiten an engen, schwer zugänglichen und tief liegenden Stellen.



<b>2</b> Stk./pcs.	Druckluftschleifer (lang)	116 130 L

	Drehzahl: 25.000 U/min		Schlauchgröße: 3/8"
	Werkzeugaufnahme: Ø 6.0 mm		Lautstärke: 77 dB(A)
	Ø - Luftverbrauch: 113 L/Min		Gesamtlänge: 257.0 mm
	Druckluftaufnahme: G 1/4"		Gewicht: 0.90 kg
	Luftdruck: 6.2 bar		

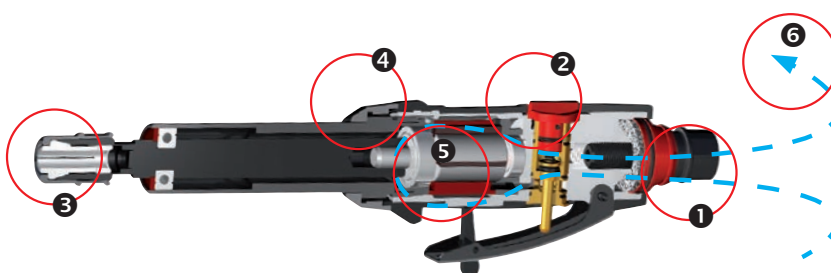

- ❶ Luftfilter
- ❷ Drehzahlregler
- ❸ Aufnahme aus gehärtetem Stahl
- ❹ Gummierter, rutschfester Handgriff
- ❺ Leistungsstarker Lamellenmotor
- ❻ Ablufführung durch den Handgriff mittels 360° Rotationsprinzip



## Druckluftschleifer und Frässtifte-Satz



		TC / HM CT 4
<b>12</b> tlg./pcs.	1x Druckluftschleifer kurz 1x Kupplungsstecker für Druckluftschleifer 1x Frässtifte-Satz in Mini-Box 10 tlg.   Art.-Nr. 116 002	116 100
<b>5</b> tlg./pcs.	1x Druckluftschleifer kurz 1x Kupplungsstecker für Druckluftschleifer 1x Frässtifte-Satz in Mini-Box 3 tlg.   Art.-Nr. 116 001	116 113



116 100

## Zubehör für Druckluftschleifer

Verpackung: Kunststoff







<b>09</b>	Ersatzrotor für Druckluftschleifer	116 100-1	1
	Kupplungsstecker, Nennweite 7.2 mm mit Außengewinde G 1/4"	116 101 L	1
	Spannzange 3.0 mm für Druckluftschleifer	116 121	1
	Spannzange 1/4" für Druckluftschleifer	116 119	1



116 101 L

# Drehzahlrichtwerte für Hartmetallfrässtifte

## – nach Werkstoffgruppen

Werkstoffgruppen		Bearbeitungsfall	Schnittgeschwindigkeit
Stahl, Stahlguss 	Ungehärtete, nicht vergütete Stähle bis 1200 N/mm <sup>2</sup> (< 38 HRC)	Baustähle, Kohlenstoffstähle, Werkzeugstähle, unlegierte Stähle, Einsatzstähle, Stahlguss	Grobes Zerspanen = hoher Materialabtrag 250 - 350 m/min
	Gehärtete, vergütete Stähle über 1200 N/mm <sup>2</sup> (> 38 HRC)	Werkzeugstähle, Vergütungsstähle, legierte Stähle, Stahlguss	250 - 350 m/min
Edelstahl 	Rost- und säurebeständige Stähle	Austenitische und ferritische Edelstähle	Grobes Zerspanen = hoher Materialabtrag 250 - 350 m/min
NE-Metalle   	Weiche NE-Metalle, Buntmetalle	Alu-Legierungen, Messing, Kupfer, Zink	Grobes Zerspanen = hoher Materialabtrag 600 - 900 m/min
	Harte NE-Metalle	Bronze, Titan/Titanlegierungen, harte Alu-Legierungen (hoher Si-Anteil)	250 - 350 m/min
	Hochwarmfeste Werkstoffe	Nickelbasis- und Kobaltbasislegierungen (Triebwerk- und Turbinenbau)	300 - 450 m/min
Gusseisen 	Graues Gusseisen, weißes Gusseisen	Gusseisen mit Lamellengraphit, mit Kugelgraphit/Sphäroguss, weißer Temperguss, schwarzer Temperguss	Grobes Zerspanen = hoher Materialabtrag 600 - 900 m/min
Kunststoffe, andere Werkstoffe 	Faserverstärkte Kunststoffe, thermoplastische Kunststoffe, Hartgummi	Grobes Zerspanen = hoher Materialabtrag	500 - 1.100 m/min
		Feines Zerspanen = geringer Materialabtrag	



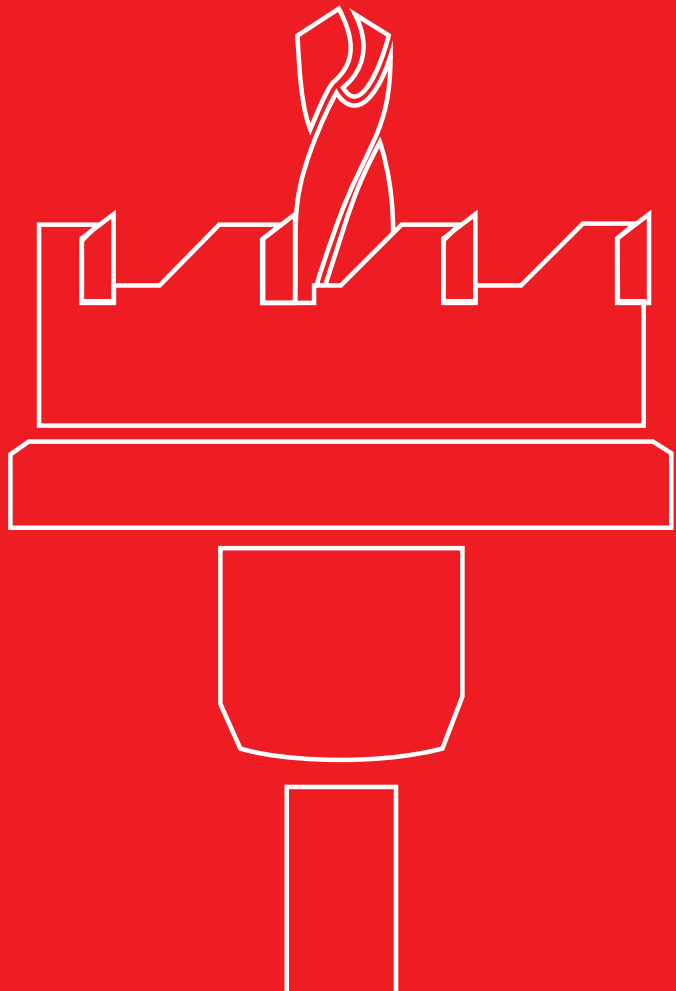



















10



# LOCHSÄGEN

Typen- und Anwendungsübersicht	244 – 245
Lochsägen HSS + Zubehör	246
Hartmetall Mehrbereichslochsäge + Zubehör	247
Hartmetall-Lochsägen Flachschnitt + Zubehör	248 – 249
Bimetall-Lochsägen HSSE-Co 8 mit Feinverzahnung	250
Bimetall-Lochsägen HSS mit variabler Zahnung	251
Bimetall-Lochsägen-Sätze HSSE-Co 8 mit Feinverzahnung + HSS mit variabler Zahnung	252
Aufnahmehalter inklusive Führungsbohrer für Bimetall-Lochsägen HSS und HSSE-Co 8	254
Zubehör für Bimetall-Lochsägen HSS und HSSE-Co 8	254
Aufnahmehalter für Mehrbereichslochsägen mit Gewindeaufnahme M18 x 6 P1,5	255
Adapter für Mehrbereichslochsägen mit Gewindeaufnahme M18 x 6 P1,5	255
Drehzahlrichtwerte – für Hartmetall-Lochsägen	256
Drehzahlrichtwerte – für Bimetall-Lochsägen HSS / HSSE-Co 8	257

# Typen- und Anwendungsübersicht

	Oberfläche	Schneiden	Schneidenwinkel	Schnitttiefe	Materialstärke	Schaft	Ø mm	Art.-Nr.	Seite
	Blank	HSS					12,0 - 80,0	128 xxx	246
	Blank	TC HM					15,0 - 100,0	113 xxx	247
	Blank	TC HM					16,0 - 120,0	105 xxx	248 – 249
		HSSE Co8					14,0 - 210,0	126 xxx	250
		HSS					14,0 - 210,0	106 xxx	251

Baustahl < 900 N/mm <sup>2</sup>	Inox < 1100 N/mm <sup>2</sup>	Hochfester Stahl < 1300 N/mm <sup>2</sup>	Aluminium	Messing	Bronze	Kunststoffe	Guss
●			●	●	○	○	○
●	●	●	●	●	○	○	●
●	●	●	●	●	○	○	●
●	●		●	●	○	○	
●			●	●	○	○	

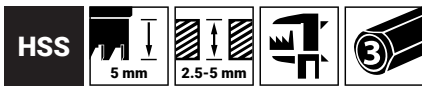

## Lochsägen HSS



Inklusive Aufnahmehalter und Führungsstift.

Verpackung Karton



Ø1 mm	Ø Zoll	PG	Rohrmaße Zoll	Ø2 mm	HSS	
12.0	15/32			8.0	128 012	1
13.0				8.0	128 013	1
14.0	9/16			8.0	128 014	1
15.0				10.0	128 015	1
16.0	5/8	PG 9		10.0	128 016	1
17.0				10.0	128 017	1
18.0				10.0	128 018	1
19.0	3/4		3/8	10.0	128 019	1
20.0				10.0	128 020	1
21.0				10.0	128 021	1
22.0			1/2	10.0	128 022	1
23.0				10.0	128 023	1
24.0	15/16			10.0	128 024	1
25.0				10.0	128 025	1
26.0				10.0	128 026	1
27.0	1 1/16			10.0	128 027	1
28.0	1 3/32			10.0	128 028	1
29.0			3/4	10.0	128 029	1
30.0	1 3/16			10.0	128 030	1
31.0	1 7/32			10.0	128 031	1
32.0	1 1/4			10.0	128 032	1
33.0				10.0	128 033	1
34.0				10.0	128 034	1

Ø1 mm	Ø Zoll	PG	Rohrmaße Zoll	Ø2 mm	HSS	
35.0	1 3/8		1	10.0	128 035	1
36.0				10.0	128 036	1
37.0	1 7/16	PG 29		10.0	128 037	1
38.0	1 1/2			10.0	128 038	1
39.0				10.0	128 039	1
40.0	1 9/16			10.0	128 040	1
41.0	1 5/8			10.0	128 041	1
42.0				10.0	128 042	1
43.0	1 11/16			10.0	128 043	1
44.0	1 3/4		1 1/4	10.0	128 044	1
45.0				10.0	128 045	1
46.0				10.0	128 046	1
47.0	1 7/8	PG 36		10.0	128 047	1
48.0				10.0	128 048	1
49.0				10.0	128 049	1
50.0	1 31/32			10.0	128 050	1
55.0				12.0	128 055	1
60.0	2 3/8	PG 48		12.0	128 060	1
65.0				12.0	128 065	1
70.0	2 3/4			12.0	128 070	1
75.0				12.0	128 075	1
80.0				12.0	128 080	1



## Zubehör

Verpackung: Kunststoff

Aufnahmehalter inklusive Führungsbohrer.

für Lochsägen Ø mm	Schaft Ø mm	passend für Magnetbohrmaschine	HSS	
12.0 - 14.0	8.0	A10	128 211	1
15.0 - 34.0	10.0		128 212	1
35.0 - 50.0	10.0	RU25   RU40	128 213	1
51.0 - 100.0	12.0		128 214	1

	für Lochsägen Ø mm	HSS	
Führungsstift Ø 6.0 x 52.0 mm	12.0 - 100.0	128 215	1
Auswurfeder	Ø > 20.0	128 216	1



128 ...



128 215



128 216





# Hartmetall Mehrbereichslochsäge



Aufnahme: Gewinde M 18 x 6 P1,5

Ø 15.0 bis 30.0 mm aus einem Stück gefertigt. Komplett mit Führungsbohrer und Schlüssel.  
Ø 31.0 bis 100.0 mm Mehrbereichslochsägen ohne Aufnahmehalter.



**!** Für Hartmetall Mehrbereichslochsäge Ø 65.0 bis 100.0 mm empfehlen wir den Gebrauch von MK-Aufnahmen Artikelnr. 113 203, 108 104, 108 105.

Verpackung: Karton

Ø1 mm	Ø Zoll	Rohrmaße Zoll	Ø2 mm	TC / HM		Ø1 mm	Ø Zoll	Rohrmaße Zoll	Ø2 mm	TC / HM	
15.0	19/32		13.0	113 015	1	34.0	1 11/32		13.0 / MK 2/3	113 034	1
16.0	5/8		13.0	113 016	1	35.0	1 3/8	1	13.0 / MK 2/3	113 035	1
17.0	11/16		13.0	113 017	1	36.0	1 1/4		13.0 / MK 2/3	113 036	1
18.0	45/64		13.0	113 018	1	38.0	1 1/2		13.0 / MK 2/3	113 038	1
19.0	3/4	3/8	13.0	113 019	1	40.0	1 9/16		13.0 / MK 2/3	113 040	1
20.0	25/32		13.0	113 020	1	42.0	1 21/32		13.0 / MK 2/3	113 042	1
21.0	13/16		13.0	113 021	1	44.0	1 3/4	1 1/4	13.0 / MK 2/3	113 044	1
22.0	7/8	1/2	13.0	113 022	1	45.0	-		13.0 / MK 2/3	113 045	1
23.0	29/32		13.0	113 023	1	50.0	1 31/32		13.0 / MK 2/3	113 050	1
24.0	15/16		13.0	113 024	1	55.0	2 11/64		13.0 / MK 2/3	113 055	1
25.0	1		13.0	113 025	1	60.0	2 3/8		13.0 / MK 2/3	113 060	1
26.0	1 1/32		13.0	113 026	1	65.0	2 9/16		13.0 / MK 2/3	113 065	1
27.0	1 1/16		13.0	113 027	1	68.0	2 11/16		13.0 / MK 2/3	113 068	1
28.0	1 3/32		13.0	113 028	1	70.0	2 3/4		13.0 / MK 2/3	113 070	1
29.0	1 1/8	3/4	13.0	113 029	1	75.0	2 61/64		13.0 / MK 2/3	113 075	1
30.0	1 3/16		13.0	113 030	1	80.0	3 5/32		13.0 / MK 2/3	113 080	1
32.0	1 1/4		13.0 / MK 2/3	113 032	1	100.0	3 15/16		13.0 / MK 2/3	113 100	1



## Zubehör

Verpackung: Kunststoff

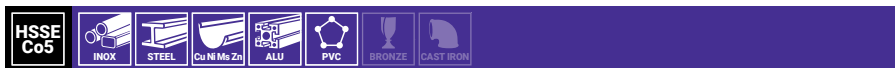

	für Lochsägen Ø mm	TC / HM		HSSE-Co 5	
Führungsstift Ø 6.0 x 80.0 mm	15.0 - 150.0	113 217	1	-	1
Führungsstift Ø 6.0 x 72.0 mm	15.0 - 150.0	-	1	113 216	1

Auswurfeder				113 218	1
-------------	--	--	--	---------	---

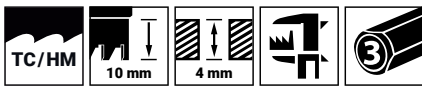

# Hartmetall-Lochsägen Flachschnitt



Lochsäge und Aufnahmehalter aus einem Stück gefertigt.  
Inklusive Führungsbohrer.

Verpackung: Karton



Ø1 mm	Ø Zoll	M + PG	Rohrmaße Zoll	Ø2 mm	TC / HM	
16.0	5/8	~ PG 9		10.0	105 016	1
16.5	-	M 16		10.0	105 165	1
17.0	11/16			10.0	105 017	1
18.0	45/64			10.0	105 018	1
18.6	47/64	PG 11		10.0	105 186	1
19.0	3/4		3/8	10.0	105 019	1
20.0	25/32			10.0	105 020	1
20.4	-	M 20 / PG 13.5		10.0	105 204	1
21.0	13/16			10.0	105 021	1
22.0	7/8		1/2	10.0	105 022	1
22.5	-	PG 16		10.0	105 225	1
23.0	29/32			10.0	105 023	1
24.0	15/16			10.0	105 024	1
25.0	1"			10.0	105 025	1
25.5	-	M 25		10.0	105 255	1
26.0	1 1/32			10.0	105 026	1
27.0	1 1/16			10.0	105 027	1
28.0	1 3/32			10.0	105 028	1
28.3	1 1/8	PG 21		10.0	105 283	1
29.0	1 1/8		3/4	10.0	105 029	1
30.0	1 3/16			10.0	105 030	1
32.0	1 1/4			10.0	105 032	1
32.5	-	M 32		10.0	105 325	1
34.0	1 11/32			10.0	105 034	1
35.0	1 3/8		1	10.0	105 035	1
36.0	1 1/4			10.0	105 036	1
37.0	1 7/16	PG 29		10.0	105 037	1
38.0	1 1/2			10.0	105 038	1

Ø1 mm	Ø Zoll	M + PG	Rohrmaße Zoll	Ø2 mm	TC / HM	
40.0	1 9/16			10.0	105 040	1
40.5	-	M 40		10.0	105 405	1
41.0	1 5/8			10.0	105 041	1
42.0	1 21/32			10.0	105 042	1
43.0	1 11/16			10.0	105 043	1
44.0	1 3/4		1 1/4	10.0	105 044	1
45.0	1 25/32			10.0	105 045	1
48.0	1 29/32			10.0	105 048	1
50.0	1 31/32			10.0	105 050	1
50.5	-	M 50		10.0	105 505	1
51.0	2		1 1/2	13.0	105 051	1
52.0	2 1/16			13.0	105 052	1
54.0	2 1/8	PG 42		13.0	105 054	1
55.0	2 11/64			13.0	105 055	1
57.0	2 1/4			13.0	105 057	1
60.0	2 3/8	~ PG 48		13.0	105 060	1
63.5	2 1/2	M 63	2	13.0	105 635	1
65.0	2 9/16			13.0	105 065	1
68.0	2 11/16			13.0	105 068	1
70.0	2 3/4			13.0	105 070	1
75.0	2 61/64			13.0	105 075	1
80.0	3 5/32			13.0	105 080	1
85.0	3 11/32			13.0	105 085	1
90.0	3 35/64			13.0	105 090	1
95.0	3 3/4			13.0	105 095	1
100.0	3 15/16			13.0	105 100	1
110.0	4 11/32			13.0	105 110	1
120.0	4 23/32			13.0	105 120	1



		HSSE-Co 5
<b>5</b> tlg./pcs.	Hartmetall-Lochsägen Satz Ø 20.0   22.0   25.0   32.0   35.0 mm + 1 Schneidpaste 40 ml   Artikel-Nr. 101 021 + 1 Führungsbohrer 6.0 mm HSSE-Co 5 Artikel-Nr. 105 170	105 300
<b>4</b> tlg./pcs.	Hartmetall-Lochsägen Satz Ø 16.5   20.4   25.5   32.5 mm + 1 Schneidpaste 40 ml   Artikel-Nr. 101 021 + 1 Führungsbohrer 6.0 mm HSSE-Co 5 Artikel-Nr. 105 170	105 302



# Zubehör

Verpackung: Kunststoff

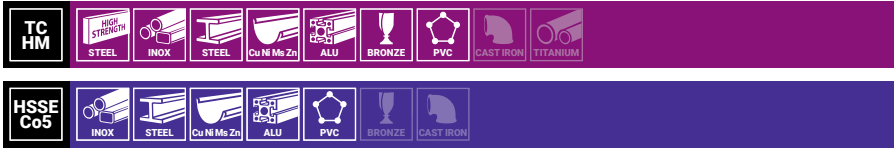

	für Lochsagen Ø mm	TC / HM		HSSE-Co 5	
Führungsstift Ø 6.0 x 52.0 mm	16.0 - 70.0	105 172	1	105 170	1
Führungsstift Ø 6.0 x 52.0 mm	75.0 - 150.0	105 173	1	105 171	1

Auswurfeder		105 174	1



## Anwendungstipp

Nach Möglichkeit keinen automatischen Vorschub verwenden, da sich sonst die Bruchgefahr erhöht. Nicht für den Schlagbohrbetrieb geeignet, mit leichtem und gleichmäßigem Anpressdruck anbohren. Pendelbewegungen vermeiden und Kühlmittel verwenden.





## Bimetall-Lochsägen HSSE-Co 8 mit Feinverzahnung

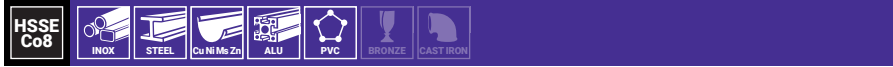

Besonders gut geeignet für Metalle. Für ruhigeren Lauf und geringeren Kraftaufwand. Erhöhung der Standzeit aufgrund geringerer Wärmeentwicklung.

Körper: Spezialstahl



**Beste Ergebnisse bis max. 5 mm.**

Verpackung: Karton

Ø1 mm	Ø Zoll	M + PG	Rohrmaße Zoll	für Aufnahmehalter	<b>HSSE-Co 8</b>	
14.0	9/16			A1 / A4 / A5	126 014	1
16.0	5/8	~ PG 9			126 016	
17.0	11/16				126 017	
19.0	3/4	~ PG 11	3/8		126 019	
20.0	25/32				126 020	
21.0	13/16	~ PG 13.5			126 021	
22.0	7/8		1/2		126 022	
24.0	15/16	~ PG 16			126 024	
25.0	1"				126 025	
27.0	1 1/16				126 027	
28.0	1 3/32				126 028	
29.0	1 1/8	~ PG 21	3/4		126 029	
30.0	1 3/16				126 030	
32.0	1 1/4				126 032	
33.0	1 5/16				126 033	
35.0	1 3/8		1		126 035	
36.0	1 1/4			126 036		
37.0	1 7/16	PG 29		126 037		
38.0	1 1/2			126 038		
40.0	1 9/16			126 040		
41.0	1 5/8			126 041		
43.0	1 11/16			126 043		
44.0	1 3/4		1 1/4	126 044		
46.0	1 13/16			126 046		
48.0	1 7/8	~ PG 36		126 048		
50.0	1 31/32			126 050		
51.0	2"		1 1/2	126 051		
52.0	2 1/16			126 052		
54.0	2 1/8	PG 42		126 054		
55.0	2 11/64			126 055		
57.0	2 1/4			126 057		
59.0	2 5/16			126 059		
60.0	2 3/8	~ PG 48		126 060		
63.0	2 15/32			126 063		
64.0	2 1/2		2	126 064		
65.0	2 9/16			126 065		
67.0	2 5/8			126 067		
68.0	2 11/16			126 068		
70.0	2 3/4			126 070		
73.0	2 7/8			126 073		
76.0	3"		2 1/2	126 076		
79.0	3 1/8			126 079		
83.0	3 1/4			126 083		
86.0	3 3/8			126 086		
89.0	3 1/2			126 089		
92.0	3 5/8		3	126 092		
95.0	3 3/4			126 095		
98.0	3 7/8			126 098		
102.0	4"			126 102		
105.0	4 1/8		3 1/2	126 105		
108.0	4 1/4			126 108		
111.0	4 3/8			126 111		
114.0	4 1/2		4	126 114		
121.0	4 3/4			126 121		
127.0	5"			126 127		
133.0	5 1/4			126 133		
140.0	5 1/2			126 140		
152.0	6"			126 152		
160.0	6 5/16			126 160		
168.0	6 5/8			126 168		
177.0	6 31/32			126 177		
210.0	8 1/4			126 200		



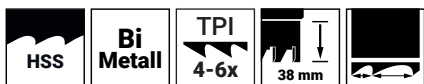

## Bimetall-Lochsägen HSS mit variabler Zahnung



Für einen gleichmäßigeren Schnitt und geringeren Kraftaufwand. Durch die geringere Vibration und Wärmeentwicklung wird eine bis zu dreifache Standzeiterhöhung erzielt.

Körper: Spezialstahl

Verpackung: Karton



**Beste Ergebnisse bis max. 5 mm.**

Ø1 mm	Ø Zoll	M + PG	Rohrmaße Zoll	für Aufnahmehalter	HSS	
14.0	9/16			A1 / A4 / A5	106 014	1
16.0	5/8	~ PG 9			106 016	
17.0	11/16				106 017	
19.0	3/4	~ PG 11	3/8		106 019	
20.0	25/32				106 020	
21.0	13/16	~ PG 13.5			106 021	
22.0	7/8		1/2		106 022	
24.0	15/16	~ PG 16			106 024	
25.0	1"				106 025	
27.0	1 1/16				106 027	
28.0	1 3/32				106 028	
29.0	1 1/8	~ PG 21	3/4		106 029	
30.0	1 3/16				106 030	
32.0	1 1/4				106 032	
33.0	1 5/16				106 033	
35.0	1 3/8		1		106 035	
36.0	1 1/4				106 036	
37.0	1 7/16	PG 29			106 037	
38.0	1 1/2			106 038		
40.0	1 9/16			106 040		
41.0	1 5/8			106 041		
43.0	1 11/16			106 043		
44.0	1 3/4		1 1/4	106 044		
46.0	1 13/16			106 046		
48.0	1 7/8	~ PG 36		106 048		
50.0	1 31/32			106 050		
51.0	2"		1 1/2	106 051		
52.0	2 1/16			106 052		
54.0	2 1/8	PG 42		106 054		
55.0	2 11/64			106 055		
57.0	2 1/4			106 057		
59.0	2 5/16			106 059		
60.0	2 3/8	~ PG 48		106 060		
63.0	2 15/32			106 063		
64.0	2 1/2		2	106 064		
65.0	2 9/16			106 065		
67.0	2 5/8			106 067		
68.0	2 11/16			106 068		
70.0	2 3/4			106 070		
73.0	2 7/8			106 073		
76.0	3"		2 1/2	106 076		
79.0	3 1/8			106 079		
83.0	3 1/4			106 083		
86.0	3 3/8			106 086		
89.0	3 1/2			106 089		
92.0	3 5/8		3	106 092		
95.0	3 3/4			106 095		
98.0	3 7/8			106 098		
102.0	4"			106 102		
105.0	4 1/8		3 1/2	106 105		
108.0	4 1/4			106 108		
111.0	4 3/8			106 111		
114.0	4 1/2		4	106 114		
121.0	4 3/4			106 121		
127.0	5"			106 127		
133.0	5 1/4			106 133		
140.0	5 1/2			106 140		
152.0	6"			106 152		
160.0	6 5/16			106 160		
168.0	6 5/8			106 168		
177.0	6 31/32			106 177		
210.0	8 1/4			106 200		



# Bimetal-Lochsägen-Sätze

## HSSE-Co 8 Feinverzahnung | HSS variabler Zahnung



		HSSE-Co 8	HSS
<b>8</b> tlg./pcs.	Sanitär 1 Bimetal-Lochsägen-Satz Ø 19.0   22.0   29.0   38.0   44.0   57.0 mm + 2 Aufnahmehalter A2 + A4	126 301	106 301
<b>11</b> tlg./pcs.	Sanitär 2 Bimetal-Lochsägen-Satz Ø 19.0   22.0   29.0   35.0   38.0   44.0   51.0   57.0   64.0 mm + 2 Aufnahmehalter A2 + A4	126 306	106 306
<b>8</b> tlg./pcs.	Elektro 1 Bimetal-Lochsägen-Satz Ø 22.0   29.0   35.0   44.0   51.0   64.0 mm + 2 Aufnahmehalter A2 + A4	126 305	106 305
<b>8</b> tlg./pcs.	Elektro 2 Bimetal-Lochsägen-Satz Ø 22.0   29.0   35.0   44.0   51.0   68.0 mm + 2 Aufnahmehalter A2 + A4	126 302	106 302
<b>12</b> tlg./pcs.	Universal Bimetal-Lochsägen-Satz Ø 19.0   22.0   25.0   29.0   35.0   38.0   44.0   51.0   57.0   64.0 mm + 2 Aufnahmehalter A2 + A4	126 303	106 303
<b>12</b> tlg./pcs.	Super Bimetal-Lochsägen-Satz Ø 22.0   25.0   32.0   35.0   41.0   44.0   51.0   54.0   60.0   68.0 mm + 2 Aufnahmehalter A2 + A4	126 304	106 304
<b>19</b> tlg./pcs.	Premium Bimetal-Lochsägen-Satz Ø 16.0   19.0   21.0   24.0   25.0   29.0   32.0   37.0   40.0   48.0   51.0   54.0   60.0   73.0   83.0 mm + 2 Aufnahmehalter A1 + A2 + 1 Führungsbohrer HSS Ø 6.35 mm x 82.0 mm + 1 Verlängerung 300.0 mm. Aufnahme für A1 + A2	126 318	106 318



106 306



126 304



106 318



## Aufnahmehalter inklusive Führungsbohrer für Bimetall-Lochsägen HSS und HSSE-Co 8



Verpackung: Karton

Lochsägen Ø mm	Aufnahmehalter Typ	Schaft Ø mm	Schaft Form	Gewinde	HSSE-Co 8	HSS	
14.0 - 30.0	A1	11.0	⬡	1/2" x 20	126 201	106 201	1
32.0 - 210.0	A2	11.0	⬡	5/8" x 18	126 202	106 202	1
14.0 - 30.0	A4	6.0	○	1/2" x 20	126 204	106 204	1
14.0 - 30.0	A5	9.5	⬡	1/2" x 20	126 210	106 210	1
32.0 - 210.0	A6	9.5	⬡	5/8" x 18	126 209	106 209	1
32.0 - 210.0	A7	10.0	SDS-Plus	5/8" x 18	126 211	106 211	1

## Zubehör für Bimetall-Lochsägen HSS und HSSE-Co 8

10

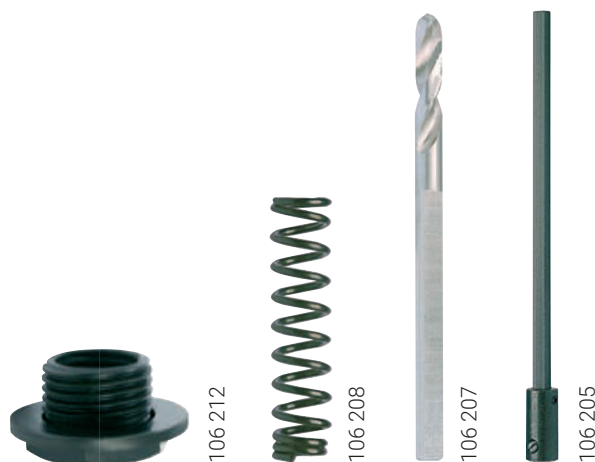

Verpackung: Kunststoff

	Aufnahmehalter Typ	HSSE-Co 5	HSS	
Adapter zur Aufnahme von HSS und HSSE-Co 8 Bimetall-Lochsägen ab Ø 32.0 bis Ø 210.0 mm	A1 / A4 / A5		106 212	1
Führungsbohrer HSS / HSSE-Co 5, geschliffen Ø 6.35 x 102.0 mm mit Kreuzanschliff nach DIN 1412 C	A4	126 207	106 207	1
Führungsbohrer HSS / HSSE-Co 5, geschliffen Ø 6.35 x 82.0 mm mit Kreuzanschliff nach DIN 1412 C	A1 / A2 / A5 / A6 / A7	126 206	106 206	1
Verlängerung 300.0 mm, Schaftform ⬡ 11.0 mm	A1 / A2	-	106 205	1
Auswurfeder	-	-	106 208	1



## Aufnahmehalter für Mehrbereichslochsägen mit Gewindeaufnahme M18 x 6 P1,5

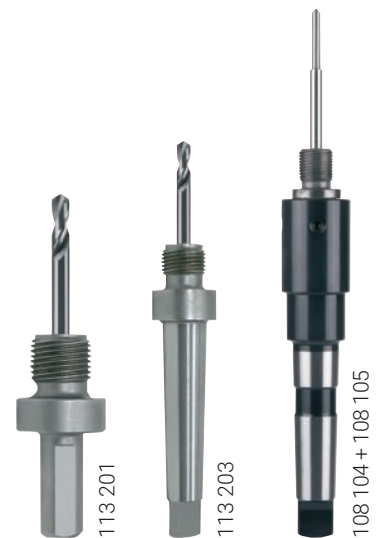

Verpackung: Kunststoff

	für Lochsägen MBL Ø mm	Schaft	passend für Magnetbohrmaschine		
Aufnahmehalter inklusive Führungsbohrer Artikel-Nr. 113 216	31.0 - 100.0	Ø 13.0 mm	A10	113 201	1
Aufnahmehalter inklusive Führungsbohrer Artikel-Nr. 113 216	31.0 - 100.0	MK 2	RU25	113 203	1
Aufnahmehalter mit Innenkühlung inklusive Adapter Art.-Nr. 108 108 und Führungsstift Art.-Nr. 108 110	31.0 - 100.0	MK 2	RU25	108 104	1
Aufnahmehalter mit Innenkühlung inklusive Adapter Art.-Nr. 108 108 und Führungsstift Art.-Nr. 108 110	31.0 - 100.0	MK 3	RU40	108 105	1

## Adapter für Mehrbereichslochsägen mit Gewindeaufnahme M18 x 6 P1,5

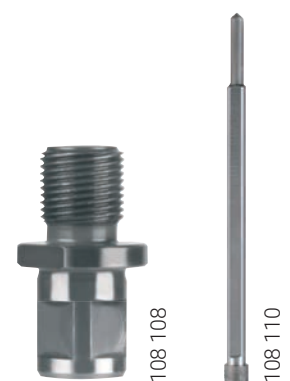

Verpackung: Kunststoff

	für Lochsägen MBL Ø mm		
Adapter mit Weldonschaft 3/4" für Mehrbereichslochsägen mit Gewindeaufnahme M18 x 6 P1,5	31.0 - 100.0	108 108	1
Auswerferstift Ø 6,35 x 118,0 mm	31.0 - 100.0	108 110	1



# Drehzahlrichtwerte – für Hartmetall-Lochsägen

Material:		Unlegierter Baustahl	Legierter Stahl	Guß-eisen	CuZn-Legierung	Aluminium-Legierung	Thermo-plaste	Duro-plaste	Holz
		bis 700 N/mm <sup>2</sup>	bis 1000 N/mm <sup>2</sup>	über 250 N/mm <sup>2</sup>		bis 11% Si			
Vc = m/min		30	20	10	60	35	30	20	15
Kühlschmierstoff:		Schneidspray	Schneidspray	Druckluft	Druckluft	Schneidspray	Wasser	Druckluft	Druckluft
Ø mm	Ø Zoll	U/min	U/min	U/min	U/min	U/min	U/min	U/min	U/min
16.0	5/8	995	697	796	1194	1194	896	796	995
16.5	-	965	676	772	1158	1158	869	772	965
17.0	11/16	937	656	749	1124	1124	843	749	937
18.0	45/64	885	619	708	1062	1062	796	708	885
18.6	47/64	856	599	685	1027	1027	770	685	856
19.0	3/4	838	587	670	1006	1006	754	670	838
20.0	25/32	796	557	637	955	955	717	637	796
20.4	13/16	781	546	624	937	937	703	624	781
21.0	13/16	758	531	607	910	910	682	607	758
22.0	7/8	724	507	579	869	869	651	579	724
22.5	57/64	708	495	566	849	849	637	566	708
23.0	29/32	692	485	554	831	831	623	554	692
24.0	15/16	663	464	531	796	796	597	531	663
25.0	1"	637	446	510	764	764	573	510	637
25.5	-	624	437	500	749	749	562	500	624
26.0	1 1/32	612	429	490	735	735	551	490	612
27.0	1 1/16	590	413	472	708	708	531	472	590
28.0	1 3/32	569	398	455	682	682	512	455	569
28.3	1 1/8	563	394	450	675	675	506	450	563
29.0	-	549	384	439	659	659	494	439	549
30.0	1 3/16	531	372	425	637	637	478	425	531
31.0	1 7/32	514	360	411	616	616	462	411	514
32.0	1 1/4	498	348	398	597	597	448	398	498
32.5	-	490	343	392	588	588	441	392	490
33.0	1 5/16	483	338	386	579	579	434	386	483
34.0	1 11/32	468	328	375	562	562	422	375	468
35.0	1 3/8	455	318	364	546	546	409	364	455
36.0	1 1/4	442	310	354	531	531	398	354	442
37.0	1 7/16	430	301	344	516	516	387	344	430
38.0	1 1/2	419	293	335	503	503	377	335	419
39.0	1 17/32	408	286	327	490	490	367	327	408
40.0	1 9/16	398	279	318	478	478	358	318	398
40.5	1 19/32	393	275	315	472	472	354	315	393
41.0	1 5/8	388	272	311	466	466	350	311	388
42.0	1 21/32	379	265	303	455	455	341	303	379
43.0	1 11/16	370	259	296	444	444	333	296	370
44.0	1 3/4	362	253	290	434	434	326	290	362
45.0	-	354	248	283	425	425	318	283	354
46.0	1 13/16	346	242	277	415	415	312	277	346
47.0	-	339	237	271	407	407	305	271	339
48.0	1 7/8	332	232	265	398	398	299	265	332
49.0	1 15/16	325	227	260	390	390	292	260	325
50.0	1 31/32	318	223	255	382	382	287	255	318
50.5	1 63/64	315	221	252	378	378	284	252	315
51.0	2"	312	219	250	375	375	281	250	312
52.0	2 1/16	306	214	245	367	367	276	245	306
53.0	2 3/32	300	210	240	361	361	270	240	300
54.0	2 1/8	295	206	236	354	354	265	236	295
55.0	2 11/64	290	203	232	347	347	261	232	290
56.0	2 13/64	284	199	227	341	341	256	227	284
57.0	2 1/4	279	196	223	335	335	251	223	279
58.0	2 9/32	275	192	220	329	329	247	220	275
59.0	2 5/16	270	189	216	324	324	243	216	270
60.0	2 3/8	265	186	212	318	318	239	212	265
63.5	2 1/2	251	176	201	301	301	226	201	251
65.0	2 9/16	245	171	196	294	294	220	196	245
70.0	2 3/4	227	159	182	273	273	205	182	227
75.0	2 61/64	212	149	170	255	255	191	170	212
80.0	3 5/32	199	139	159	239	239	179	159	199
85.0	3 11/32	187	131	150	225	225	169	150	187
90.0	3 35/64	177	124	142	212	212	159	142	177
95.0	3 3/4	168	117	134	201	201	151	134	168
100.0	3 15/16	159	111	127	191	191	143	127	159
110.0	4 11/32	145	101	116	174	174	130	116	145
120.0	4 23/32	133	93	106	159	159	119	106	133
130.0	5 1/8	122	86	98	147	147	110	98	122
140.0	5 1/2	114	80	91	136	136	102	91	114
150.0	5 29/32	106	74	85	127	127	96	85	106



# Drehzahlrichtwerte

## – für Bimetall-Lochsägen HSS / HSSE-Co 8

Material:		Unlegierter Baustahl	Legierter Stahl	Guss-eisen	CuZn-Legierung	Aluminium-Legierung	Thermo-plaste	Duro-plaste	Holz
		bis 700 N/mm <sup>2</sup>	bis 1000 N/mm <sup>2</sup>	über 250 N/mm <sup>2</sup>		bis 11% Si			
Vc = m/min		30	20	10	35	30	20	15	40
Kühlschmierstoff:		Schneidspray	Schneidspray	Druckluft	Druckluft	Schneidspray	Wasser	Druckluft	Druckluft
Ø mm	Ø Zoll	U/min	U/min	U/min	U/min	U/min	U/min	U/min	U/min
14.0	9/16	682	455	227	796	682	455	341	910
16.0	5/8	597	398	199	697	597	398	299	796
17.0	11/16	562	375	187	656	562	375	281	749
19.0	3/4	503	335	168	587	503	335	251	670
21.0	13/16	455	303	152	531	455	303	227	607
22.0	7/8	434	290	145	507	434	290	217	579
24.0	15/16	398	265	133	464	398	265	199	531
25.0	1"	382	255	127	446	382	255	191	510
27.0	1 1/16	354	236	118	413	354	236	177	472
28.0	1 3/32	341	227	114	398	341	227	171	455
29.0	1 1/8	329	220	110	384	329	220	165	439
30.0	1 3/16	318	212	106	372	318	212	159	425
32.0	1 1/4	299	199	100	348	299	199	149	398
33.0	1 5/16	290	193	97	338	290	193	145	386
35.0	1 3/8	273	182	91	318	273	182	136	364
36.0	1 1/4	265	177	88	310	265	177	133	354
37.0	1 7/16	258	172	86	301	258	172	129	344
38.0	1 1/2	251	168	84	293	251	168	126	335
40.0	1 9/16	239	159	80	279	239	159	119	318
41.0	1 5/8	233	155	78	272	233	155	117	311
43.0	1 11/16	222	148	74	259	222	148	111	296
44.0	1 3/4	217	145	72	253	217	145	109	290
46.0	1 13/16	208	138	69	242	208	138	104	277
48.0	1 7/8	199	133	66	232	199	133	100	265
50.0	1 31/32	190	128	64	225	194	129	97	257
51.0	2"	187	125	62	219	187	125	94	250
52.0	2 1/16	184	122	61	214	184	122	92	245
54.0	2 1/8	177	118	59	206	177	118	88	236
57.0	2 1/4	168	112	56	196	168	112	84	223
59.0	2 5/16	162	108	54	189	162	108	81	216
60.0	2 3/8	159	106	53	186	159	106	80	212
63.0	2 15/32	152	101	51	177	152	101	76	202
64.0	2 1/2	149	100	50	174	149	100	75	199
65.0	2 9/16	147	98	49	171	147	98	73	196
67.0	2 5/8	143	95	48	166	143	95	71	190
68.0	2 11/16	141	94	47	164	141	94	70	187
70.0	2 3/4	136	91	45	159	136	91	68	182
73.0	2 7/8	131	87	44	153	131	87	65	175
76.0	3"	126	84	42	147	126	84	63	168
79.0	3 1/8	121	81	40	141	121	81	60	161
83.0	3 1/4	115	77	38	134	115	77	58	153
86.0	3 3/8	111	74	37	130	111	74	56	148
89.0	3 1/2	107	72	36	125	107	72	54	143
92.0	3 5/8	104	69	35	121	104	69	52	138
95.0	3 3/4	101	67	34	117	101	67	50	134
98.0	3 7/8	97	65	32	114	97	65	49	130
102.0	4"	94	62	31	109	94	62	47	125
105.0	4 1/8	91	61	30	106	91	61	45	121
108.0	4 1/4	88	59	29	103	88	59	44	118
111.0	4 3/8	86	57	29	100	86	57	43	115
114.0	4 1/2	84	56	28	98	84	56	42	112
121.0	4 3/4	79	53	26	92	79	53	39	105
127.0	5"	75	50	25	88	75	50	38	100
140.0	5 1/2	68	45	23	80	68	45	34	91
152.0	6"	63	42	21	73	63	42	31	84
160.0	6 5/16	60	40	20	70	60	40	30	80
168.0	6 5/8	57	38	19	66	57	38	28	76
177.0	6 31/32	54	36	18	63	54	36	27	72
210.0	8 1/4	45	30	15	53	45	30	23	61



1



























1



# SÄGEN



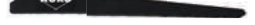























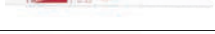

Typen- und Anwendungsübersicht	260 – 263
Stichsägeblätter für Maschinen 8011, 8009, 8010, 8012, 8013, 8017, 8016 HSS	264 – 266
Stichsägeblätter für Maschinen 8028, 8033, 8020, 8019, 8021 HSS-Bimetall	266 – 267
Stichsägeblätter für Maschinen 8005, 8007, 8002, 8006, 8072, 8070, 8001, 8018, 8023, 8024 HCS	268 – 271
Referenztable für RUKO Stichsägeblätter	271
Stichsägeblätter für pneumatische Karosseriesägen 8814, 8824, 8832, 8811, 8812, 8815, 8940 HSS-Bimetall	272 – 274
Säbelsägeblätter für Maschinen 8908, 8906, 8918, 8916, 8913, 8985, 8986, 8989, 8917, 8901, 8943, 8909, 8936, 8945, 8933, 8928, 8937, 8910, 8929 HSS-Bimetall	275 – 281
Säbelsägeblätter für Maschinen 8905, 8903, 8924, 8944, 8923, 8922, 8904 HCS	281 – 283
Handsägeblatt HSS-Co Bihart cobalt	284
Handsägeblatt HSS bi-flexible	284
Sägebogen Kompakt 33	285
Referenztable – für RUKO Säbelsägeblätter	286 – 287

# Typen- und Anwendungsübersicht

	Werkstoff	Oberfläche	Sonstiges	Bezeichnung	Gesamtlänge mm	Sägeblatthöhe mm	Sägeblattstärke mm	Zahnteilung Zähne mm	Zahnteilung Zähne Zoll	Art.-Nr.	Seite
	HSS	Blank		RUKO 8011	77,0	7,5	1,0	2,0	13 Tpi	321 8011 323 8011	264
	HSS	Blank		RUKO 8009	75,0	6,0	1,0	1,2	21 Tpi	321 8009 323 8009	264
	HSS	Blank		RUKO 8010	77,0	7,7	1,0	1,2	21 Tpi	321 8010 323 8010	264
	HSS	Blank		RUKO 8012	77,0	7,6	1,0	0,7	36 Tpi	321 8012 323 8012	265
	HSS	Blank		RUKO 8013	100,0	7,7	1,0	3,0	8 Tpi	321 8013 323 8013	265
	HSS	Blank		RUKO 8017	132,0	7,7	1,25	2,0	13 Tpi	321 8017 323 8017	265
	HSS	Blank		RUKO 8016	130,0	7,9	1,0	1,2	21 Tpi	321 8016 323 8016	266
	HSS	White	Bi Metall	RUKO 8028	77,0	7,7	1,0	2,0	13 Tpi	321 8028 323 8028	266
	HSS	White	Bi Metall	RUKO 8033	77,0	7,5	1,0	1,2	21 Tpi	321 8033 323 8033	266
	HSS	White	Bi Metall	RUKO 8020	132,0	7,7	1,0	1,8	14 Tpi	321 8020 323 8020	267
	HSS	White	Bi Metall	RUKO 8019	132,0	7,7	1,0	1,1	23 Tpi	321 8019 323 8019	267
	HSS	White	Bi Metall	RUKO 8021	100,0	7,5	1,25	4,0	6 Tpi	321 8021 323 8021	267
	HCS	VAP		RUKO 8005	77,0	7,8	1,0	2,0	13 Tpi	321 8005 323 8005	268
	HCS	Blank		RUKO 8007	100,0	7,9	1,3	4,0	6 Tpi	321 8007 323 8007	268
	HCS	Bronze		RUKO 8002	100,0	7,5	1,5	4,0	6 Tpi	321 8002 323 8002	268
	HCS	VAP		RUKO 8006	100,0	7,9	1,3	4,0	6 Tpi	321 8006 323 8006	269
	HCS	Blank		RUKO 8072	100,0	6,2	1,25	4,0	6 Tpi	321 8072 323 8072	269
	HCS	Blank		RUKO 8070	100,0	7,9	1,2	3,0	8 Tpi	321 8070 323 8070	269
	HCS	Blank		RUKO 8001	100,0	7,9	1,3	2,5	10 Tpi	321 8001 323 8001	270
	HCS	Blank		RUKO 8018	100,0	7,3	1,2	2,7	9 Tpi	321 8018 323 8018	270
	HCS	Blank		RUKO 8023	117,0	7,5	1,2	4,0	6 Tpi	321 8023 323 8023	270
	HCS	Blank		RUKO 8024	130,0	7,9	1,3	4,0	6 Tpi	321 8024 323 8024	271
	HSS	VAP	Bi Metall	RUKO 8814	96,0	12,0	0,65	1,8	14 Tpi	321 8814	272
	HSS	VAP	Bi Metall	RUKO 8824	96,0	12,7	0,6	1,0	25 Tpi	321 8824	272
	HSS	VAP	Bi Metall	RUKO 8832	96,0	11,8	0,65	0,8	32 Tpi	321 8832	272
	HSS	VAP	Bi Metall	RUKO 8811	91,5	12,7	0,6	1,0	25 Tpi	321 8811	273
	HSS	VAP	Bi Metall	RUKO 8812	91,5	12,7	0,6	0,8	32 Tpi	321 8812	273

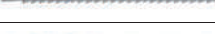
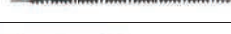
Stahl / Eisen	Aluminium	Buntmetalle	Bleche	Rostfreier Stahl	Beschichtete Platten	Kunststoffe	Profile	Sandwich-Material	Kurvenschnitte	Holz mit Nägeln	Hart- und Weichhölzer	Spanplatten	Tischlerplatten	Sperrholzplatten	Gerader Schnitt	Sauberer Schnitt	Rechtwinklige Schnitte
●	●	●															
●		●	●			●			●								
●	●		●	●					●								
●	●	●	●														
●	●	●				●											
●	●				●		●										
●	●				●		●										
●	●	●		●						●							
●		●	●	●													
●	●						●	●		●							
●	●					●	●			●							
										●	●	●	●				
								●				●	●	●			
								●			●	●	●			●	
								●				●	●		●	●	●
								●				●	●			●	●
								●				●	●			●	●
								●				●	●			●	●
								●				●	●			●	●
	●		●								●						
●		●	●														
●		●	●														
●		●	●														
●		●	●														

# Typen- und Anwendungsübersicht

	Werkstoff	Oberfläche	Sonstiges	Bezeichnung	Gesamtlänge mm	Sägeblatthöhe mm	Sägeblattstärke mm	Zahnteilung Zähne mm	Zahnteilung Zähne Zoll	Art. Nr.	Seite
	HSS	White	Bi Metall	RUKO 8915	152,0	18,0	0,9	2,0	14 Tpi	331 89155	274
	HSS	White	Bi Metall	RUKO 8940	152,0	18,0	0,9	1,45-3,4	8-18 Tpi	331 89405	274
	HSS	White	Bi Metall	RUKO 8908	150,0	18,0	0,9	1,4	18 Tpi	331 89085	275
	HSS	White	Bi Metall	RUKO 8906	152,0	18,4	0,9	1,0	24 Tpi	331 89065	275
	HSS	White	Bi Metall	RUKO 8918	203,0	17,8	1,25	1,8-2,6	10-14 Tpi	331 89185	275
	HSS	White	Bi Metall	RUKO 8916	228,0	18,4	0,9	2,0	14 Tpi	331 89165	276
	HSS	White	Bi Metall	RUKO 8913	228,0	18,4	0,9	1,4	18 Tpi	331 89135	276
	HSS	White	Bi Metall	RUKO 8985	152,0	21,0	1,6	4,2	6 Tpi	331 89855	276
	HSS	White	Bi Metall	RUKO 8986	152,0	21,0	1,6	2,54-3,18	8-10 Tpi	331 89865	277
	HSS	White	Bi Metall	RUKO 8989	228,0	21,0	1,6	2,54-3,18	8-10 Tpi	331 89895	277
	HSS	White	Bi Metall	RUKO 8917	152,0	18,0	1,25	4,2	6 Tpi	331 89175	278
	HSS	White	Bi Metall	RUKO 8901	152,0	18,0	0,9	2,5	10 Tpi	331 89015	278
	HSS	White	Bi Metall	RUKO 8943	203,0	18,0	1,25	2,1-4,3	6-12 Tpi	331 89435	278
	HSS	White	Bi Metall	RUKO 8909	203,0	18,0	0,9	2,5	10 Tpi	331 89095	279
	HSS	White	Bi Metall	RUKO 8936	228,0	18,0	1,25	4,25	6 Tpi	331 89365	279
	HSS	White	Bi Metall	RUKO 8945	228,0	18,0	0,9	2,54	10 Tpi	331 89455	279
	HSS	White	Bi Metall	RUKO 8933	228,0	18,0	1,25	1,8-2,6	10-14 Tpi	331 89335	280
	HSS	White	Bi Metall	RUKO 8928	228,0	18,0	0,9	1,8-2,6	10-14 Tpi	33189285	280
	HSS	White	Bi Metall	RUKO 8937	305,0	18,0	1,25	4,2	6 Tpi	33189375	280
	HSS	White	Bi Metall	RUKO 8910	305,0	18,0	0,9	1,8-2,4	10-14 Tpi	331 89105	281
	HSS	White	Bi Metall	RUKO 8929	305,0	18,0	1,25	1,8-2,4	10-14 Tpi	331 89295	281
	HCS	Blank		RUKO 8905	152,0	18,35	1,25	1,8-2,4	10-14 Tpi	331 89055	281
	HCS	Blank		RUKO 8903	152,0	18,35	1,0	4,2	6 Tpi	331 89035	282
	HCS	Blank		RUKO 8924	152,0	18,1	1,25	4,0	6 Tpi	331 89245	282
	HCS	Blank		RUKO 8944	203,0	18,1	1,25	2,4-4,0	6-10 Tpi	331 89445	282
	HCS	Blank		RUKO 8923	225,0	18,0	1,25	8,5	3 Tpi	331 89235	283
	HCS	Blank		RUKO 8922	240,0	18,0	1,6	4,0-6,5	5 Tpi	331 89225	283
	HCS	Blank		RUKO 8904	300,0	18,0	1,25	4,2	6 Tpi	331 89045	283
		Blank	Bi Metall		300,0	13,0	0,65	80-120	18-32 Tpi	3121 300 xx R	284
		Bronze	Bi Metall		300,0	13,0	0,65	80-120	8-12 Tpi	3181 300 xx R	284



Stahl / Eisen	Aluminium	Buntmetalle	Bleche	Rostfreier Stahl	Beschichtete Platten	Kunststoffe	Profile	Sandwich-Material	Kurvenschnitte	Holz mit Nägeln	Hart- und Weichhölzer	Spanplatten	Tischlerplatten	Sperrholzplatten	Gerader Schnitt	Sauberer Schnitt	Rechtwinklige Schnitte
●		●	●	●	●		●										
			●				●										
			●		●		●										
			●		●		●										
			●		●		●										
●		●	●		●		●										
●			●		●		●										
						●				●		●					●
			●		●		●					●					●
			●		●		●					●					●
						●				●		●					●
●	●		●		●					●	●						
	●		●		●		●			●							
●	●		●		●					●	●						
●						●				●		●					
●	●		●		●					●	●						
●	●		●		●					●							
●						●	●	●		●		●					
●	●		●		●					●							
●	●		●		●					●							
									●		●	●	●	●	●		
						●					●						
						●	●	●			●	●		●			
						●	●		●		●	●	●	●			
									●		●	●	●	●			
●		●		●			●				●	●	●	●	●		
●		●					●										

# Stichsägeblätter für Maschinen von Bosch®, Metabo®, MP.S®, Wilpu®, Atlas Copco® / AEG® u. a.



Stichsägeblätter anderer Hersteller \*  
Bosch® T 118 B | Metabo® 23 638  
MPS® 3113 | Wilpu® MG 12 | AEG® 254-064

## RUKO 8011 HSS

Standardsägeblatt, gewellt.

Verwendung für:

St 37 bis 4,0 mm, nichtrostender Stahl, Buntmetalle und Alu von 3,0 - 10,0 mm, mit RUKO-Schneidspray kühlen.  
Harte Kunststoffe und Plexiglas 3,0 - 8,0 mm, Pertinax und Resitex mit Wasser kühlen. Asbestzement 2,0 - 4,0 mm, Eternit bis 10,0 mm, mit Wasser kühlen.



mm	mm	mm	Zahnteilung Zähne mm	Zahnteilung Zähne Zoll				
77,0	7,5	1,0	2,0	13 Tpi	321 8011	5	323 8011	20



Stichsägeblätter anderer Hersteller \*  
Bosch® T 218 A | Metabo® 23 647  
MPS® 3112 | Wilpu® MG 21 | AEG® 254-063

## RUKO 8009 HSS

Standardsägeblatt, gewellt. Schmales Blatt, für Kurvenschnitte geeignet.

Verwendung für:

St 37, rostfreie Stahlbleche bis 2,0 mm, Buntmetalle zum Kurvenschneiden geeignet.  
Für glasfaserverstärkte Kunststoffe bis 4,0 mm geeignet, Plexiglas bis 8,0 mm mit Wasser kühlen.  
Pressstoff, Hartgewebe und Isolationsmaterial bis 8,0 mm Materialstärke mit Wasser kühlen.



mm	mm	mm	Zahnteilung Zähne mm	Zahnteilung Zähne Zoll				
75,0	6,0	1,0	1,2	21 Tpi	321 8009	5	323 8009	20

11

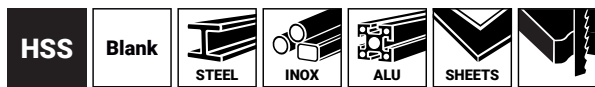

Stichsägeblätter anderer Hersteller \*  
Bosch® T 118 A | Metabo® 23 637  
MPS® 3111 | Wilpu® MG 11 | AEG® 254-063

## RUKO 8010 HSS

Standardsägeblatt, gewellt. Schmales Blatt, für Kurvenschnitte geeignet.

Verwendung für:

St 37, Buntmetalle und Aluminium bis 4,0 mm, rostfreies Stahlblech bis 2,0 mm mit RUKO-Schneidspray kühlen.  
Hartholz und Weichholz bis 8,0 mm. Für glasfaserverstärkte Kunststoffe bis 2,0 mm geeignet, Acrylglas mit Wasser kühlen. Pressstoff, Hartgewebe und Plexiglas mit Wasser kühlen, Isolationsmaterial bis 8,0 mm Materialstärke.



mm	mm	mm	Zahnteilung Zähne mm	Zahnteilung Zähne Zoll				
77,0	7,7	1,0	1,2	21 Tpi	321 8010	5	323 8010	20

# Stichsägeblätter für Maschinen von Bosch®, Metabo®, MP.S®, Wilpu®, Atlas Copco® / AEG® u. a.



Stichsägeblätter anderer Hersteller \*  
Bosch® T 118 G | Metabo® 23 636  
MPS® 3110 | Wilpu® MG 107 | AEG® 274-652







## RUKO 8012 HSS

Standardsägeblatt, gewellt. Für dünne Bleche.

Verwendung für:

Dünnwandige Bleche und Profile unter 1,0 mm. St 37, Buntmetalle und Aluminium bis 2,0 mm mit RUKO-Schneid-spray kühlen. Armierte Kunststoffe und Plexiglas mit Wasser kühlen. Dünnwandige Hartgewebe, Pressstoffe und Isolationsmaterial mit Wasser kühlen.

			Zahnteilung Zähne mm	Zahnteilung Zähne Zoll		
77,0	7,6	1,0	0,7	36 Tpi	321 8012	5

323 8012	20
----------	----



Stichsägeblätter anderer Hersteller \*  
Bosch® T 127 D | Metabo® 23 639  
MPS® 3118 | Wilpu® K 14 | AEG® 274-315







## RUKO 8013 HSS

Standardsägeblatt geschränkt.

Verwendung für:

Weichstahl von 3,0 - 6,0 mm, Buntmetalle, Aluminium und Aluminiumlegierungen von 3,0 - 15,0 mm mit RUKO-Schneidspray kühlen. Kunststoffe und armierte Kunststoffe. Asbestzement, Eternit und Hartstoffe.

			Zahnteilung Zähne mm	Zahnteilung Zähne Zoll		
100,0	7,7	1,0	3,0	8 Tpi	321 8013	5

323 8013	20
----------	----



Stichsägeblätter anderer Hersteller \*  
Bosch® T 318 B | Metabo® 23 697  
MPS® 3115 | Wilpu® MG 32 bi | AEG® 274-653







## RUKO 8017 HSS

Standardsägeblatt extra lang und gewellt.

Verwendung für:

Profile, Weichstahl und Aluminium von 2,0 - 10,0 mm, Verbundwerkstoffe und Sandwichmaterial bis 70,0 mm. Isolationsmaterial.

			Zahnteilung Zähne mm	Zahnteilung Zähne Zoll		
132,0	7,7	1,25	2,0	13 Tpi	321 8017	5

323 8017	20
----------	----

# Stichsägeblätter für Maschinen von Bosch®, Metabo®, MP.S®, Wilpu®, Atlas Copco® / AEG® u. a.

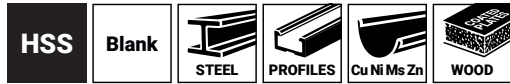

Stichsägeblätter anderer Hersteller \*  
Bosch® T 318 A | Metabo® 23 629  
MPS® 3114 | Wilpu® MG 31 bi | AEG® 274-654



## RUKO 8016 HSS

Standardsägeblatt extra lang und gewellt.

Verwendung für:  
Profile, Weichstahl und Aluminium von 1,5 - 4,0 mm, Verbundwerkstoffe und Sandwichmaterial bis 70,0 mm.  
Isolationsmaterial.

mm	mm	mm	Zahnteilung Zähne mm	Zahnteilung Zähne Zoll				
130,0	7,9	1,0	1,2	21Tpi	321 8016	5	323 8016	20

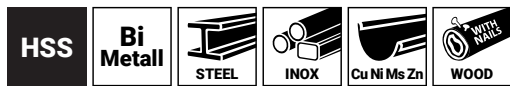

Stichsägeblätter anderer Hersteller \*  
Bosch® T 118 BF | Metabo® 23 973  
MPS® 3113 F | Wilpu® MG 12 bi | AEG® 340-012



## RUKO 8028 HSS-Bimetal

Sägeblatt gewellt.

Verwendung für:  
Weichstahl und Buntmetalle von 3,0 - 10,0 mm Materialstärke, sowie rostfreie Stahlbleche.  
Holz mit Nägeln. Plexiglas.

mm	mm	mm	Zahnteilung Zähne mm	Zahnteilung Zähne Zoll				
77,0	7,7	1,0	2,0	13 Tpi	321 8028	5	323 8028	20

11

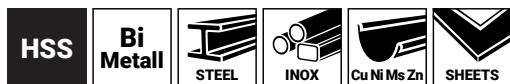

Stichsägeblätter anderer Hersteller \*  
Bosch® T 118 AF | Metabo® 23 971  
MPS® 3111 F | Wilpu® MG 11 bi | AEG® 340-011



## RUKO 8033 HSS-Bimetal

Sägeblatt gewellt.

Verwendung für:  
Weichstahl, Buntmetalle, Aluminium und Aluminiumlegierungen von 1,5 - 4,0 mm, rostfreies Stahlblech, V2A.

mm	mm	mm	Zahnteilung Zähne mm	Zahnteilung Zähne Zoll				
77,0	7,5	1,0	1,2	21 Tpi	321 8033	5	323 8033	20

# Stichsägeblätter für Maschinen von Bosch®, Metabo®, MP.S®, Wilpu®, Atlas Copco® / AEG® u. a.



Stichsägeblätter anderer Hersteller \*  
Bosch® T 318 BF | Metabo® 23 979  
MP.S® 3115 F | Wilpu® MG 32 bi | AEG® 274-653

## RUKO 8020 HSS-Bimetall

Sägeblatt geschränkt.

Verwendung für:

Profile und Rohre bis Ø 60,0 mm bei 3,0 - 10,0 mm Wandstärke, Buntmetalle und V2A-Stähle.  
Holz mit Nägeln. Plexiglas und armierte Kunststoffe.



mm	mm	mm	Zahnteilung Zähne mm	Zahnteilung Zähne Zoll				
132,0	7,7	1,0	1,8	14 Tpi	321 8020	5	323 8020	20



Stichsägeblätter anderer Hersteller \*  
Bosch® T 318 AF | Metabo® 23 978  
MP.S® 3114 F | Wilpu® MG 31 bi | AEG® 274-654

## RUKO 8019 HSS-Bimetall

Sägeblatt gewellt.

Verwendung für:

Profile und Rohre bis Ø 65,0 mm bei 1,4 - 4,0 mm Wandstärke, V2A-Stähle.



mm	mm	mm	Zahnteilung Zähne mm	Zahnteilung Zähne Zoll				
132,0	7,7	1,0	1,1	23 Tpi	321 8019	5	323 8019	20



Stichsägeblätter anderer Hersteller \*  
Bosch® T 144 DF | Metabo® 23 978  
MP.S® 3104 F | Wilpu® HGS 14 bi | AEG® 373 391

## RUKO 8021 HSS-Bimetall

Sägeblatt geschärft und geschränkt.

Verwendung für:

Hartholz und Weichholz bis 50,0 mm, rauher Schnitt, große Schnittleistung, für Holz mit Nägeln geeignet.



mm	mm	mm	Zahnteilung Zähne mm	Zahnteilung Zähne Zoll				
100,0	7,5	1,25	4,0	6 Tpi	321 8021	5	323 8021	20

# Stichsägeblätter für Maschinen von Bosch®, Metabo®, MP.S®, Wilpu®, Atlas Copco® / AEG® u. a.

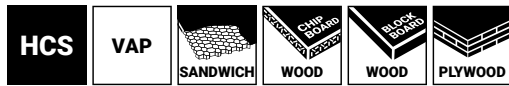

Stichsägeblätter anderer Hersteller \*  
Bosch® T 119 B | Metabo® 23 631  
MP.S® 3108 | Wilpu® HW 12 | AEG® 274-353

## RUKO 8005 HCS

Standardsägeblatt, gewellt.

Verwendung für:  
Sperrholz- und Holzfaserplatten bis 30,0 mm Materialstärke. Isolierstoffe und Plexiglas bis 6,0 mm mit Wasser kühlen. Pressstoff und Hartgewebe bis 4,0 mm Materialstärke, Karton und Linoleum bis 6,0 mm Materialstärke, mit Wasser kühlen.



mm	mm	mm	Zahnteilung Zähne mm	Zahnteilung Zähne Zoll		
77,0	7,8	1,0	2,0	13 Tpi	321 8005	5

323 8005	20
----------	----



Stichsägeblätter anderer Hersteller \*  
Bosch® T 101 D | Metabo® 23 635  
MP.S® 3105 | Wilpu® HGS 24 | AEG® 274-351

## RUKO 8007 HCS

Schmales Sägeblatt für Kurvenschnitte geeignet.  
Schneller und rauher Schnitt. Blatt konisch, Zahnung geschliffen.

Verwendung für:  
Hartholz, Weichholz, Sperrholz und Holzfaserplatten bis 50,0 mm, sauberer Schnitt, geeignet zum Einstechen.  
Verschiedene weiche Kunststoffe bis 30,0 mm, sauberer Schnitt.



mm	mm	mm	Zahnteilung Zähne mm	Zahnteilung Zähne Zoll		
100,0	7,9	1,3	4,0	6 Tpi	321 8007	5

323 8007	20
----------	----

11



Stichsägeblätter anderer Hersteller \*  
Bosch® T 101 DP | Metabo® 23 971  
MP.S® 3111 F | Wilpu® MG 11 bi | AEG® 340-011

## RUKO 8002 HCS

Sauberer und schneller Schnitt. Blatt konisch, Zahnung geschliffen.

Verwendung für:  
Hartholz, Weichholz, Sperrholz- und Holzfaserplatten bis 60,0 mm, parallele Schnitte, sauberer Schnitt.  
Verschiedene weiche Kunststoffe bis 25,0 mm, sauberer Schnitt.



mm	mm	mm	Zahnteilung Zähne mm	Zahnteilung Zähne Zoll		
100,0	7,5	1,5	4,0	6 Tpi	321 8002	5

323 8002	20
----------	----

# Stichsägeblätter für Maschinen von Bosch®, Metabo®, MP.S®, Wilpu®, Atlas Copco® / AEG® u. a.

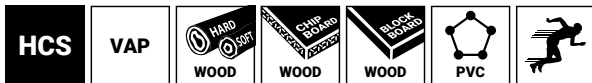

Stichsägeblätter anderer Hersteller \*  
Bosch® T 144 D | Metabo® 23 633  
MP.S® 3104 | Wilpuv HGS 14 | AEG® 213-116

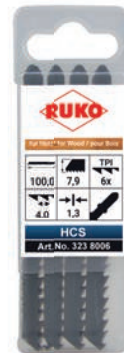

## RUKO 8006 HCS

Sägeblatt geschränkt und geschärft. Schneller und rauher Schnitt.

Verwendung für:

Hartholz und Weichholz bis 50,0 mm, schneller und rauher Schnitt. Polystyrol, Polyamid und weiche Kunststoffe bis 50,0 mm, Plexiglas bis 30,0 mm, mit Wasser kühlen. Hartgewebe, Isolationsmaterial und Karton.

mm	mm	mm	Zahnteilung Zähne mm	Zahnteilung Zähne Zoll				
100,0	7,9	1,3	4,0	6 Tpi	321 8006	5	323 8006	20



Stichsägeblätter anderer Hersteller \*  
Bosch® T 244 D | Metabo® 23 649  
MP.Sv 3105 | Wilpu® HGS 24 | AEG® 346-078



## RUKO 8072 HCS

Schmales Sägeblatt für Kurvenschnitte geeignet.  
Schneller und rauher Schnitt. Blatt konisch, Zahnung geschliffen.

Verwendung für:

Hartholz und Weichholz bis 50,0 mm, rauher Schnitt, besonders geeignet zum Kurvenschneiden.  
Polystyrol, Polyamid und weiche Kunststoffe bis 50,0 mm.

mm	mm	mm	Zahnteilung Zähne mm	Zahnteilung Zähne Zoll				
100,0	6,2	1,25	4,0	6 Tpi	321 8072	5	323 8072	20



Stichsägeblätter anderer Hersteller \*  
Bosch® T 111 C | Metabov 23 632  
MP.S® - | Wilpu® HG 13 | AEG® 254-071



## RUKO 8070 HCS

Sauberer und schneller Schnitt. Blatt konisch, Zahnung geschliffen.

Verwendung für:

Hartholz und Weichholz bis 50,0 mm, rauher Schnitt, große Schnittleistung.  
Polystyrol, Polyamid und weiche Kunststoffe bis 30,0 mm.

mm	mm	mm	Zahnteilung Zähne mm	Zahnteilung Zähne Zoll				
100,0	7,9	1,2	3,0	8 Tpi	321 8070	5	323 8070	20

# Stichsägeblätter für Maschinen von Bosch®, Metabo®, MP.S®, Wilpu®, Atlas Copco® / AEG® u. a.

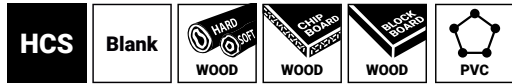

Stichsägeblätter anderer Hersteller \*  
Bosch® T 101 B | Metabo® 23 634  
MP.S® 3101 | Wilpu® HC 12 | AEG® 254-061

## RUKO 8001 HCS

Sauberer und schneller Schnitt. Blatt konisch, Zahnung geschliffen.

Verwendung für:  
Hartholz, Weichholz, Sperrholz und Holzfaserplatten bis 50,0 mm Materialstärke, zum Einstechen geeignet.  
Verschiedene weiche Kunststoffe bis 20,0 mm.



mm	mm	mm	Zahnteilung Zähne mm	Zahnteilung Zähne Zoll				
100,0	7,9	1,3	2,5	10 Tpi	321 8001	5	323 8001	20



Stichsägeblätter anderer Hersteller \*  
Bosch® T 101 BR | Metabo® 23 650  
MP.S® 3102 | Wilpu® HC 12 R | AEG® 346-079

## RUKO 8018 HCS

Sauberer Schnitt. Blatt konisch, Zahnung geschliffen. Umgekehrte Schneidrichtung.

Verwendung für:  
Hartholz, Weichholz, Sperrholz und Holzfaserplatten bis 60,0 mm, Resopalplatten und beschichtete Platten.  
Weiche Kunststoffe.



mm	mm	mm	Zahnteilung Zähne mm	Zahnteilung Zähne Zoll				
100,0	7,3	1,2	2,7	9 Tpi	321 8018	5	323 8018	20

11



Stichsägeblätter anderer Hersteller \*  
Bosch® T 301 D | Metabo® 23 654  
MP.S® 3101 L

## RUKO 8023 HCS

Blatt konisch, Zahnung geschliffen.

Verwendung für:  
Hartholz, Weichholz, Sperrholz und Holzfaserplatten bis 70,0 mm, sauberer Schnitt, geeignet zum Einstechen.  
Verschiedene weiche Kunststoffe bis 40,0 mm, sauberer Schnitt.



mm	mm	mm	Zahnteilung Zähne mm	Zahnteilung Zähne Zoll				
117,0	7,5	1,2	4,0	6 Tpi	321 8023	5	323 8023	20



# Stichsägeblätter für Maschinen von Bosch®, Metabo®, MP.S®, Wilpu®, Atlas Copco® / AEG® u. a.



Stichsägeblätter anderer Hersteller \*  
Bosch® T 301 DL | MP.S® 3104 L  
Wilpu® HGS 34

## RUKO 8024 HCS

Sehr sauberer und schneller Schnitt. Blatt konisch, Zahnung geschliffen.

Verwendung für:

Hartholz, Weichholz, Sperrholz- und Holzfaserplatten bis 70,0 mm, sauberer und schneller Schnitt, geeignet zum Einstechen. Verschiedene weiche Kunststoffe bis 40,0 mm, sauberer Schnitt.



			Zahnteilung Zähne mm	Zahnteilung Zähne Zoll			
130,0	7,9	1,3	4,0	6 Tpi	321 8024	5	
						323 8024	20

## Referenztablelle für RUKO Stichsägeblätter

Die technischen Daten der Sägeblätter anderer Hersteller können von unseren abweichen.

	Bosch®	D+N®	Gematic®	Hawera®	Lenox®	Metabo®	MP.S®	Wilpu®	Atlas Copco® AEG®	Holz-Her®	Festo®
321 8001	T 101 B	3 22 25	10 2255	240 515	F 450 S	23 634	3101	HC 12	254-061	Ho 75 F	S 75/2,5
321 8002	T 101 DP	3 29 40	10 2258	240 516	F 456 S	23 655	3103	HC 14 D	274-351	—	S 75/4
321 8005	T 119 B	3 20 20	10 2249	144 212	F 410 S	23 631	3108	HW 12	274-353	SP 50 G	—
321 8006	T 144 D	3 23 40	10 2270	240 520	F 406 S	23 633	3104	HGS 14	213-116	HW 75 G	S75/4
321 8007	T 101 D	3 22 40	—	240 521	F 416 SC	23 635	3105	HGS 24	274-351	HO 75 G	—
321 8009	T 218 A	3 13 12	10 2104	240 523	F 324 S	23 647	3112	MG 21	254-063	ME 50 M	—
321 8010	T 118 A	3 10 12	—	—	F 318 SC	23 637	3111	MG 11	254-063	AK 50 M	HS 50/1.2
321 8011	T 118 B	3 10 20	10 2107	240 525	F 340 SV	23 638	3113	MG 12	254-064	ME 50 G	HS 50/2
321 8012	T 118 G	3 10 07	10 2101	240 526	—	23 636	3110	MG 107	274-652	ME 50 F	—
321 8013	T 127 D	3 10 30	10 2110	240 528	F 410 S	23 639	3118	K 14	274-315	AL 75 G	HS 75/3
321 8016	T 318 A	3 11 12	10 2113	240 527	F 518 S	23 629	3114	MG 31 bi	274-654	AK 100 M	—
321 8017	T 318 B	3 11 20	10 2116	240 534	F 410 S	23 697	3115	MG 32 bi	274-653	ME 100 G	—
321 8018	T 101 BR	3 26 25	10 2264	240 545	F 450 SR	23 650	3102	HC 12 R	346-079	—	—
321 8019	T 318 AF	3 15 12	—	144 223	F 324 S	23 978	—	MG 31 bi	274-654	HS 105 / 1,2 bi	—
321 8020	T 318 BF	3 15 20	—	144 227	—	23 979	3115 F	MG 32 bi	274-653	HS 105 / 2,0 bi	—
321 8021	T 144 DF	3 33 40	—	144 220	F 456 S	23 976 23 933	3104 F	HGS 14 bi	373-391	—	HS 75/4 bi
321 8023	T 301 D	3 27 40	—	—	F 410 S	23 654	3101 L	—	—	HO 90 G	—
321 8024	T 301 DL	3 40 40	10 2253	144 213	F 686 S	—	3104 L	HGS 34	—	—	—
321 8028	T 118 BF	3 14 20	10 2322	144 225	F 314 S	23 973	3113 F	MG 12 bi	340-012	—	—
321 8033	T 118 AF	3 14 12	10 2319	240 503	F 324 S	23 971	3111 F	MG 11 bi	340-011	—	—
321 8070	T 111 C	3 20 30	—	—	—	23 632	—	HG 13	254-071	HO 75 R	S 75/3
321 8072	T 244 D	3 24 40	—	—	—	23 649	3105	HGS 24	346-078	HW 75 K	S 75/4 K



# Stichsägeblätter für pneumatische Karoseriesägen von SIG®, FLEX® und Wieländer + Schill®



Stichsägeblätter anderer Hersteller \*  
CS 118 BF

## RUKO 8814 HSS-Bimetall

Für dünne Bleche z. B. Karosseriebleche.

Verwendung für:  
St 37 und Buntmetalle bis 2,5 mm. Holz, Kunststoffe, Hartgewebe.

mm	mm	mm	Zahnteilung Zähne mm	Zahnteilung Zähne Zoll		
96,0	12	0,65	1,8	14 Tpi	321 8814	5



Stichsägeblätter anderer Hersteller \*  
CS 118 AF

## RUKO 8824 HSS-Bimetall

Für dünne Bleche z. B. Karosseriebleche.

Verwendung für:  
St 37, V2A und Buntmetalle bis 2,0 mm. Für Kurvenschnitte geeignet.

mm	mm	mm	Zahnteilung Zähne mm	Zahnteilung Zähne Zoll		
96,0	12,7	0,6	1,0	25 Tpi	321 8824	5



Stichsägeblätter anderer Hersteller \*  
CS 118 6F

## RUKO 8832 HSS-Bimetall

Für dünne Bleche z. B. Karosseriebleche.

Verwendung für:  
St 37, V2A und Buntmetalle bis 1,0 mm. Für Kurvenschnitte geeignet.

mm	mm	mm	Zahnteilung Zähne mm	Zahnteilung Zähne Zoll		
96,0	11,8	0,65	0,8	32 Tpi	321 8832	5



# Stichsägeblätter für pneumatische Karosseriesägen von Ober®, Chicago Pneumatic®, Shinano®, Facom® und Pneutec®



Stichsägeblätter anderer Hersteller \*  
CC 118 AF

## RUKO 8811 HSS-Bimetall

Für dünne Bleche z. B. Karosseriebleche.

Verwendung für:  
St 37, V2A und Buntmetalle bis 2,0 mm. Für Kurvenschnitte geeignet.

mm	mm	mm	Zahnteilung Zähne mm	Zahnteilung Zähne Zoll		
91,5	12,7	0,6	1,0	25 Tpi	321 8811	5

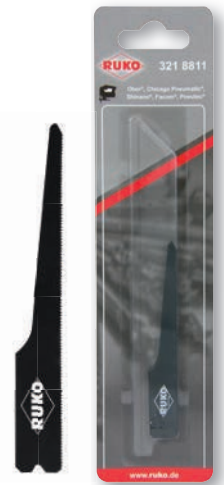

Stichsägeblätter anderer Hersteller \*  
CC 118 GF

## RUKO 8812 HSS-Bimetall

Für dünne Bleche z. B. Karosseriebleche.

Verwendung für:  
St 37, V2A und Buntmetalle bis 1,0 mm. Für Kurvenschnitte geeignet.

mm	mm	mm	Zahnteilung Zähne mm	Zahnteilung Zähne Zoll		
91,5	12,7	0,6	0,8	32 Tpi	321 8812	5





Säbelsägeblätter anderer Hersteller \*  
 Bosch® S 922 | Metabo® 31130  
 MPS® 4411 | Wilpu® 3013-150 | AEG® 354-789

## RUKO 8915 HSS-Bimetall

Zahnung geschränkt und gefräst.

Verwendung für:

Starke Bleche von 3,0 - 8,0 mm Materialstärke, massive Rohre und Profile von Ø 10,0 - 100,0 mm, schneller Schnitt.

mm	mm	mm	Zahnteilung Zähne mm	Zahnteilung Zähne Zoll		
152,0	18,0	0,9	2,0	14 Tpi	331 89155	5



Säbelsägeblätter anderer Hersteller \*  
 Bosch® S 123 XF | MPS® 4446

## RUKO 8940 HSS-Bimetall

Zahnung geschränkt und gefräst.

Verwendung für:

Dünne bis starke Bleche von 1,0 - 8,0 mm Materialstärke, dünne bis kräftige Profile von Ø 5,0 - 100,0 mm.

mm	mm	mm	Zahnteilung Zähne mm	Zahnteilung Zähne Zoll		
152,0	18,0	0,9	1,45 - 3,4	8 - 18 Tpi	331 89405	5



# Säbelsägeblätter für Maschinen

von Bosch®, Metabo®, MP.S®, Wilpu®, Atlas Copco® / AEG® u. a.



Säbelsägeblätter anderer Hersteller \*  
 Bosch® S 922 EF | Metabo® 31132  
 MP.S® 4401 | Wilpu® 3014-150 | AEG® 354-792

## RUKO 8908 HSS-Bimetall

Zahnung geschränkt und gefräst.

Verwendung für:

Dünne Bleche von 1,5 - 4,0 mm Materialstärke, Rohre und Profile von Ø 5,0 - 100,0 mm.

mm	mm	mm	Zahnteilung Zähne mm	Zahnteilung Zähne Zoll		
150,0	18,0	0,9	1,4	18 Tpi	331 89085	5



Säbelsägeblätter anderer Hersteller \*  
 Bosch® S 922 AF | Metabo® 31129  
 MP.S® 4405 | Wilpu® 3015-150 | AEG® 354-796

## RUKO 8906 HSS-Bimetall

Zahnung geschränkt und gefräst.

Verwendung für:

Dünne Bleche von 0,7 - 3,0 mm Materialstärke, feine Rohre und Profile von Ø 5,0 - 100,0 mm.

Müheloser, feiner Schnitt.

mm	mm	mm	Zahnteilung Zähne mm	Zahnteilung Zähne Zoll		
152,0	18,4	0,9	1,0	24 Tpi	331 89065	5



Säbelsägeblätter anderer Hersteller \*  
 Bosch® S 1025 VF

## RUKO 8918 HSS-Bimetall

Zahnung geschränkt und gefräst.

Verwendung für:

Mittelstarke bis starke Bleche von 2,0 - 10,0 mm Materialstärke, massive Rohre und Profile von Ø 10,0 - 150,0 mm.

Müheloser, feiner Schnitt.

mm	mm	mm	Zahnteilung Zähne mm	Zahnteilung Zähne Zoll		
203,0	17,8	1,25	1,8 - 2,6	10 - 14 Tpi	331 89185	5



# Säbelsägeblätter für Maschinen von Bosch®, Metabo®, MP.S®, Wilpu®, Atlas Copco® / AEG® u. a.



Säbelsägeblätter anderer Hersteller \*  
Bosch® S 1122 BF | Metabo® 31135 / 31485  
MP.S® 4415 | AEG® 354-790 | Wilpu® 3013-250

## RUKO 8916 HSS-Bimetall

Zahnung geschränkt und gefräst.

Verwendung für:  
Starke Bleche von 3,0 - 8,0 mm Materialstärke, massive Rohre und Profile von Ø 10,0 - 175,0 mm.  
Flexibler, bündiger und schneller Schnitt.

mm	mm	mm	Zahnteilung Zähne mm	Zahnteilung Zähne Zoll		
228,0	18,4	0,9	2,0	14 Tpi	331 89165	5



Säbelsägeblätter anderer Hersteller \*  
Bosch® S 1122 EF | Metabo® 31133 / 31483  
MP.S® 4402 | AEG® 354-793 | Wilpu® 3014-200

## RUKO 8913 HSS-Bimetall

Zahnung geschränkt und gefräst.

Verwendung für:  
Dünne Bleche von 1,5 - 4,0 mm Materialstärke, Rohre und Profile von Ø 5,0 - 175,0 mm.  
Flexibler, bündiger Schnitt.

mm	mm	mm	Zahnteilung Zähne mm	Zahnteilung Zähne Zoll		
228,0	18,4	0,9	1,4	18 Tpi	331 89135	5



11



Säbelsägeblätter anderer Hersteller \*  
Bosch® S 610 DF | Metabo® 31925  
AEG® 373-243 | Wilpu® 3055-150

## RUKO 8985 HSS-Bimetall

Zahnung geschränkt und gefräst.

Verwendung für:  
Holz mit Nägeln, Metall, Spanplatten von 10,0 - 100,0 mm Materialstärke, Kunststoffprofile von Ø 5,0 - 100,0 mm,  
massive Kunststoffe / GFK von 8,0 - 50,0 mm, Fensterrahmen aus Holz und Metall.  
Speziell für Tauchschnitte geeignet.

mm	mm	mm	Zahnteilung Zähne mm	Zahnteilung Zähne Zoll		
152,0	21,0	1,6	4,2	6 Tpi	331 89855	5



# Säbelsägeblätter für Maschinen von Bosch®, Metabo®, MP.S®, Wilpu®, Atlas Copco® / AEG® u. a.



Säbelsägeblätter anderer Hersteller \*  
Bosch® S 920 CF | AEG® 373-247

## RUKO 8986 HSS-Bimetall

Zahnung geschränkt und gefräst.

Verwendung für:

Platten von 4,0 - 10,0 mm, massive Rohre und Profile von Ø 20,0 - 100,0 mm.

Ideal für Rohrschneidevorrichtung und Rettungs-/ Abbrucharbeiten. Kraftvoller und grober Schnitt.

mm	mm	mm	Zahnteilung Zähne mm	Zahnteilung Zähne Zoll		
152,0	21,0	1,6	2,54 - 3,18	8 - 10 Tpi	331 89865	5



Säbelsägeblätter anderer Hersteller \*  
Bosch® S 1120 CF | Metabo® 31993  
Wilpu® 3055-225 | AEG® 373-244

## RUKO 8989 HSS-Bimetall

Zahnung geschränkt und gefräst.

Verwendung für:

Platten von 4,0 - 12,0 mm, massive Rohre und Profile von Ø 20,0 - 175,0 mm.

Ideal für Rohrschneidevorrichtung und Rettungs-/ Abbrucharbeiten. Kraftvoller und grober Schnitt.

mm	mm	mm	Zahnteilung Zähne mm	Zahnteilung Zähne Zoll		
228,0	21,0	1,6	2,54 - 3,18	8 - 10 Tpi	331 89895	5



# Säbelsägeblätter für Maschinen von Bosch®, Metabo®, MP.S®, Wilpu®, Atlas Copco® / AEG® u. a.



Säbelsägeblätter anderer Hersteller \*  
Bosch® S 611 DF | Metabo® 31985  
MP.S® 4016 | AEG® 354-775 | Wilpu® 3021/150bi

## RUKO 8917 HSS-Bimetall

Zahnung geschränkt und gefräst.

Verwendung für:

Holz mit Nägeln, Metall, Spanplatten von 10,0 - 100,0 mm Materialstärke, Kunststoffprofile von Ø 5,0 - 100,0 mm, massive Kunststoffe / GFK von 8,0 - 50,0 mm, Fensterrahmen aus Holz und Metall. Speziell für Tauchschnitte geeignet.

mm	mm	mm	Zahnteilung Zähne mm	Zahnteilung Zähne Zoll		
152,0	18,0	1,25	4,2	6 Tpi	331 89175	5



Säbelsägeblätter anderer Hersteller \*  
Bosch® S 922 HF | Metabo® 31131  
MP.S® 4430 | AEG® 318-127 | Wilpu® 3018/150

## RUKO 8901 HSS-Bimetall

Zahnung geschränkt und gefräst.

Verwendung für:

Holz mit Nägeln und Metall von 5,0 - 100,0 mm Materialstärke, Metallbleche, Rohre, Aluprofile von 3,0 - 12,0 mm und Paletten.

mm	mm	mm	Zahnteilung Zähne mm	Zahnteilung Zähne Zoll		
152,0	18,0	0,9	2,5	10 Tpi	331 89015	5



11



Säbelsägeblätter anderer Hersteller \*  
Bosch® S 3456 XF | Metabo® 31915  
MP.S® 4447

## RUKO 8943 HSS-Bimetall

Zahnung geschränkt und gefräst.

Verwendung für:

Holz mit Nägeln und Metall, Spanplatten von 5,0 - 150,0 mm Materialstärke, Metallbleche, Aluprofile von 3,0 - 18,0 mm, Kunststoffe / GFK und Profile von Ø 5,0 - 150,0 mm.

mm	mm	mm	Zahnteilung Zähne mm	Zahnteilung Zähne Zoll		
203,0	18,0	1,25	2,1 - 4,3	6 - 12 Tpi	331 89435	5





# Säbelsägeblätter für Maschinen von Bosch®, Metabo®, MP.S®, Wilpu®, Atlas Copco® / AEG® u. a.



Säbelsägeblätter anderer Hersteller \*  
Bosch® S 1022 HF | Metabo® 31932  
Wilpu® 3018-200 | MP.S® 4431

## RUKO 8909 HSS-Bimetall

Zahnung geschränkt und gefräst.

Verwendung für:  
Holz mit Nägeln und Metall von 5,0 - 150,0 mm Materialstärke, Metallbleche, Rohre, Aluprofile von 3,0 - 12,0 mm und Paletten.

mm	mm	mm	Zahnteilung Zähne mm	Zahnteilung Zähne Zoll		
203,0	18,0	0,9	2,5	10 Tpi	331 89095	5

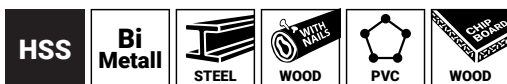

Säbelsägeblätter anderer Hersteller \*  
Bosch® S 1111 DF | AEG® 318-125

## RUKO 8936 HSS-Bimetall

Zahnung geschränkt und gefräst.

Verwendung für:  
Holz mit Nägeln und Metall, Spanplatten von 10,0 - 175,0 mm Materialstärke, Kunststoffprofile von Ø 5,0 - 175,0 mm, massive Kunststoffe / GFK von 8,0 - 50,0 mm.

mm	mm	mm	Zahnteilung Zähne mm	Zahnteilung Zähne Zoll		
228,0	18,0	1,25	4,25	6 Tpi	331 89365	5



Säbelsägeblätter anderer Hersteller \*  
Bosch® S 1122 HF

## RUKO 8945 HSS-Bimetall

Zahnung geschränkt und gefräst.

Verwendung für:  
Holz mit Nägeln und Metall von 5,0 - 175,0 mm Materialstärke, Metallbleche, Rohre, Aluprofile von 3,0 - 12,0 mm und für Palettenreparatur. Flexibler, bündiger Schnitt.

mm	mm	mm	Zahnteilung Zähne mm	Zahnteilung Zähne Zoll		
228,0	18,0	0,9	2,54	10 Tpi	331 89455	5



# Säbelsägeblätter für Maschinen von Bosch®, Metabo®, MP.S®, Wilpu®, Atlas Copco® / AEG® u. a.



Säbelsägeblätter anderer Hersteller \*  
Bosch® S 1125 VF | AEG® 323-813

## RUKO 8933 HSS-Bimetall

Zahnung geschränkt und gefräst.

Verwendung für:  
Holz mit Nägeln und Metall von 5,0 - 175,0 mm Materialstärke, Metallbleche, Aluprofile von 3,0 - 10,0 mm und Kunststoffprofile von Ø 3,0 - 175,0 mm.

mm	mm	mm	Zahnteilung Zähne mm	Zahnteilung Zähne Zoll		
228,0	18,0	1,25	1,8 - 2,6	10 - 14 Tpi	331 89335	5



Säbelsägeblätter anderer Hersteller \*  
Bosch® S 1122 VF | AEG® 323-813

## RUKO 8928 HSS-Bimetall

Zahnung geschränkt und gefräst.

Verwendung für:  
Holz mit Nägeln und Metall von 5,0 - 175,0 mm Materialstärke, Metallbleche, Aluprofile von 3,0 - 10,0 mm und Kunststoffprofile von Ø 3,0 - 175,0 mm. Flexibler, bündiger Schnitt.

mm	mm	mm	Zahnteilung Zähne mm	Zahnteilung Zähne Zoll		
228,0	18,0	0,9	1,8 - 2,6	10 - 14 Tpi	331 89285	5

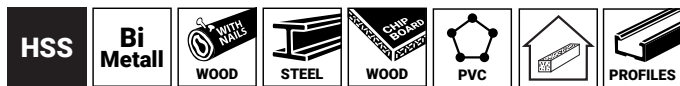

Säbelsägeblätter anderer Hersteller \*  
Bosch® S 1411 DF | Wilpu® 3021-300 bi

## RUKO 8937 HSS-Bimetall

Zahnung geschränkt und gefräst.

Verwendung für:  
Holz mit Nägeln, Metall und Spanplatten von 10,0 - 250,0 mm Materialstärke, Gasbeton von 10,0 - 250,0 mm, Kunststoffe / GFK und Profile von 5,0 - 60,0 mm.

mm	mm	mm	Zahnteilung Zähne mm	Zahnteilung Zähne Zoll		
305,0	18,0	1,25	4,2	6 Tpi	331 89375	5



# Säbelsägeblätter für Maschinen von Bosch®, Metabo®, MP.S®, Wilpu®, Atlas Copco® / AEG® u. a.



Säbelsägeblätter anderer Hersteller \*  
Bosch® S 1222 VF | Metabo® 31125 / 31475  
MP.S® 4432 | AEG® 354-778 | Wilpu® 3021/300 bi

## RUKO 8910 HSS-Bimetall

Zahnung geschränkt und gefräst.

Verwendung für:

Holz mit Nägeln und Metall von 5,0 - 250,0 mm Materialstärke, Metallbleche, Aluprofile von 3,0 - 10,0 mm und Kunststoffprofile von Ø 3,0 - 250,0 mm. Flexibler, bündiger Schnitt.

mm	mm	mm	Zahnteilung Zähne mm	Zahnteilung Zähne Zoll		
305,0	18,0	0,9	1,8 - 2,4	10 - 14 Tpi	331 89105	5



Säbelsägeblätter anderer Hersteller \*  
Bosch® S 1225 VF | Metabo® 31124 / 31474  
MP.S® 4422

## RUKO 8929 HSS-Bimetall

Zahnung geschränkt und gefräst.

Verwendung für:

Holz mit Nägeln und Metall von 5,0 - 250,0 mm Materialstärke, Metallbleche, Aluprofile von 3,0 - 10,0 mm und Kunststoffprofile von Ø 3,0 - 250,0 mm.

mm	mm	mm	Zahnteilung Zähne mm	Zahnteilung Zähne Zoll		
305,0	18,0	1,25	1,8 - 2,4	10 - 14 Tpi	331 89295	5



Säbelsägeblätter anderer Hersteller \*  
Bosch® S 617 K | Metabo® 28241  
MP.S® 4021 | Wilpu® 3019-150 | AEG® 354 779

## RUKO 8905 HCS

Zahnung geschränkt und gefräst.

Verwendung für:

Grobes und nagelfreies Holz von 20,0 - 100,0 mm, lebendes Holz, ausasten bis Ø 100,0 mm. Speziell für Kurven- und Tauchschnitte geeignet.

mm	mm	mm	Zahnteilung Zähne mm	Zahnteilung Zähne Zoll		
152,0	18,35	1,25	8,5	3 Tpi	331 89055	5



# Säbelsägeblätter für Maschinen von Bosch®, Metabo®, MP.S®, Wilpu®, Atlas Copco® / AEG® u. a.



Säbelsägeblätter anderer Hersteller \*  
Bosch® S 828 D | Metabo® 31136  
MPS® 4014/4060 | Wilpu® 3025-150 | AEG® 318-131

## RUKO 8903 HCS

Zahnung geschränkt.

Verwendung für:  
Speziell für verschiedene Gips- und Rigipsplatten von 8,0 - 100,0 mm. Holz, Eternit und Kunststoffe.

mm	mm	mm	Zahnteilung Zähne mm	Zahnteilung Zähne Zoll		
152,0	18,35	1,0	4,2	6 Tpi	331 89035	5

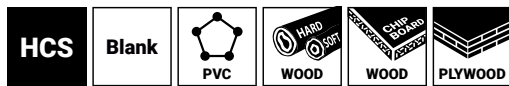

Säbelsägeblätter anderer Hersteller \*  
Bosch® S 644 D | Metabo® 31120 / 31470  
MPS® 4011/4012 | AEG® 323-800 | Wilpu® 3021-150

## RUKO 8924 HCS

Zahnung geschränkt und geschliffen.

Verwendung für:  
Konstruktionsholz, Sperrholz und Kunststoffe von 6,0 - 100,0 mm, Holzwand bis 75,0 mm, Spanplatten und MDF von 6,0 - 60,0 mm. Speziell für Tauchschnitte geeignet.

mm	mm	mm	Zahnteilung Zähne mm	Zahnteilung Zähne Zoll		
152,0	18,1	1,25	4,0	6 Tpi	331 89245	5



11



Säbelsägeblätter anderer Hersteller \*  
Bosch® S 2345 X | Metabo® 31910/31913  
MPS® 4046 | Wilpu® 3023/150-240

## RUKO 8944 HCS

Zahnung geschränkt und geschliffen.

Verwendung für:  
Konstruktionsholz, Sperrholz und Kunststoffe von 6,0 - 150,0 mm, Holzwand bis 175,0 mm, Spanplatten und MDF von 6,0 - 60,0 mm.

mm	mm	mm	Zahnteilung Zähne mm	Zahnteilung Zähne Zoll		
203,0	18,1	1,25	2,4 - 4,0	6 - 10 Tpi	331 89445	5



# Säbelsägeblätter für Maschinen von Bosch®, Metabo®, MP.S®, Wilpu®, Atlas Copco® / AEG® u. a.



Säbelsägeblätter anderer Hersteller \*  
Bosch® S 1111 K | Metabo® 31125 / 31475  
MP.S® 4432 | AEG® 354-778 | Wilpu® 3021/300 bi

## RUKO 8923 HCS

Zahnung geschränkt und gefräst.

Verwendung für:  
Grobes und nagelfreies Holz von 20,0 - 175,0 mm, Brennholz von Ø 20,0 - 175,0 mm.

mm	mm	mm	Zahnteilung Zähne mm	Zahnteilung Zähne Zoll		
225,0	18,0	1,25	8,5	3 Tpi	331 89235	5



Säbelsägeblätter anderer Hersteller \*  
Bosch® S 1531 L | Metabo® 31139 / 31488  
MP.S® 4052 | AEG® 323-803 | Wilpu® 3030-225

## RUKO 8922 HCS

Zahnung geschränkt und geschliffen.

Verwendung für:  
Grobes und nagelfreies Holz von 15,0 - 190,0 mm, lebendes Holz, ausasten bis Ø 190,0 mm,  
Brennholz von Ø 15,0 - 190,0 mm.

mm	mm	mm	Zahnteilung Zähne mm	Zahnteilung Zähne Zoll		
240,0	18,0	1,6	4,0 - 6,5	5 Tpi	331 89225	5



Säbelsägeblätter anderer Hersteller \*  
Bosch® S 1344 D | Metabo® 31122 / 31472  
MP.S® 4015 | AEG® 323-802 | Wilpu® 3021-300

## RUKO 8904 HCS

Zahnung geschränkt und geschliffen.

Verwendung für:  
Konstruktionsholz, Holzwand, Spanplatten, MDF, Sperrholz, Kunststoffe.

mm	mm	mm	Zahnteilung Zähne mm	Zahnteilung Zähne Zoll		
300,0	18,0	1,25	4,2	6 Tpi	331 89045	5



# Handsägeblatt HSS-Co Bihart cobalt



Dieses HSS-Bi-Metall Handsägeblatt besteht aus zwei verschiedenen Stählen. Die Schneiden bestehen aus hartem HSS-Molybdänstahl und der Sägeblattkörper besteht aus legiertem Vergütungsstahl. Durch die Kombination der beiden Stähle in einem Sägeblatt ist das Handsägeblatt äußerst verschleißfest, unzerbrechlich und besitzt eine hervorragende Schnittfähigkeit. Geeignet für alle gängigen Materialien.



Lieferbar: in 100 Stück pro Schachtel (10 x 10 Stück)

**!** Das ideale Blatt für gehobene Ansprüche.

mm	mm	mm	inch	inch	inch	Zahnteilung Zähne Zoll	Zahnteilung Zähne pro cm		
300,0	13,0	0,65	12	1/2	0.025	18 Tpi	8	3121 300 18 R	100
300,0	13,0	0,65	12	1/2	0.025	24 Tpi	10	3121 300 24 R	100
300,0	13,0	0,65	12	1/2	0.025	32 Tpi	12	3121 300 32 R	100

# Handsägeblatt HSS bi-flexible



Dieses HSS-Vollstahlsägeblatt vereint durch eine spezielle Wärmebehandlung zwei scheinbar unvereinbare Eigenschaften: Härte und Elastizität. Nur die Sägezähne sind gehärtet, der HSS-Sägeblattkörper bleibt flexibel. Durch diese zwei Härtezonen erhält das Handsägeblatt nahezu die Eigenschaften eines HSS-Bi-Metall Handsägeblattes.



Lieferbar: in 100 Stück pro Schachtel (10 x 10 Stück)

**!** Das ideale Blatt für Handwerker\*innen.





mm	mm	mm	inch	inch	inch	Zahnteilung Zähne Zoll	Zahnteilung Zähne pro cm		
300,0	13,0	0,65	12	1/2	0.025	18 Tpi	8	3181 300 18 R	100
300,0	13,0	0,65	12	1/2	0.025	24 Tpi	10	3181 300 24 R	100
300,0	13,0	0,65	12	1/2	0.025	32 Tpi	12	3181 300 32 R	100

11

## Sägebogen Kompakt 33

Griff aus lackiertem Leichtmetalldruckguss. Bogen aus verchromtem Vierkantröhr, poliert.  
Für Sägeblätter mit 300,0 mm Länge.  
Inklusive 1 Sägeblatt Bihart cobalt mit 24 Zähnen pro Zoll.



				
420,0	130,0	580 g	317 000 33 R	1

## Referenztablelle – für RUKO Säbelsägeblätter

Die technischen Daten der Sägeblätter anderer Hersteller können von unseren abweichen.

	Bosch®	D+N®	Gematic®	Hawera®	Metabo®	MPS®	Fein®	Alfra®
33189015	S 922 HF	11 10 18	11 5346	144248	31131	4430	48015	30 058
33189035	S 828 D	11 20 41	11 5222	121605	31136	4014 / 4060	56012	30 082
33189045	S 1344 D	11 20 46	11 5210	144235	31122 / 31472	4015	–	30 079
33189055	S 617 K	11 20 40	11 5207	121590	28241	4021	50011	30 076
33189065	S 922 AF	11 10 21	11 5354	144239	31129	4405	–	30 061
33189085	S 922 EF	11 10 20	11 5352	144242	31132	4401	–	30 060
33189095	S 1022 HF	11 10 24	11 5361	144249	31932	4431	52013	30 063
33189105	S 1222 VF	11 10 31	–	–	31125 / 31475	4432	–	30 071
33189135	S 1122 EF	11 10 26	11 5367	144243	31133 / 31483 / 31493	4402	59018	30 065
33189155	S 922 BF	11 10 19	11 5349	144245	31130	4411	47017	30 059
33189165	S 1122 BF	11 10 25	11 5364	–	31135 / 31485	4415	51010	30 064
33189175	S 611 DF	11 22 70	11 5328	–	31985	4016	–	–
33189185	S 1025 VF	–	–	–	31991	–	–	–
33189225	S 1531 L	11 20 51	11 5219	121611	31139 / 31488	4052	–	–
33189235	S 1111 K	–	–	–	–	–	–	–
33189245	S 644 D	11 20 44	11 5201	121600	31120 / 31470	4011	55019	–
33189285	S 1122 VF	11 10 35	–	–	–	–	–	–
33189295	S 1225 VF	11 10 32	11 5379	–	31124 / 31474	4422	–	–
33189335	S 1125 VF	11 10 34	–	–	–	–	–	–
33189365	S 1111 DF	11 22 71	–	–	–	–	–	–
33189375	S 1411 DF	11 22 72	–	–	–	–	–	–
33189405	S 123 XF	–	–	–	–	–	–	–
33189435	S 3456 XF	–	–	–	–	–	–	–
33189445	S 2345 X	–	–	–	31910 / 31913	4046	–	–
33189455	S 1122 HF	–	–	–	–	–	–	–
33189855	S 610 DF	–	–	–	–	–	–	–
33189865	S 920 CF	–	–	–	–	–	–	–
33189895	S 1120 CF	–	–	–	–	–	–	–



Flex®	Wilpu®	Atlas Copco® AEG®	Makita® Hitachi®	Milford® Rockwell®	Lenox®	Rothenberger®
–	3018-150	318-127	–	M 88176 / R12415	20562-610R	–
200.786	3025-150	318-131 / 323-801	M 0.30.20 / H 983 605 Z	M 87945	20560-606R	–
201.936	3021-300	318-125 / 323-802	M 0.30.21	M 88010 / R12403	20585-156R	–
200.751	3019-150	354-779	M 0.30.19	M 87936	–	–
200.743	3015-150	354-796	M 0.30.07 / H 983 603 Z	M 88179 / R 12433	20568-624R	86.5784
200.735	3014-150	354-792	M 0.30.06 / H 983 602 Z	M 88178 / R12454	20566-618R	86.5785
–	–	–	–	M 88174	20580-810R	–
201.928	3018-280	323-813	M 0.30.18	M 88208 / M 12418	–	–
217.751	3014-200	354-789	M 0.30.09	M 88187 / R 12420	20578-818R	86.5787
200.727	3013-150	323-810	M 0.30.13	M 88177 / M 12451	205654-614R	86.5786
217.190	3013-200	354-790	M 0.30.08 / H 983 601 Z	M 88186 / R 12419	–	86.5788
–	3021-150 bi	354-775	–	–	20570-636RP	–
–	–	–	–	–	–	–
250.056	3030-225	323-803	M 0.30.29	–	–	–
–	–	–	–	–	–	–
–	3021-150	318-126 / 323-800	–	M 88000 / R 12400	20572-656R	–
–	–	323-813	–	–	–	–
–	–	–	–	M 88218 / R 12457	20583-110R	86.5789
–	–	323-813	–	–	–	–
–	–	318-125	–	–	–	–
–	3021-300 bi	–	–	–	–	–
–	–	–	–	–	–	–
–	–	–	–	–	–	–
–	3023 / 150-240	–	–	–	–	–
–	–	–	–	–	–	–
–	3055-225	373-244	–	–	–	–
–	–	–	–	–	–	–
–	–	–	–	–	–	–



12



# ENTGRATER

Typen- und Anwendungsübersicht	290 – 291
Unigrat "Universalhandgriff"	292
Unigrat "Klingen B, C, E"	292 – 293
Unigrat "Stahlhalter"	293
Kantenentgrater mit HSS-Klingen	293
Schnellentgrater mit HSS-Klinge	294
Doppelentgrater mit HSS-Scheiben	294
Rohrentgrater mit HSS-Schneiden	294
Unigrat-Sätze	295

# Typen- und Anwendungsübersicht

	Werkstoff	Oberfläche	Typ	Bezeichnung	Materialstärke Werkstoff in mm	Verpackungseinheit	Art.-Nr.	Seite
	HSS	Blank	<b>B10</b>	Unigrat B 10		10	107 012	292
	HSS	Blank	<b>B20</b>	Unigrat B 20		10	107 014	
	HSS	Blank	<b>B30</b>	Unigrat B 30	4,0	10	107 015	
	TC HM	Blank	<b>B50</b>	Unigrat B 50		1	107 016	
	HSS	Blank	<b>B60</b>	Unigrat B 60	20,0	10	107 017	
	TC HM	Blank	<b>B70</b>	Unigrat B 70	3,0	1	107 018	
	HSS	Blank	<b>C40</b>	Unigrat C 40	4,0	1	107 020	
	HSS	Blank	<b>C42</b>	Unigrat C 42	8,0	1	107 021	
	HSS	Blank	<b>E100</b>	Unigrat E 100		10	107 026	293
	HSS	Blank	<b>E200</b>	Unigrat E 200		10	107 027	
	HSS	Blank	<b>E300</b>	Unigrat E 300	4,0	10	107 028	
	HSS	Blank	<b>E350</b>	Unigrat E 350		10	107 029	
	HSS	Blank	<b>E600</b>	Unigrat E 600	20,0	5	107 030	
	HSS	Blank		Rapid deburrer		1	107 052 107 054	294
	HSS	Blank		Double deburrer	10,0	1	107 060 107 061	
	HSS	Blank		Tube deburrer	∅ 4,0 – 36,0	1	107 053	

Rostfreier Stahl	Stahl	Blech	Gusseisen	Aluminium	Kupfer	Messing	Polyazetal	Polyamid (PA)	Polyvinylchlorid (PVC)	Polyphenyloxid	Polyethylen	Polypropylen	Polycarbonat	Polytetrafluoroethylen	Polystyrol
	●			●	●		●	○	●	●	●	●	●	●	●
			●			●	●	○	●	●	○	●	●	●	●
	●			●	●		●	●	●	●	●	●	●	●	○
○	●	●	●	●	●	●	●	●	●	●	●	●	●	●	○
	●			●	●		○	○	○	○	○	○	○	○	○
●	●	●		●	●	○	○		●	●			●		○
	●	○	○	○	●	○	○	○	○	○	○	○	○	○	○
	●	○	○	○	●	○	○	○	○	○	○	○	○	○	○
	●			●	●		●	○	●	●	●	●	●	●	●
			●			●	●	○	●	●	○	●	●	●	●
	●			●	●		●	●	●	●	●	●	●	●	○
			●			●									
	●			●	●		●	○	○	○	○	○	●	●	○
	●			●	●		●	○	●	●	●	●	●	●	●
○	●	○	○	●	●	○	○	○	○	○	○	○	○	○	○
○	●		○	●	●	○	●	○	●	●	●	●	●	○	●

## A Unigrat "Universalhandgriff"

In diesen Handgriff passen alle Halter B-C-D-E-F.

Die Stahlhalter können bei zurückgezogenem Arretierungskopf bis zu 100,0 mm in der Länge verstellt werden und sind in jeder Position feststellbar. Die Ersatzklingen passen in das abschraubbare Ende des Griffs.

Verpackung: Kunststoff

	L1 mm		
Universalhandgriff A	150,0	107 010	1



## B Unigrat "Klingen B"

Verpackung: Kunststoff

			
<b>B10</b>	Die am meisten verwendete HSS-Klinge für innere und äußere Entgratarbeiten an langspanenden Werkstoffen wie Stahl, Aluminium, Kunststoffe etc.	107 012	10
<b>B20</b>	Diese HSS-Klinge wird verwendet für kurzspanende Werkstoffe wie Messing und Gusseisen. Einsetzbar in beide Richtungen.	107 014	10
<b>B30</b>	Diese HSS-Klinge ist geeignet für gleichzeitiges Entgraten innerer und äußerer Bohrungen bis 4,0 mm Materialstärke.	107 015	10
<b>B50</b>	Reißnadel mit Hartmetallspitze, nachschleifbar.	107 016	1
<b>B60</b>	Diese HSS-Klinge entgratet Bohrungen rückseitig bis 20,0 mm Materialstärke.	107 017	10
<b>B70</b>	Diese Hartmetallklinge entgratet Werkstoffe bis zu 3,0 mm Materialstärke.	107 018	1



## C Unigrat "Klingen C"

Verpackung: Kunststoff

			
<b>C40</b>	Kleiner HSS-Dreikantschaber 4,0 x 20,0 mm für Präzisionsarbeiten bis 4,0 mm Flächenbreite.	107 020	1
<b>C42</b>	Großer HSS-Dreikantschaber 8,0 x 30,0 mm für Standardarbeiten bis 8,0 mm Flächenbreite.	107 021	1



## E Unigrat "Klingen E"

Verpackung: Kunststoff

			
<b>E100</b>	HSS-Klinge mit der Schneidkante von B 10, nur mit langem Schaft. Für innere und äußere Entgratarbeiten und langspanende Werkstoffe wie Stahl, Aluminium, Kunststoffe etc.	107 026	10
<b>E200</b>	HSS-Klinge mit der Schneidkante von B 20, nur mit langem Schaft. Für kurzspanende Werkstoffe wie Messing und Gußeisen. Einsetzbar in beide Richtungen.	107 027	10
<b>E300</b>	HSS-Klinge mit der Schneidkante von B 30, nur mit langem Schaft. Für gleichzeitiges Entgraten innerer und äußerer Bohrungen bis 4,0 mm Materialstärke.	107 028	10
<b>E350</b>	Diese HSS-Klinge ist geeignet zum Entgraten gerader Kanten, Keilnuten etc.	107 029	10
<b>E600</b>	Diese HSS-Klinge entgratet Bohrungen rückseitig bis 20,0 mm Materialstärke.	107 030	5

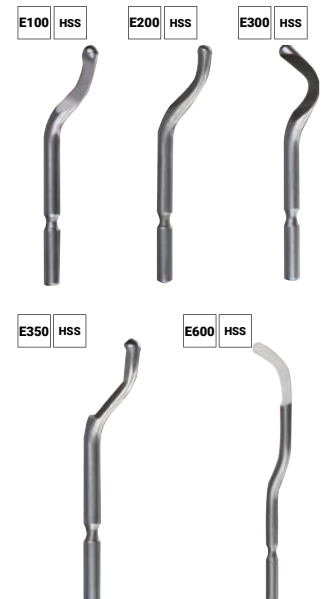

## Unigrat "Stahlhalter"

Verpackung: Kunststoff

			
Stahlhalter B		107 011	1
Stahlhalter C		107 019	1
Stahlhalter D		107 022	1
Stahlhalter E		107 025	1
Stahlhalter F		107 031	1



## Kantenentgrater mit HSS-Klingen

- Kunststoffgriff mit abschraubbarem Rückteil zur Aufbewahrung von Ersatzklingen.
- Klingen auswechselbar.
- Ideal zum Entgraten von Kanten, Rohren und Stahl-, Aluminium-, Messing-, Kupferblechen, Gusseisen und Kunststoffplatten.

Verpackung: Kunststoff

			
Kantenentgrater A1 komplett mit HSS-Klinge E 100		107 050	1
4-teiliger Kantenentgrater-Satz A3 komplett mit 3 HSS-Klingen		107 051	1



12

## Schnellentgrater mit HSS-Klinge

- Aluminium-Sechskantgriff.
- Klein und handlich.
- Ideal zum ständigen Mitführen.

Verpackung: SB-Tasche

		
Schnellentgrater mit nicht auswechselbarer HSS-Klinge E 100	107 052	1
Schnellentgrater mit auswechselbarer HSS-Klinge E 100	107 054	1



## Doppelentgrater mit HSS-Schneidscheiben

- Kunststoffgriff mit Handschutz und 2 Schneiden aus HSS.
- Auswechselbare Schneidscheiben aus HSS.
- Die Schneidscheiben können nach Abnutzung an den Schneidstellen weitergedreht und somit in vollem Umfang genutzt werden.
- Der Abstand der Schneidscheiben ist verstellbar.
- Zum beidseitigen Entgraten von Stahl-, Aluminium-, Messing-, Kupferblechen und Kunststoffplatten bis 10,0 mm geeignet.

Verpackung: Kunststoff

		
Doppelentgrater komplett	107 060	1
Ersatz-Schneidscheibe aus HSS	107 061	2

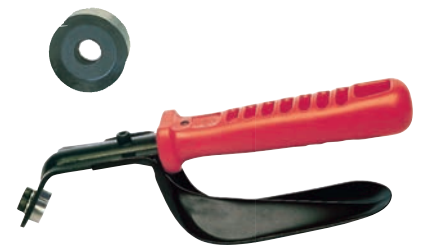

## 12 Rohrentgrater mit HSS-Schneiden

- Ideal zum Innen- und Außenentgraten von Rohren.
- Einsetzbar für Rohrdurchmesser von 4,0 bis 36,0 mm.

Verpackung: Kunststoff

		
Rohrentgrater	107 053	1







# Unigrat-Sätze

Ein rationelles Entgratsystem für alle Entgratarbeiten, die von Hand ausgeführt werden müssen. Durch die große Klingenauswahl haben Sie vielfache Möglichkeiten, Bohrungen und Kanten zu entgraten. Bei den verschiedenen Klingen können Sie Bohrungen von innen, außen oder beidseitig entgraten, da sich die Klinge selbst der Kontur anpasst.

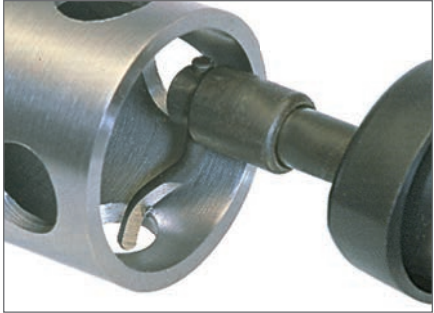
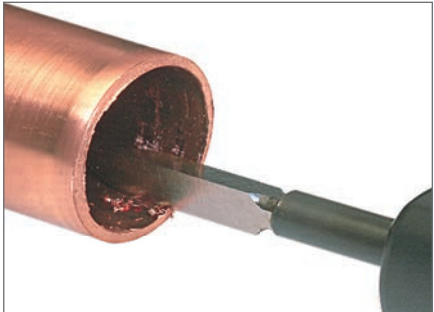
Verpackung: Kunststoff

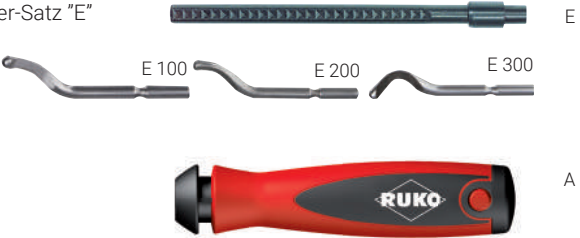
		
<p>4-teiliger Unigrat-Entgrater-Satz "B"</p> 	<p>107 003</p>	
<p>3-teiliger Unigrat-Entgrater-Satz "C"</p> 	<p>107 004</p>	
<p>5-teiliger Unigrat-Entgrater-Satz "E"</p> 	<p>107 006</p>	

13

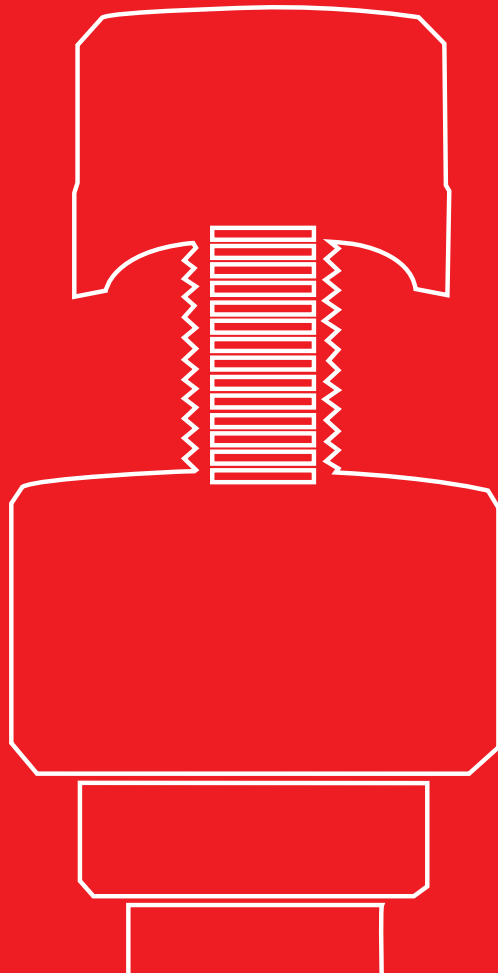

# SCHRAUBLOCHSTANZEN

Schraublochstanzen mit 3-Punkt-Anschnitt	298 – 299
Handhydraulikstanzen	300
Schraublochstanzen-Sätze mit kompakter Handhydraulikstanze	300
Ersatzteile	301
Richtwerte für den Einsatz von Schraublochstanzen	301



## Schraublochstanzen mit 3-Punkt-Anschnitt

Stempel: 3-Punkt-Anschnitt  
 Werkstoff: Spezialstahl  
 Zugschraube: metrisches Feingewinde

Geeignet für Stahlbleche, Edelstahlbleche, Bunt- und Leichtmetalle, Kunststoffe.  
 Ideal für Schaltanlagenbauer, Elektriker, Installateure, Industrie und Handwerk.



Das Durchgangsloch sollte nur geringfügig größer als der Durchmesser (+ 1,0 mm) der Zugschraube liegen. Die Schneidkanten und die Zugschraube mit RUKO Schmierpaste bestreichen. Das verringert den Verschleiß und erhöht somit die Lebensdauer der Schraublochstanze.

Verpackung: Karton

Ø mm	Durchgangsmaße		Conduit & Pipe Size	Ø Zoll	Zugschraube MF	Standard	Kugellager	
	M	PG						
12,7	M 12	PG 7		1/2"	MF 8	109 127		1
15,2		PG 9			MF 10	109 152	109 152 K	1
16,0					MF 10	109 160	109 160 K	1
16,5	M 16				MF 10	109 165	109 165 K	1
18,0					MF 10	109 180	109 180 K	1
18,6		PG 11			MF 10	109 186	109 186 K	1
19,0				3/4"	MF 10	109 190	109 190 K	1
20,0					MF 10	109 200	109 200 K	1
20,4	M 20	PG 13,5			MF 10	109 204	109 204 K	1
21,0					MF 10	109 210	109 210 K	1
22,0					MF 10	109 220	109 220 K	1
22,5		PG 16	1/2"	7/8"	MF 10	109 225	109 225 K	1
23,0					MF 10	109 230	109 230 K	1
24,0					MF 10	109 240	109 240 K	1
25,0					MF 10	109 250	109 250 K	1
25,4	M 25			1"	MF 10	109 254	109 254 K	1
26,0					MF 10	109 260	109 260 K	1
27,0					MF 10	109 270	109 270 K	1
28,3		PG 21	3/4"		MF 12	109 283	109 283 K	1
29,0					MF 12	109 290	109 290 K	1
30,0					MF 12	109 300	109 300 K	1
30,5				1 7/32"	MF 12	109 305	109 305 K	1
31,0					MF 12	109 310	109 310 K	1
32,0					MF 12	109 320	109 320 K	1
32,5	M 32				MF 12	109 325	109 325 K	1
33,0					MF 12	109 330	109 330 K	1
34,0					MF 12	109 340	109 340 K	1
35,0				1 3/8"	MF 12	109 350	109 350 K	1
36,0					MF 12	109 360	109 360 K	1
37,0		PG 29			MF 12	109 370	109 370 K	1
38,0				1 1/2"	MF 12	109 380	109 380 K	1
40,0	M 40				MF 12	109 400	109 400 K	1
40,5					MF 16	109 405	109 405 K	1
42,0					MF 16	109 420	109 420 K	1
43,0			1 1/4"		MF 16	109 430	109 430 K	1
45,0					MF 16	109 450	109 450 K	1
47,0		PG 36			MF 16	109 470	109 470 K	1
50,0			1 1/2"		MF 16	109 500	109 500 K	1
50,5	M 50				MF 16	109 505	109 505 K	1
51,0					MF 16	109 510	109 510 K	1
53,0					MF 16	109 530	109 530 K	1
54,0		PG 42		2 1/8"	MF 16	109 540	109 540 K	1
55,0					MF 16	109 550	109 550 K	1
60,0		PG ~ 48			MF 16	109 600	109 600 K	1
61,5			2"	2 3/8"	MF 16	109 615	109 615 K	1
63,5	M 63			2 1/2"	MF 16	109 635	109 635 K	1



		Standard	Kugellager
<b>4</b> Stk./pcs.	Schraublochstanzen-Satz 3 Schraublochstanzen Ø 28,3 (PG 21) - 32,0 - 35,0 + 1 Ersatzschraube MF 12 x 1,5 x 55	109 001	
<b>11</b> Stk./pcs.	Schraublochstanzen-Satz 6 Schraublochstanzen Ø 15,2 (PG 9) - 18,6 (PG 11) - 20,4 (M 20 / PG 13,5) - 22,5 (PG 16) - 28,3 (PG 21) + 32,0 mm  + 1 Blechschälbohrer HSS Gr. 1 + 1 Schneidpaste 20 ml + 2 Ersatzschrauben MF 10 x 1,0 + 1 Ersatzschraube MF 12 x 1,5	109 002	109 002 K
<b>13</b> Stk./pcs.	Schraublochstanzen-Satz 8 Schraublochstanzen Ø 15,2 (PG 9) - 18,6 (PG 11) - 20,4 (M 20 / PG 13,5) - 22,5 (PG 16) - 28,3 (PG 21) - 37,0 (PG 29) - 47,0 (PG 36) + 54,0 mm (PG 42)  + 1 Blechschälbohrer HSS Gr. 2 + 1 Schneidpaste 20 ml + 1 Ersatzschraube MF 10 x 1,0 + 1 Ersatzschraube MF 12 x 1,5 + 1 Ersatzschraube MF 16 x 1,5	109 003	109 003 K
<b>10</b> Stk./pcs.	Schraublochstanzen-Satz 5 Schraublochstanzen Ø 16,5 (M 16) - 20,4 (M 20 / PG 13,5) - 25,4 (M 25) - 32,5 (M 32) + 40,5 mm (M 40)  + 1 Blechschälbohrer HSS Gr. 2 + 1 Schneidpaste 20 ml + 1 Ersatzschraube MF 10 x 1,0 + 1 Ersatzschraube MF 12 x 1,5 + 1 Ersatzschraube MF 16 x 1,5	109 006	109 006 K
<b>12</b> Stk./pcs.	Schraublochstanzen-Satz 7 Schraublochstanzen Ø 16,5 (M 16) - 20,4 (M 20 / PG 13,5) - 25,4 (M 25) - 32,5 (M 32) - 40,5 (M 40) - 50,5 (M 50) + 63,5 mm (M 63)  + 1 Blechschälbohrer HSS Gr. 2 + 1 Schneidpaste 20 ml + 1 Ersatzschraube MF 10 x 1,0 + 1 Ersatzschraube MF 12 x 1,5 + 1 Ersatzschraube MF 16 x 1,5	109 008	109 008 K



109 001



109 003



109 006



109 008 K



13

# Handhydraulikstanzen

		
<b>5</b> tfg./pcs.	<p>Kompakte Handhydraulikstanze komplett</p> <p>1 kompakte Handhydraulikstanze komplett</p> <p>+ 1 Distanzbuchse</p> <p>+ 1 Adapterschraube MF 10 x 1,0 Aufnahme 3/4" UNF</p> <p>+ 1 Adapterschraube MF 12 x 1,5 Aufnahme 3/4" UNF</p> <p>+ 1 Adapterschraube MF 16 x 1,5 Aufnahme 3/4" UNF</p> <p>Zugkraft 50 kN</p>	109 101



## Schraublochstanzen-Sätze mit kompakter Handhydraulikstanze

		
<b>13</b> tfg./pcs.	<p>Schraublochstanzen-Satz mit kompakter Handhydraulikstanze</p> <p>1 kompakte Handhydraulikstanze komplett</p> <p>+ 6 Schraublochstanzen Ø 16,5 (M 16) - 20,4 (M 20 / PG 13,5) - 25,4 (M 25) - 32,5 (M 32) - 40,5 (M 40) + 50,5 mm (M 50)</p> <p>+ 1 Blechschälbohrer HSS Gr. 2</p> <p>+ 1 Schneidpaste 30 g</p> <p>+ 1 Distanzbuchse</p> <p>+ 1 Adapterschraube MF 10 x 1,0 Aufnahme 3/4" UNF</p> <p>+ 1 Adapterschraube MF 12 x 1,5 Aufnahme 3/4" UNF</p> <p>+ 1 Adapterschraube MF 16 x 1,5 Aufnahme 3/4" UNF</p> <p>Zugkraft 50 kN</p>	109 009
<b>15</b> tfg./pcs.	<p>Schraublochstanzen-Satz mit kompakter Handhydraulikstanze</p> <p>1 kompakte Handhydraulikstanze komplett</p> <p>+ 8 Schraublochstanzen Ø 15,2 (PG 9) - 18,6 (PG11) - 20,4 (M 20 / PG 13,5) - 22,5 (PG 16) - 28,3 (PG 21) - 37,0 (PG 29) - 47,0 (PG 36) + 54,0 mm (PG 42)</p> <p>+ 1 Blechschälbohrer HSS Gr. 2</p> <p>+ 1 Schneidpaste 30 g</p> <p>+ 1 Distanzbuchse</p> <p>+ 1 Adapterschraube MF 10 x 1,0 Aufnahme 3/4" UNF</p> <p>+ 1 Adapterschraube MF 12 x 1,5 Aufnahme 3/4" UNF</p> <p>+ 1 Adapterschraube MF 16 x 1,5 Aufnahme 3/4" UNF</p> <p>Zugkraft 50 kN</p>	109 004



# Ersatzteile

Die Adapterschrauben sind in allen gängigen Hydraulikstanzen einsetzbar.

Verpackung: Kunststoff

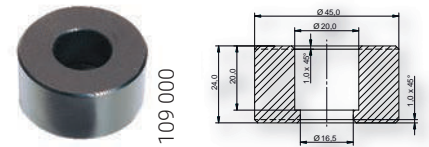

Distanzbuchse	109 000
Adapterschraube MF 10 x 1,0 Aufnahme 3/4" UNF	109 110
Adapterschraube MF 12 x 1,5 Aufnahme 3/4" UNF	109 112
Adapterschraube MF 16 x 1,5 Aufnahme 3/4" UNF	109 116
Ersatzschraube MF 8 x 1,0 x 40	103 108
Ersatzschraube MF 10 x 1,0 x 45	103 110
Ersatzschraube MF 12 x 1,5 x 55	103 112
Ersatzschraube MF 16 x 1,5 x 60	103 116
Ersatzschraube mit Kugellager MF 10 x 1,0 x 50	103 110 K
Ersatzschraube mit Kugellager MF 12 x 1,5 x 60	103 112 K
Ersatzschraube mit Kugellager MF 16 x 1,5 x 70	103 116 K



## Richtwerte für den Einsatz von Schraublochstanzen

Ø mm	Zugschraube	Stahlbleche	Edelstahlbleche	Bunt- und Leichtmetalle	Kunststoffe
12,7	MF 8 x 1,0 mm	2,0 mm	1,0 mm	4,0 mm	4,0 mm
15,2 - 27,0	MF 10 x 1,0 mm	2,0 mm	1,0 mm	4,0 mm	4,0 mm
28,3 - 40,0	MF 12 x 1,5 mm	3,0 mm	1,5 mm	4,0 mm	4,0 mm
40,5 - 63,5	MF 16 x 1,5 mm	3,0 mm	1,5 mm	4,0 mm	4,0 mm

# KÜHL- UND SCHMIERSTOFFE

14

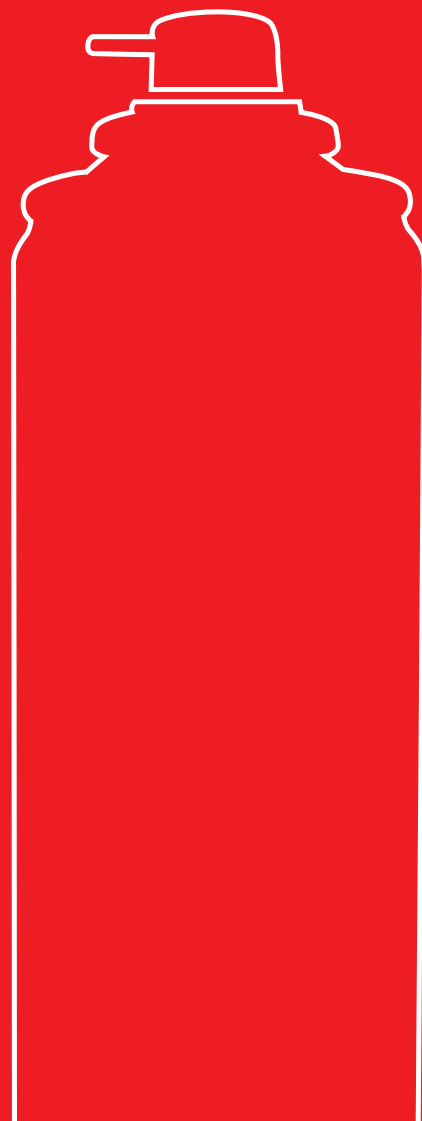



## Schneidpasten

Hochleistungsschneidpaste mit hervorragender Trenn- und Kühlwirkung. Erhöht die Werkzeugstandzeit auch bei harten und spröden Werkstoffen. Hohe Wärmebeständigkeit sorgt auch bei hohen Temperaturen für eine gute Schmierung und Kühlung. Gute Haftfähigkeit verbessert die Schmierung.

Für alle gängigen Metallbearbeitungsverfahren wie Gewindeschneiden, Reiben, Sägen, Bohren, Senken, Entgraten, Drehen, Stanzen und Fräsen. Schneidspray inklusive 360° Ventil!

		
Schneidpaste 40 ml	101 021	1
Schneidpaste 20 ml	101 035	1



## Schneidspraydosen

Hochleistungsschneidspray mit hervorragender Trenn- und Kühlwirkung. Erhöht die Werkzeugstandzeit auch bei harten und spröden Werkstoffen. Eine hohe Wärmebeständigkeit sorgt auch bei hohen Temperaturen für eine gute Schmierung und Kühlung. Die gute Haftfähigkeit verbessert die Schmierung.

Für alle gängigen Metallbearbeitungsverfahren wie Gewindeschneiden, Reiben, Sägen, Bohren, Senken, Entgraten, Drehen, Stanzen und Fräsen.

		
Schneidspraydose 50 ml	101 010	12
Schneidspraydose 200 ml	101 025	12
Schneidspraydose 400 ml	101 036	12
Schneidpumpspraydose * 300 ml	101 012	12

\* Kein Gefahrstoff (ohne Treibgas)



## Universalschneidöl-Konzentrat

Hervorragende Schmier- und Kühlwirkung. Verhindert Korrosion und erhöht die Werkzeugstandzeit durch ausgezeichnete Schmierfähigkeit, auch bei niedriger Konzentration. Transparente Lösung klebt nicht und ermöglicht unbehinderte Sicht auf Maschine, Werkstück sowie Werkzeug. Hautfreundlich, frei von Formaldehyd, Schwefel und Natriumnitrit, biostabil, entspricht TRGS 611.

Für alle gängigen Metallbearbeitungsverfahren in unlegierten und legierten Stählen, beim Gewindeschneiden, Reiben, Sägen, Bohren, Drehen, Fräsen und Schleifen. Bor- und Aminfrei. Anwendungskonzentration in Wasser je nach Arbeitsvorgang: 5 – 15 %

		
Schneidöl-Konzentrat 1 L Flasche	101 034	1
Schneidöl-Konzentrat 5 L Kanister	101 033	1



14



















**15**



# BETONBOHRER

Typen- und Anwendungsübersicht	306 – 307
SDS-plus Hammerbohrer mit 4 Schneiden	308
SDS-plus Hammerbohrer mit 2 Schneiden + Sätze	310 – 311
Universalbohrer mit Hartmetallschneide und Zylinderschaft	312
Glas- und Fliesenbohrer mit Hartmetallschneide und Zylinderschaft	312
Hammerfeste Schlagbohrkronen mit Hartmetallschneiden + Zubehör	313

# Typen- und Anwendungsübersicht

	Oberfläche	Schneiden	Schaft	Ø mm	Bohrtiefe in mm	Art.-Nr.	Seite/n
 	Blank			5,0 - 30,0	50 - 400	123 xxx 123 xxx K	308
	Blank			3,5 - 26,0	50,0 - 950,0	211 xxx	310 - 311
	Blank			5,0 - 12,0	50,0 - 90,0	223 xxx	312
	Blank			3,0 - 12,0	80,0 - 100,0	223 xxx	312
	Blank	 	 	30,0 - 100,0	50,0	226 xxx	313

Beton	Mauerwerk	Granit und Marmor	Fliesen	Ziegel	Leichtbaustoffe	Betonarmierung	Kunststoffe	Nichteisen, Alu	Glas
●	●	●	●	●		●			
●	●	●	●	●		●			
	●		●	●	●	●	●	●	
			●				●		●
●	●	●	●	●	●				



## SDS-plus Hammerbohrer mit 4 Schneiden

Durch eine besondere Bohrmehlmutgeometrie ist eine optimale Bohrmehlförderung gewährleistet. Reduzierte Vibrationen und wenig Reibung ergeben deutlich kürzere Bohrzeiten. Kernverstärkung für maximale Energieübertragung. Keine Bruchgefahr bei Armierungstreffern.

Einsatzgebiete: für Granit, Beton, Klinker, Stein, Mauerwerk und Marmor.



Verpackung: SB-Clip oder QuadroPack

Ø mm	Ø Zoll	L1 mm	L2 mm	SB-Clip		QuadroPack	
5,0	3/16	110 mm	50 mm	123 050	1	123 050 K	10
5,0	3/16	160 mm	100 mm	123 051	1	123 051 K	10
5,5	7/32	160 mm	100 mm	123 055	1	123 055 K	10
6,0	15/64	110 mm	50 mm	123 060	1	123 060 K	10
6,0	15/64	160 mm	100 mm	123 061	1	123 061 K	10
6,0	15/64	210 mm	150 mm	123 062	1	123 062 K	10
6,0	15/64	260 mm	200 mm	123 063	1	123 063 K	10
6,5	8/32	210 mm	150 mm	123 065	1	123 065 K	10
8,0	5/16	110 mm	50 mm	123 080	1	123 080 K	10
8,0	5/16	160 mm	100 mm	123 081	1	123 081 K	10
8,0	5/16	210 mm	150 mm	123 082	1	123 082 K	10
8,0	5/16	260 mm	200 mm	123 083	1	123 083 K	10
10,0	3/8	160 mm	100 mm	123 100	1	123 100 K	10
10,0	3/8	210 mm	150 mm	123 101	1	123 101 K	10
10,0	3/8	260 mm	200 mm	123 102	1	123 102 K	10
10,0	3/8	450 mm	400 mm	123 103	1	–	–
12,0	15/32	160 mm	100 mm	123 120	1	123 120 K	5
12,0	15/32	210 mm	150 mm	123 121	1	123 121 K	5
12,0	15/32	260 mm	200 mm	123 122	1	123 122 K	5
12,0	15/32	450 mm	400 mm	123 123	1	–	–
14,0	9/16	160 mm	100 mm	123 140	1	123 140 K	5
14,0	9/16	210 mm	150 mm	123 141	1	123 141 K	5
14,0	9/16	260 mm	200 mm	123 142	1	123 142 K	5
14,0	9/16	450 mm	400 mm	123 143	1	123 143 K	5
16,0	5/8	210 mm	150 mm	123 161	1	–	–
16,0	5/8	260 mm	200 mm	123 162	1	–	–
16,0	5/8	310 mm	250 mm	123 163	1	–	–
16,0	5/8	450 mm	400 mm	123 164	1	–	–
18,0	11/16	260 mm	200 mm	123 181	1	–	–
18,0	11/16	450 mm	400 mm	123 182	1	–	–
20,0	25/32	260 mm	200 mm	123 201	1	–	–
20,0	25/32	450 mm	400 mm	123 202	1	–	–
22,0	7/8	450 mm	400 mm	123 221	1	–	–
24,0	15/16	450 mm	400 mm	123 241	1	–	–
28,0	1 1/8	450 mm	400 mm	123 281	1	–	–
30,0	1 3/16	450 mm	400 mm	123 301	1	–	–





## SDS-plus Hammerbohrer mit 2 Schneiden

Höhere Lebensdauer in Beton und auf Armierung dank stabilisierter Kopfgeometrie und abgerundeten Schneidkanten. Patentiertes 2-Schneiden-Design nach dem Bionic-Prinzip. Innovatives Twinmax-3D-Wendelprofil ermöglicht einen optimalen Bohrmehltransport. Zertifiziert durch die Prüfgemeinschaft Mauerbohrer (PGM) nach Anforderung des Deutschen Instituts für Bautechnik (DiBt).

Einsatzgebiete: für Granit, Beton, Betonarmierung, Klinker, Stein, Mauerwerk und Marmor.  
Einsatz: In allen Bohrhämmern mit SDS-plus-Aufnahme und 2-Nut-Aufnahme wie z. B. Hilti TE 10-22.

Verpackung: SB-Clip

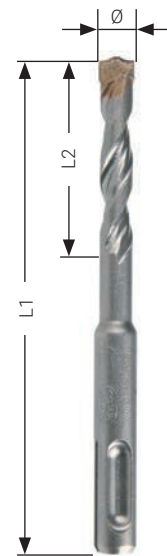

Ø mm	Ø Zoll	L1 mm	L2 mm		
3,5	9/64	110,0	50,0	211 035	1
4,0	5/32	110,0	50,0	211 040	1
4,0	5/32	160,0	100,0	211 041	1
5,0	3/16	110,0	50,0	211 050	1
5,0	3/16	160,0	100,0	211 051	1
5,0	3/16	210,0	150,0	211 052	1
5,5	7/32	110,0	50,0	211 055	1
5,5	7/32	160,0	100,0	211 056	1
6,0	15/64	110,0	50,0	211 060	1
6,0	15/64	160,0	100,0	211 061	1
6,0	15/64	210,0	150,0	211 062	1
6,0	15/64	260,0	200,0	211 063	1
6,0	15/64	460,0	* 400,0	211 068	1
6,5	8/32	110,0	50,0	211 065	1
6,5	8/32	160,0	100,0	211 066	1
6,5	8/32	210,0	150,0	211 067	1
6,5	8/32	260,0	200,0	211 069	1
7,0	9/32	110,0	50,0	211 070	1
7,0	9/32	160,0	100,0	211 071	1
7,0	9/32	210,0	150,0	211 072	1
8,0	5/16	110,0	50,0	211 080	1
8,0	5/16	160,0	100,0	211 081	1
8,0	5/16	210,0	150,0	211 082	1
8,0	5/16	260,0	200,0	211 083	1
8,0	5/16	310,0	250,0	211 085	1
8,0	5/16	460,0	* 400,0	211 084	1
8,0	5/16	610,0	* 550,0	211 086	1
9,0	11/32	160,0	100,0	211 090	1
9,0	11/32	210,0	150,0	211 091	1
10,0	3/8	110,0	50,0	211 105	1
10,0	3/8	160,0	100,0	211 100	1
10,0	3/8	210,0	150,0	211 101	1
10,0	3/8	260,0	200,0	211 102	1
10,0	3/8	310,0	250,0	211 104	1
10,0	3/8	360,0	300,0	211 103	1
10,0	3/8	460,0	* 400,0	211 106	1
10,0	3/8	610,0	* 550,0	211 107	1
10,0	3/8	1000,0	* 950,0	211 108	1
11,0	7/16	160,0	100,0	211 110	1
11,0	7/16	210,0	150,0	211 111	1
11,0	7/16	260,0	200,0	211 112	1
12,0	15/32	160,0	100,0	211 120	1
12,0	15/32	210,0	150,0	211 122	1
12,0	15/32	260,0	200,0	211 121	1
12,0	15/32	310,0	250,0	211 124	1
12,0	15/32	460,0	* 400,0	211 123	1
12,0	15/32	600,0	* 550,0	211 125	1
12,0	15/32	1000,0	* 950,0	211 126	1
13,0	1/2	160,0	100,0	211 130	1

Ø mm	Ø Zoll	L1 mm	L2 mm		
13,0	1/2	210,0	150,0	211 133	1
13,0	1/2	260,0	200,0	211 131	1
13,0	1/2	310,0	250,0	211 132	1
14,0	9/16	160,0	100,0	211 140	1
14,0	9/16	210,0	150,0	211 141	1
14,0	9/16	260,0	200,0	211 142	1
14,0	9/16	310,0	250,0	211 143	1
14,0	9/16	460,0	* 400,0	211 144	1
14,0	9/16	600,0	* 550,0	211 145	1
14,0	9/16	1000,0	* 950,0	211 146	1
15,0	19/32	160,0	100,0	211 150	1
15,0	19/32	210,0	150,0	211 152	1
15,0	19/32	260,0	200,0	211 151	1
15,0	19/32	450,0	* 400,0	211 153	1
16,0	5/8	160,0	100,0	211 162	1
16,0	5/8	210,0	150,0	211 160	1
16,0	5/8	250,0	200,0	211 163	1
16,0	5/8	310,0	250,0	211 164	1
16,0	5/8	450,0	* 400,0	211 161	1
16,0	5/8	600,0	* 550,0	211 165	1
16,0	5/8	800,0	* 750,0	211 166	1
16,0	5/8	1000,0	* 950,0	211 167	1
17,0	43/64	210,0	150,0	211 170	1
18,0	11/16	200,0	150,0	211 180	1
18,0	11/16	250,0	200,0	211 184	1
18,0	11/16	300,0	250,0	211 183	1
18,0	11/16	450,0	* 400,0	211 181	1
18,0	11/16	600,0	* 550,0	211 185	1
18,0	11/16	1000,0	* 950,0	211 182	1
19,0	3/4	200,0	150,0	211 190	1
19,0	3/4	450,0	* 400,0	211 191	1
20,0	25/32	200,0	150,0	211 200	1
20,0	25/32	300,0	250,0	211 201	1
20,0	25/32	450,0	* 400,0	211 202	1
20,0	25/32	600,0	* 550,0	211 203	1
20,0	25/32	1000,0	* 950,0	211 204	1
22,0	7/8	250,0	200,0	211 221	1
22,0	7/8	300,0	250,0	211 222	1
22,0	7/8	450,0	* 400,0	211 220	1
22,0	7/8	600,0	* 550,0	211 223	1
22,0	7/8	1000,0	* 950,0	211 224	1
24,0	15/16	250,0	200,0	211 240	1
24,0	15/16	450,0	* 400,0	211 241	1
25,0	63/64	250,0	200,0	211 251	1
25,0	63/64	300,0	250,0	211 252	1
25,0	63/64	450,0	* 400,0	211 250	1
25,0	63/64	1000,0	* 950,0	211 253	1
26,0	1 3/16	250,0	200,0	211 261	1
26,0	1 3/16	450,0	* 400,0	211 260	1

\* Mit kürzerem Hammerbohrer gleichen Durchmessers ca. 150,0 mm tief vorbohren.



Verpackung: Kunststoff

Ø mm	Ø Zoll	L1 mm	L2 mm		
5,0	3/16	110,0	50,0	211 050 K	10
5,0	3/16	160,0	100,0	211 051 K	10
6,0	15/64	110,0	50,0	211 060 K	10
6,0	15/64	160,0	100,0	211 061 K	10
8,0	5/16	110,0	50,0	211 080 K	10
8,0	5/16	160,0	100,0	211 081 K	10
8,0	5/16	210,0	150,0	211 082 K	10
10,0	3/8	110,0	50,0	211 105 K	10
10,0	3/8	160,0	100,0	211 100 K	10
12,0	15/32	160,0	100,0	211 120 K	10
12,0	15/32	210,0	150,0	211 122 K	10
14,0	9/16	160,0	100,0	211 140 K	5
14,0	9/16	210,0	150,0	211 141 K	5



		
<b>7</b> Stk./Pcs.	SDS-plus Hammerbohrer-Satz Ø 5,0 - 6,0 - 8,0 x 110,0 mm und Ø 6,0 - 8,0 - 10,0 - 12,0 x 160,0 mm	205 246 RO



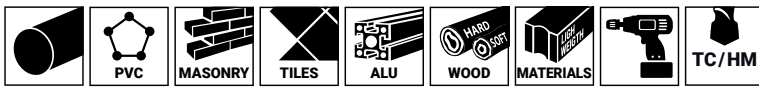

## Universalbohrer mit Hartmetallschneide und Zylinderschaft

Extreme Standzeiten durch speziell legierte Stahlqualität. Spezial-Hartmetallplatte mit Zentrumspitze. Für punktgenaues Anbohren auf harten Oberflächen. Ideal für splitterfreies und präzises Bohren.

Einsatzgebiete: für Wandfliesen, Klinker, Stein, Mauerwerk, Kunststoffe, NE-Metalle, Weich-, Hartholz und Leichtbaustoffe. Nur im drehenden Einsatz in Dreh- und Schlagbohrmaschinen verwendbar. Ideal auch für Akku-Bohrmaschinen.

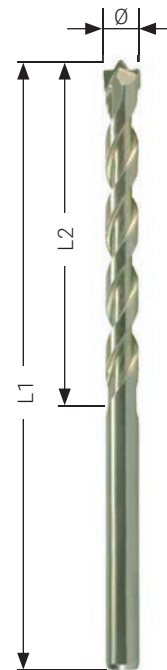

Verpackung: SB-Tasche

Ø mm	Ø Zoll	L1 mm	L2 mm		
5,0	3/16	95,0	50,0	223 050	1
6,0	15/64	100,0	60,0	223 060	1
8,0	5/16	120,0	80,0	223 080	1
10,0	3/8	120,0	80,0	223 100	1
12,0	15/32	150,0	90,0	223 120	1



## Glas- und Fliesenbohrer mit Hartmetallschneide und Zylinderschaft

Beste Ergebnisse bei niedrigen Drehzahlen und guter Kühlung mit Wasser, Essig, Terpentin oder Petroleum. Speziell geeignet zum Bohren von Glasscheiben, Spiegelglas, Flaschen, Porzellan, Fliesen, Keramik usw.

Schneide: Spezial-Hartmetallplatte geschliffen  
Lötung: hochfeste Speziallötung

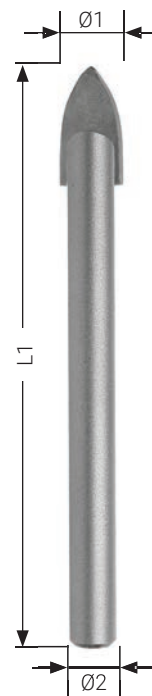

Verpackung: SB-Tasche

Ø1 mm	Ø1 Zoll	Ø2 mm	L1 mm		
3,0	1/8	3,0	80,0	223 003	1
4,0	5/32	3,0	90,0	223 004	1
5,0	3/16	4,0	90,0	223 005	1
6,0	15/64	5,0	100,0	223 006	1
8,0	5/16	6,0	100,0	223 008	1
10,0	3/8	6,0	120,0	223 010	1
12,0	15/32	8,0	120,0	223 012	1



## Hammerfeste Schlagbohrkronen mit Hartmetallschneiden

Hoher Leistungsgrad durch sehr stabilen und dünnwandigen Bohrkronenkörper.

Einsatzgebiete: für Beton, Stein, Mauerwerk und Ziegel.  
Einsatz: in Bohrhammern bis max. 4,0 kg mit SDS-plus-Aufnahme und 2-Nut-Aufnahme.  
In Schlagbohrmaschinen mit Sechskantschaft.

Erforderliche Maschinenleistung: bis  $\varnothing$  50,0 mm min. 600 Watt ab,  $\varnothing$  65,0 mm min. 800 Watt.  
Lieferung ohne Zentrierbohrer und Aufnahmeschaft.



Schneiden: bohrhammerfeste Spezial-Hartmetallplatten in Sonderlegierung  
Lötung: hochfeste Speziallötung  
Aufnahme: Gewinde M16



Verpackung: Kunststoff

Einsatzbeispiele	$\varnothing$ mm	L1 mm	Bohrtiefe L2 mm	Zähnezahl HM		
Sanitär und Heizungsrohre	30,0	72,0	50,0	4	226 0301	1
Sanitär und Heizungsrohre	35,0	72,0	50,0	4	226 0351	1
Ablauf-, Wasser- und Heizungsrohre mit Isolierung	40,0	72,0	50,0	4	226 0401	1
Ablauf-, Wasser- und Heizungsrohre mit Isolierung	50,0	72,0	50,0	6	226 0501	1
Schaltdosen	68,0	72,0	50,0	6	226 0651	1
Abzweig- und Verteilerdosen	82,0	72,0	50,0	6	226 0801	1
Abzweig-, Verteilerdosen und Lüftungsrohre	90,0	72,0	50,0	6	226 0901	1
Lüftungsrohre	100,0	72,0	50,0	6	226 1001	1













## Zubehör für Schlagbohrkronen

Zentrierbohrer mit Hartmetallschneiden $\varnothing$ 8,0 mm, Gesamtlänge 120,0 mm	226 200	1
Aufnahmeschaft mit Sechskant Schlüsselweite 12,0 mm, Gesamtlänge 95,0 mm	226 201	1
Aufnahmeschaft SDS-plus, Gesamtlänge 110,0 mm	226 203	1

















# Übersicht der Symbole

## 01 Spiralbohrer

 <b>HSS</b> Schnellarbeitsstahl	 <b>HSS-R</b> Schnellarbeitsstahl rollgewalzt	 <b>19</b> tlg./pcs. Satzware z. B. 19-teilig
 <b>HSSE Co8</b> Schnellarbeitsstahl mit 8 % Cobaltanteil	 <b>HSSE Co5</b> Schnellarbeitsstahl mit 5 % Cobaltanteil	 <b>Inch Size</b> Zollabmessungen
 <b>Blank</b> Blanke Oberfläche	 <b>VAP Bonze</b> Schwarzoxidierte / Bronzefarbene Oberfläche	 <b>TiAlN</b> TiAlN Beschichtung
 <b>Bronze</b> Bronzefarbene Oberfläche	 <b>VAP Blank</b> Schwarzoxidierte / Blanke Oberfläche	 linksschneidend
 <b>VAP</b> Schwarzoxidierte Oberfläche	 <b>TiN</b> TiN Beschichtung	 Bohrtiefe z. B. 5 x Ø
 Spitzenwinkel z. B. 130°	 Spiralwinkel z. B. 40°	 Abgesetzter Schaft
 <b>h8</b> Toleranz h8	 Zylinderschaft	 Morsekegelschaft
 Dreiflächenschaft z. B. ab Ø 4,0 mm	 Weldonschaft	 Vierkantschaft nach DIN 10
 <b>FLOW STEP TIP</b> FLOWSTEP® Spitze ab Ø 3,0 mm	 Sehr gut geeignet für den Einsatz in Handbohrmaschinen und Akku- Bohrschraubern	 Durchgangslochbohrung
 Senkwinkel 60°		

## 02 Spezialbohrer

 <b>HSS</b> Schnellarbeitsstahl	 <b>HSSE Co5</b> Schnellarbeitsstahl mit 5 % Cobaltanteil	 <b>TC HM</b> Hartmetall
 <b>Blank</b> Blanke Oberfläche	 <b>TiN</b> TiN Beschichtung	 <b>AlTiN</b> AlTiN Beschichtung
 <b>TiCN</b> TiCN Beschichtung	 <b>E</b> Zentrumspitze	 Spitzenwinkel 180°
 <b>N</b> Form N Kegelmantelanschliff Normalanschliff	 <b>h8</b> Toleranz h8	 <b>13</b> tlg./pcs. Satzware z. B. 13-teilig
 Spiralwinkel z. B. 25 – 30°	 Sehr gut geeignet für den Einsatz in Handbohrmaschinen und Akku- Bohrschraubern	 Zylinderschaft

## 03 Blechschräbbohrer



Schnellarbeitsstahl



Kegelwinkel  
z. B. 20 – 30°



Ø Toleranz  
Werksnorm



Bit-Schaft  
1/4" x 27,0 mm



Schnellarbeitsstahl  
mit 5 % Cobaltanteil



Spitzenwinkel  
z. B. 118°



Spitzenanschliff  
Werksnorm



TiN Beschichtung



Form C:  
Kreuzanschliff



Dreiflächenschaft

## 04 Stufenbohrer



Schnellarbeitsstahl



Blanke Oberfläche



Form C:  
Kreuzanschliff



Spitzenwinkel  
z. B. 118°



Dreiflächenschaft



4 Schneiden



Schwarzoxidierte Oberfläche



FLOWSTEP® Spitze  
ab Ø 3,0 mm



Schnellarbeitsstahl  
mit 5 % Cobaltanteil



TiN Beschichtung



Stufenwinkel  
z. B. 90°



Spitzenanschliff  
Werksnorm



Bit-Schaft  
1/4" x 27,0 mm



3 Schneiden



RUKO Turbo Spitze



TiAlN Beschichtung



RUnaTEC  
Beschichtung



FLOWSTEP® Technologie



Ø Toleranz  
Werksnorm



Zylinderschaft



Materialstärke bis max.  
z. B. 4 mm



Satzware  
3-teilig

## 05 Senker



Schnellarbeitsstahl



Schnellarbeitsstahl  
mit 5 % Cobaltanteil



Hartmetall



Senkwinkel  
z. B. 90°



Blanke Oberfläche



Schwarzoxidierte Oberfläche



RUnaTEC  
Beschichtung



3 Schneiden



TiAlN Beschichtung



TiN Beschichtung



Für Aluminium



Kegelmantelschliff  
Normalanschliff



Spitzenwinkel 120°



Morsekegel



Bit-Schaft  
1/4" x 27,0 mm



Sehr gut geeignet für den Einsatz in  
Handbohrmaschinen und Akku-  
Bohrschraubern



Zylinderschaft  
bei Senk-Ø 6,3 mm



Satzware  
z. B. 6-teilig



1 Schneide



Zylinderschaft



schnelle Schnitte



Senkwinkel 180°



Sehr gut geeignet für den Einsatz in  
Ständerbohrmaschinen



Zollabmessungen



Toleranz h8



Dreiflächenschaft



4 ungleichgeteilte Schneiden



Dreiflächenschaft  
ab Senk-Ø 8,3 mm



Sehr gut geeignet für den Einsatz in  
CNC-Drehmaschinen

## 06 Gewindebohrwerkzeuge



Schnellarbeitsstahl



Schnellarbeitsstahl  
mit 5 % Cobaltanteil



linksschneidend



FLOWSTEP® Spitze



Sacklochbohrung



metrisches ISO-Regelgewinde  
DIN 13



metrisches ISO-Feingewinde  
DIN 13



British-Standard-Whitworth-Gewinde  
nach BS 84



British-Standard-Fein-Gewinde  
nach BS 84



DIN ISO 228 "G"  
(zylindrisches Rohrgewinde)



Blanke Oberfläche



Schwarzoxidierte Oberfläche



Form B ca. 4 – 5 Gänge  
mit Schälanschnitt



Form C / 35° RSP Rechtsspiralnute  
ca. 2 – 3 Gänge



Form D  
ca. 4 – 6 Gänge



Ausgesetzte Gewindezähne  
zur Bearbeitung von weichen  
Werkstoffen



Durchgangslochbohrung



Amerikanisches Grobgewinde  
nach ANSI / ASME B 1.1



Amerikanisches Feingewinde  
nach ANSI / ASME B 1.1



Amerikanisches kegeliges  
Rohrgewinde nach B 1.20.1



DIN 2999 "Rp"  
Whitworth Rohrgewinde



Stahlpanzerrohr-Gewinde  
nach DIN 40430



TiAlN Beschichtung



TiN Beschichtung



Amerikanische Gewindetoleranz  
zum Herstellen von Innengewinden



Amerikanische Gewindetoleranz  
zum Herstellen von Außengewinden



Gewinde-Toleranz für metrisch  
und metrisch-feine Gewinde nach  
DIN ISO 13 – Innengewinde



Gewinde-Toleranz für metrisch  
und metrisch-feine Gewinde nach  
DIN ISO 13 – Außengewinde



Ø Toleranz  
Werksnorm



Maschinengewindebohrer  
mit verstärktem Schaft



Maschinengewindebohrer  
mit Überlaufschaft



Festigkeitsklassen  
z. B. 800 N/mm<sup>2</sup>



Flankenwinkel  
z. B. 60°



Bit-Schaft  
1/4" x 27,0 mm



Vierkantschaft nach DIN 10



Metrisches ISO-Gewinde  
nach DIN 13



Zylinderschaft



Bohrtiefe  
z. B. 5 x Ø



Form C:  
Kreuzanschliff ab Ø 2 mm



Spitzenwinkel  
z. B. 130°



Spiralwinkel  
z. B. 36°



Toleranz h8



Sehr gut geeignet für den Einsatz in  
Handbohrmaschinen und Akku-  
Bohrschraubern



Farbring  
z. B. grün



Satzware  
z. B. 7-teilig

## 07 Gewindereparaturwerkzeuge



Schnellarbeitsstahl



Form C: Kreuzanschliff



Vierkantschaft nach DIN 10



metrisches ISO-Regelgewinde  
DIN 13



Form B ca. 4 – 5 Gänge  
mit Schälanschnitt



Zylinderschaft



Typ N



Flankenwinkel  
z. B. 60°



Spitzenwinkel 118°



Bohrtiefe  
5 x Ø



Gewinde-Toleranz für metrisch und  
metrisch-feine Gewinde nach DIN ISO  
13 - Innengewinde



Spiralwinkel 25 – 30°



Toleranz z. B. h8



Satzware  
z. B. 86-teilig

## 08 Kernbohrtechnik



Schnellarbeitsstahl



Blanke Oberfläche



Weldonschaft



Schnellarbeitsstahl  
mit 5 % Cobaltanteil



TiAlN Beschichtung



Quick IN-Schaft



Vollhartmetall



Bohrtiefe  
z. B. 30,0 mm



Gewindeaufnahme



Ø Toleranz  
Werksnorm



Geeignet für den Einsatz in  
Magnetbohrmaschinen



Geeignet für den Einsatz in Ständer-  
bohrmaschinen



Geeignet für den Einsatz in den  
RUKO Magnetbohrmaschinen  
RU40, RU25 und A10



Satzware  
z. B. 9-teilig

## 09 Frässtifte



Hartmetall



Zylinderschaft



Satzware  
z. B. 12-teilig



Blanke Oberfläche



Zahnung CT 4  
für Stähle



TiCN Beschichtung



Zahnung ALU  
für weiche Werkstoffe

## 10 Lochsägen



Schnellarbeitsstahl



Schnellarbeitsstahl  
mit 8 % Cobaltanteil



Hartmetall



Satzware  
z. B. 8-teilig



Schneiden aus Schnellarbeitsstahl  
mit 8 % Cobaltanteil



Materialstärke bis max. 2,5 mm



Blanke Oberfläche



Bimetall



Dreiflächenschaft



Schneidenwinkel  
Werksnorm



Schneiden aus Schnellarbeitsstahl



Materialstärke bis max. 28 mm  
für Buntmetalle



Zähne pro Zoll  
z. B. 6 Zähne



Variable Zahnung



Feinverzahnung



Schnitttiefe  
z. B. 10,0 mm



Schneiden aus Hartmetall



Materialstärke bis max. 20 mm  
für Inox

## 11 Sägen



Blanke Oberfläche



Stahl mit  
hohem Kohlenstoffgehalt



Baustahl



Bleche



Inox



Aluminium



Buntmetalle



Schnellarbeitsstahl



Oberfläche weiß



Eternit-Platten



Hart- und Weichhölzer



Spanplatten



Tischlerplatten



Sandwich-Material



Bimetall



Schwarze Oberfläche



Rohre



Kurvenschnitte



Sperrholz



rechtwinklige Schnitte



Baumschnitte





Holz mit Nägeln



Profile



beschichtete Platten



Kunststoffe



Gasbeton



besondere Technik



schnelle Schnitte

## 12 Entgrater



Schnellarbeitsstahl



Hartmetall



Blanke Oberfläche

## 13 Schraublochstanzen



Schwarzoxidierte Oberfläche



metrisches ISO-Feingewinde  
DIN 13



Materialstärke bis max.  
z. B. 4,0 mm



3 Schneiden



Satzware  
z. B. 5-teilig

## 15 Betonbohrer



Blank surface



Tungsten carbide



Nichteisen



Spitzenwinkel 130°



Zylinderschaft



Kunststoffe



Bohrer-/Schnitttiefe 50,0 mm



Sechskantschaft



Glas



4 Schneiden



2 Schneiden



6 Schneiden



SDS-plus-Schaft



ISO 5468



Mauerwerk



Holz



DIN 8039



Granit und Marmor



Fliesen



Beton



Leichtbaustoffe



Hart- und Weichhölzer



Ziegel



Sehr gut geeignet für den Einsatz in  
Handbohrmaschinen und Akku-  
Bohrschraubern



Schneiden aus Hartmetall



Satzware  
7-teilig

# Artikelnummernverzeichnis

Artikel-Nr.		Seite/n
101 001	- 101 022	68
101 001 E	- 101 008 E	68
101 001 T	- 101 008 T	68
101 010	- 101 036	303
101 020 RO / TRO / ERO		68
101 026 RO / ERO / TRO / FRO		83
101 049 H		69
101 050-5	- 101 097	82
101 050-5 F	- 101 097 F	82
101 050-5 T	- 101 097 T	82
101 050-9 E	- 101 534 E	82
101 050-9 H	- 101 052 H	84
101 050-9 TH	- 101 052 TH	84
101 061	- 101 063	84
101 061 T	- 101 063 T	84
101 068 F-1		83
101 090	- 101 093	87
101 090 F	- 101 093 F	87
101 090 T	- 101 093 T	87
101 101	- 101 104	62
101 104 HM		62
101 107	- 101 114	63
101 107 HM	- 101 108 HM	63
101 107 TC	- 101 114 TC	63
101 201	- 101 202	63
101 201 T	- 101 202 T	63
101 326 RO	+ 101 326 TRO	86
101 350-9	- 101 352	86
101 350-9 T	- 101 352 T	86
101 626 ERO	+ 101 626 EPRO	80
101 626 RO	+ 101 626 PRO	81
101 631	- 101 363	87
101 650-9	- 101 653	81
101 650-9 E	- 101 653 E	80
101 650-9 EP	- 101 653 EP	80
101 650-9 P	- 101 653 P	81
101 701	- 101 709	85
101 701 E	- 101 709 E	85
101 701 F	- 101 709 F	85
101 701 T	- 101 709 T	85
102 101	- 102 174	110
102 101 E	- 102 125 E	108
102 101 F	- 102 174 F	108
102 101 T	- 102 174 T	110
102 107 A	- 102 125 A	110
102 126	- 102 141	113
102 142 / A / T		111
102 142 E		109
102 143	- 102 149	120
102 152 ERO	+ 102 152 FRO	109
102 152 HMRO		109
102 152 RO / ARO / TRO		111
102 154 ERO	+ 102 154 FRO	109
102 154 RO / ARO / TRO		111
102 155	+ 102 155 RO	111
102 158 RO		112
102 182	- 102 191	117
102 193 RO		117
102 201	- 102 207	113
102 208	- 102 215	114
102 221	- 102 227	114
102 228	- 102 232	115

Artikel-Nr.		Seite/n
102 241	- 102 247	115
102 248	- 102 252	116
102 261	- 102 268	108
102 271	- 102 278	112
102 300 E	- 102 305 E	121
102 301	- 102 305	121
102 301 T	- 102 305 T	121
102 312 RO / ERO / TRO		121
102 313	- 102 318	119
102 313 T	- 102 318 T	119
102 319 RO	+ 102 319 TRO	119
102 320		120
102 401	- 102 421	122
102 401 T	- 102 421 T	122
102 422	- 102 442	124
102 450 RO	+ 102 450 TRO	123
102 452 RO	+ 102 452 TRO	123
102 521	- 102 530	116
102 601	- 102 638	88 - 89
102 767	- 102 785	107
102 767 E	- 102 785 E	106
102 767 EP	- 102 785 EP	106
102 767 P	- 102 785 P	107
102 790 EPRO	- 102 791 EPRO	106
102 790 ERO	- 102 791 ERO	106
102 790 PRO	- 102 791 PRO	107
102 790 RO	- 102 791 RO	107
102 874	- 108 294	105
102 874 E	- 108 294 E	104
102 874 EP	- 108 294 EP	104
102 874 P	- 108 294 P	105
102 890 EPRO	- 102 891 EPRO	104
102 890 ERO	- 102 891 ERO	104
102 890 PRO	- 102 891 PRO	105
102 890 RO	- 102 891 RO	105
103 108	- 103 116	301
103 110 K	- 103 116 K	301
105 016	- 105 120	248
105 170	- 105 174	249
105 300	+ 105 635	248
106 014	- 106 200	251
106 201	- 106 211	254
106 301	- 106 306	252
106 318	+ 126 318	252
107 003	- 107 006	295
107 010	- 107 051	292 - 293
107 052	- 107 061	294
108 010 A		210
108 012	- 108 080	201
108 025 RU		212
108 040 RU		214
108 104	+ 108 105	255
108 108	- 108 126	220
108 108	+ 108 110	255
108 110		203
108 1112	- 108 1132	199
108 1133	- 108 1180	200
108 1210	- 108 1215	192
108 1510		203
108 1519	- 108 15275	202
108 160	- 108 163	219
108 166	- 108 175	219

Artikel-Nr.		Seite/n
108 2000		203
108 202		220
108 2020	- 108 2032	196
108 2020 F	- 108 2032 F	196
108 212	- 108 260	194
108 212 E	- 108 260 E	194
108 212 F	- 108 260 F	194
108 302-1	+ 108 303-1	218
108 304	- 108 306	203
108 312-1	+ 108 313-1	218
108 512	- 108 560	193
108 512 E	- 108 560 E	193
108 512 F	- 108 560 F	193
108 701		203
108 712	- 108 750	198
108 810	+ 108 810 E	195
108 811 E		197
108 820	+ 108 820 F	195
108 830		192
108 840	+ 108 840 F	195
108 912 E	- 108 960 E	197
109 001	- 109 008	299
109 002 K	- 109 008 K	299
109 004	- 109 116	300 - 301
109 101		300
109 127	- 109 635	298
109 152 K	- 109 653 K	298
113 015	- 113 100	247
113 201	+ 113 203	255
113 216	- 113 218	247
116 001	- 116 005	235
116 003 RO	- 116 003 TCRO	234
116 008	+ 116 008 TC	234
116 010	- 116 019	228
116 010 TC	- 116 019 TC	228
116 015 A	+ 116 018 A	228
116 020	- 116 024	229
116 020 A	+ 116 023 A	229
116 020 TC	- 116 024 TC	229
116 025	- 116 029	231
116 025 A	+ 116 028 A	231
116 025 TC	- 116 029 TC	231
116 030	- 116 035	230
116 030 A	+ 116 033 A	230
116 030 TC	- 116 034 TC	230
116 035	- 116 039	233
116 035 TC	- 116 039 TC	233
116 041	- 116 045	229
116 041 TC	- 116 045 TC	229
116 046	+ 116 047	228
116 048	+ 116 052	229
116 049		231
116 050		230
116 051		233
116 100	+ 116 113	240
116 100 L		236
116 100-1		240
116 101 L		240
116 103 ARO		234
116 110 L		237
116 119	+ 116 121	240
116 120 L		238

Artikel-Nr.		Seite/n
116 130 L		239
116 210	- 116 215	230
116 216	+ 116 221	231
116 227	- 116 231	232
116 232	- 116 237	232
116 233 A		232
116 235 A	- 116 236 A	232
116 238	- 116 242	233
126 014	- 126 200	250
126 201	- 126 211	254
126 301	- 126 306	252
128 012	- 128 080	246
128 211	- 128 216	246
200 105	- 200 250	49
200 4 105	- 200 4 200	49
200 4 201		49
200 5 105	- 200 5 200	49
201 003	- 201 200	46 - 47
202 020	- 202 130	55
202 020 E	- 202 130 E	54
202 020 T	- 202 130 T	55
203 025	- 203 130	50
204 100	- 204 600	52 - 53
204 100 E	- 204 300 E	52
205 208		48
205 208 L		32
205 208 L		48
205 2081 L		32
205 2081 L		48
205 212 RO	- 205 218 RO	48
205 223		48
205 246	+ 205 246 RO	311
211 035	- 211 260	310
211 050 K	- 211 141 K	311
214 003	- 214 201	38 - 40
214 010 Li	- 214 130 Li	45
214 200 RO		41
214 208		41
214 214 LiRO	- 214 215 LiRO	45
214 214 RO	- 214 218 RO	41
214 223		41
214 801	- 214 829	42
214 850 RO	- 214 851 RO	42
215 010	- 215 210	30 - 31
215 200 RO		32
215 208		32
215 214 RO	- 215 218 RO	31
215 223		32
215 801	- 215 829	33
215 850 RO	- 215 851 RO	33
217 008	- 217 063	56
223 004	- 223 012	312
223 050	- 223 120	312
226 0301	- 226 1001	313
226 200	- 226 203	313
228 010	- 228 130	34
228 214 RO	- 228 215 RO	34
230 020	- 230 520	130
230 020 E	- 230 240 E	130
230 030 Li	- 230 200 Li	132
231 010 NPT	- 231 116 NPT	143
231 030	- 231 120	141

Artikel-Nr.		Seite/n
231 030 E	- 231 120 E	141
232 020	- 232 100	160
232 020 E	- 232 100 E	160
232 020 EF	- 232 100 EF	160
232 020 T	- 232 100 T	160
232 020 VA	- 232 100 VA	160
232 030	- 272 240	167
232 031 E	- 232 300 E	162
232 031 EF	- 232300 EF	162
232 031 VA	- 232 300 VA	162
232 120	- 232 300	162
232 120 T	- 232 300 T	162
233 030 E	- 233 300 E	163
233 030 EF	- 233 300 EF	163
233 030 VA	- 233 300 VA	163
233 120	- 233 300	163
233 120 T	- 233 300 T	163
234 020	- 234 100	161
234 020 E	- 234 100 E	161
234 020 EF	- 234 100 EF	161
234 020 T	- 234 100 T	161
234 020 VA	- 234 100 VA	161
235 030	- 235 520	133
236 010	- 236 138	135
236 210	- 236 238	144
237 020	- 237 520	131
237 020 E	- 237 240 E	131
237 030 Li	- 237 200 Li	132
238 030	- 238 120	131
239 030	- 239 520	134
240 010	- 240 158	135
240 010 UNC	- 240 916 UNC	137
240 010 UNF	- 240 916 UNF	138
241 001	- 241 020	147
241 021	- 241 180	146
241 100	- 241 107	147
241 200	- 241 206	147
242 165	- 242 10522	146
243 030	- 243 240	175
244 001	- 244 087	179
244 101	- 244 110	179
244 151		179
244 183	- 244 184	182
244 200	- 244 207	184
244 208	- 244 209	183
244 303	- 244 315	182
244 403	- 244 415	182
244 503	- 244 515	182
244 603	- 244 615	185
245 001 RO	+ 245 001 ERO	139
245 002	+ 245 002 E	139
245 003	+ 245 003 RO	140
245 003 E	+ 245 003 ERO	139
245 004 RO		142
245 010	+ 245 010 E	140
245 020	+ 245 020 E	140
245 030	+ 245 030 E	139
245 030		140
245 040	+ 245 040 E	140
245 041		140
245 048 RO	- 245 052 RO	165
245 054		164

Artikel-Nr.		Seite/n
245 057 RO	- 245 069 RO	164
245 059		145
245 072	- 245 074	145
246 010	- 246 916	136
246 010 UNC	- 246 916 UNC	137
246 010 UNF	- 246 916 UNF	138
247 010	- 247 916	136
250 003 T	- 250 160 T	38 - 40
250 214 TRO	- 250 215 TRO	41
250 801 T	- 250 829 T	43
250 850 TRO	- 250 851 TRO	43
2501 010 T	- 2501 130 T	44
2501 214 TRO	- 2501 215 TRO	44
252 025	- 252 065	56
254 020	- 254 130	51
255 030	- 255 130	51
258 010 F	- 258 160 F	36
258 214 FRO	- 258 215 FRO	37
258 214 RO	- 258 215 RO	37
259 004 RO		24
259 010	- 259 130	23
259 010 E	- 259 130 E	22
259 048 RO	+ 259 048 ERO	24
259 214 ERO	- 259 215 ERO	22
259 214 RO	- 259 215 RO	23
260 041 E	- 260 302 E	169
261 041 E	- 260 302 E	170
264 007	- 264 135	175
265 010 UNC	- 265 916 UNC	171
265 010 UNF	- 265 916 UNF	173
266 010 UNC	- 266 916 UNC	172
266 010 UNF	- 266 916 UNF	174
267 030	- 267 300	143
267 610	- 267 638	144
270 013		119
270 014 P	- 270 215 P	158
270 020 RO	+ 270 020 TRO	177
270 14	- 270 019	177
270 14 T	- 270 019 T	177
270 616	- 270 619	158
270 616 P	- 270 619 P	158
270 620 RO	+ 270 620 PRO	158
271 003 F	- 271 012 F	176
273 030 ETC	- 273 240 ETC	168
281 010 E	- 281 160 E	26 - 27
281 010 EF	- 281 160 EF	26 - 27
281 214 EFRO	- 281 215 EFRO	28
281 214 ERO	- 281 215 ERO	28
3121 300 18 R	- 3121 300 32 R	284
317 000 33 R		285
3181 300 18 R	- 3181 300 32 R	284
321 8001	- 321 8072	264 - 269
321 8811	- 321 8832	272 - 273
323 8001	- 323 8072	264 - 271
331 89015	- 331 89895	274 283
R 270 014	- R 270 019	178
R 270 014 T	- R 270 019 T	178
R 270 020 RO	- R 270 021 RO	178
W 102 313	- W 102 318	118
W 102 313 T	- W 102 318 T	118

RUKO GmbH Präzisionswerkzeuge  
Robert-Bosch-Straße 7 – 11  
71088 Holzgerlingen  
Deutschland

+49 (0)7031 6800-0  
www.ruko.de | info@ruko.de



© Alle Rechte beim Herausgeber.  
Dieser Katalog ist urheberrechtlich geschützt und bleibt unser  
Eigentum. Änderungen von technischen Daten behalten wir uns  
vor. Abbildungen sind unverbindlich. Die Haftung für Druckfehler  
ist ausgeschlossen. Mit diesem Katalog werden alle vorherigen  
Ausgaben ungültig.

Nr. 810504/24 | 1. Auflage – Oktober 2024

